



Series 1300A

product guide

features

- All New Design
- 110' Four-Section Boom
- 30 Ton Rating
- Self-lubricating "Easy Glide" Wear Pads
- Internal Anti-two-block
- NEW VISION CAB™



contents

Features	2
Mounting Configurations	3
Specifications	4
Capacities: With 25'-44' Jib Full Outrigger Span	5
Capacities: With 25'-44' Jib Midspan Outrigger	6
Accessories	7



features

Why Buy a National Series 1300A

2



*Product may be shown with optional equipment.

- 30-ton (27.21-t) maximum capacity
- 163-ft (49.68-m) w/optional jib maximum vertical reach*
- 119-ft (36.27-m) maximum vertical hydraulic reach*
- Load Moment Indicator system (LMI)
- Proportional boom extension
- High performance planetary winch
- Heavy-duty triple pump hydraulics
- * Maximum vertical reach is ground-level to boom tip height at maximum extension and angle with outriggers/stabilizers fully extended.

1300A



- **30-ton Rating** – The new 1300A is a 30-ton machine and has increased capacities over the former Series 1300 model.
- **110-foot Four-section Boom** – The longest in its size range. The longer boom allows the operator to perform more lifts without the use of a jib, reducing setup time and improving efficiency. A 69-foot four-section boom or a 100-foot four-section boom is also available.
- **Overload Protection** – All National cranes are equipped with overload protection:
 - Load Moment Indicator (LMI) is standard on all series 1300A machines.
 - LMI display console is weatherproof.
 - LCD display is visible in full or low light.
 - All crane load lifting values are displayed simultaneously.
- **Self-lubricating “Easy glide” Boom Wear Pads** – The self-lubricating boom pads, standard on the 1300A, reduce the conditions that cause boom chatter and vibration. The net result is smoother crane operation.
- **“HO”-style Outriggers** – Two sets of “HO”-style outriggers with 20’ (6.09 m) span, with 14-ft. (4.27 m) mid span setting with manual locks and reduced capacity chart and fully retracted outrigger spread with reduced capacity chart. Outriggers are equipped with removable ball and socket aluminum foot pads. Independent outrigger controls (umbilical design) are located at rear of the crane and includes level indicator (sight bubble).
- **Continuous Rotation/Glide Swing** – The series 1300A is supplied with 360° continuous rotation as standard, along with the “glide swing” feature - allowing free swing during rotation - and a manually applied foot brake.
- **Adjustable Swing Speed** – Standard on the 1300A. A control knob located on the swing motor brake release valve can be easily adjusted to the crane operator’s swing speed preference.
- **Oil Cooler** – Radiator mounted on top of front outriggers with electric fan is standard.
- **Heavier Duty Torsion Box** – The stronger standard torsion box improves rigidity, reduces truck frame flex and reduces the need for turret mounted counterweight.
- **Speedy-reeve Boom Tip and Sheave Blocks** – These standard features simplify rigging changes by decreasing the time needed to change line reeving.
- **Pre-painted Components** – Painting crane components before assembly reduces the possibility of rust, improves serviceability and enhances the appearance of the machine.
- **Deluxe Operator’s Cab** – NEW VISION CAB™ has a rigid powder coated steel structure, is well insulated, with ample safety glass for operator visibility and comfort. Multi-position seat with arm rest controls, ventilation fans, diesel heater, wipers. Optional air-conditioning is available. Optional open-seat control station in lieu of enclosed cab is available.
- **Improved Serviceability** –
 - Bearings on the boom extend and retract cables can be greased through access holes in the boom side plates.
 - Number of internal boom parts has been reduced, decreasing service time when rebuilding the machine.
- **New State-of-the-art Control Valve** – Provides smoother operation. The new design eliminates parts, reducing repair costs and improving the machine’s serviceability.
- **National Crane Is the Market Leader** – National is number one in the production of commercial truck-mounted boom trucks. National has many programs and people directly and indirectly involved to provide our customers reliable products.
 - National has the boom truck industry’s leading test program. Every structural part of the crane is cycle tested up to 60,000 cycles at full capacity. In addition to cycle testing, each model is subjected to state-of-the-art strain gauge testing that measures metal deformation as small as one one-millionth of an inch. The net result is that any weak areas are caught in test, not on job sites where costly downtime occurs.
 - Lift and telescoping cylinders are manufactured by National Crane, so that the seals, packing glands, and end plates are traced for accurate shipment of replacement parts.
 - Parts are available for all National Crane machines, even if they are 35 years old.
 - National has a formalized quality program and is ISO 9001 approved.
- **You Expect National Crane to be a Quality Product That Will Provide Years of Service, and So Do We.**
- **National Crane’s Quality Management System is ISO 9001:2000 Approved.**



mounting configuration

1300A TRUCK REQUIREMENTS

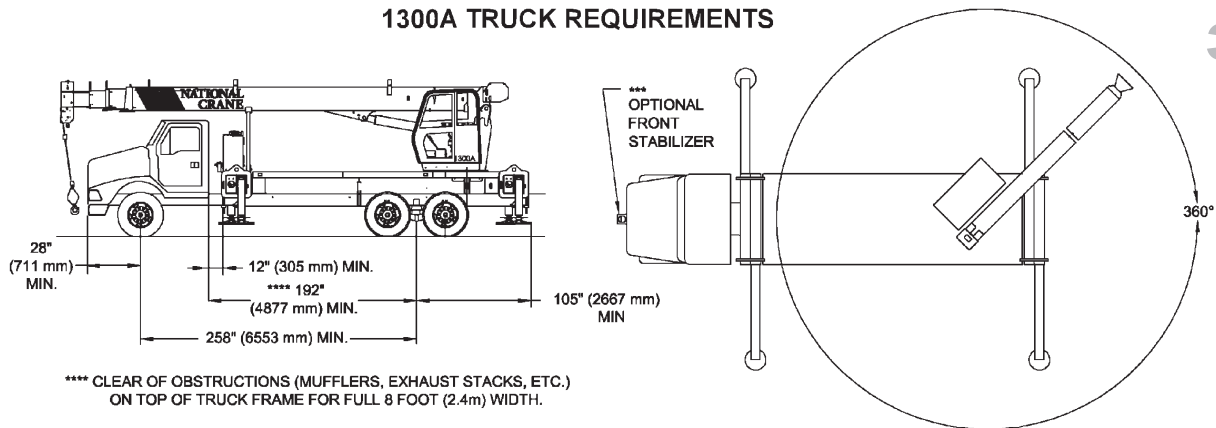

**** CLEAR OF OBSTRUCTIONS (MUFFLERS, EXHAUST STACKS, ETC.) ON TOP OF TRUCK FRAME FOR FULL 8 FOOT (2.4m) WIDTH.

The mounting configuration shown is based on an 85% stability factor. The complete unit must be installed on the truck in accordance with factory requirements, and a test performed to determine actual stability and counterweight requirements, since individual truck chassis vary. If bare truck weights are not met, counterweight will be required. A summary of mounting and truck requirements are:

Working area
360°

Gross Axle Weight Rating (GAWR),
front 18,000 lb (8165 kg)

Gross Axle Weight Rating (GAWR),
rear 34,000 lb (15 455 kg)

Gross Vehicle Weight Rating
52,000 lb (23 587 kg)

Wheelbase (WB)
258 in (6.55 m)

Cab to Axle/Trunnion (CT)
192 -in (4877mm);

After Frame (AF)
105-in (2667mm) minimum

Frame Section Modulus (SM), front axle to end of afterframe: 110,000 psi (759 MPa) 20-in3 (327-cm3) See "Truck Frame Strength" section.

Estimated bare chassis weight required for stability prior to installation of crane or accessories:
Front 9,000 lb (4082 kg)
Rear 8,500 lb (3856 kg) *
10,000 lb (4536 kg) with optional bed

Front Axle Maximum Weight**
10,500 lbs (4763 kg)

*10,000 lb (4536 kg) is required at the rear axle for 360° stability. This weight does include the weight of the optional bed. Counterweight will be required above the 8500 lb (3856 kg) minimum bare chassis if the

optional bed is not used to attain the 10,000 lb (4536 kg) stability weight.

**Weight in excess of 10,500 lb (4763 kg) will require the addition of a front stabilizer or additional rear axle stability weight for over front stability. One-half of the front axle weight in excess of the maximum at the rear axle will maintain stability.

Example: A 11,000 lb (4990 kg) Bare Front Axle will maintain stability if the rear axle bare is 8750 lb (3969 kg) and 10,250 lb (4649 kg) with the additional optional bed weight.

***A single front stabilizer is not necessary for 360° stability if mounting dimensions are maintained and minimum rear axle and maximum front axle weights are not exceeded.

NOTE 1: Gross Vehicle Weight Rating (GVWR) is dependent on all components of the vehicle (axles, tires, springs, frame, etc.) meeting manufacturers' recommendations; always specify GVWR when purchasing trucks.

NOTE 2: Diesel engines require a variable speed governor and energize-to-run fuel solenoid for smooth crane operation; electronic fuel injection is required.

NOTE 3: All mounting data is based on a National Series 1300A with subbase and an 85 percent stability factor.

NOTE 4: The complete unit must be installed in accordance with factory requirements, and a test performed to determine actual stability and counterweight requirements; contact the factory for details.

NOTE 5: Transmission neutral safety interlock switch is required.

3

1300A



specifications

Boom and Jib Combinations Data

AVAILABLE IN THREE BASIC MODELS.

4

Model 1369A — Equipped with a 22 ft to 69 ft (6.7-21.03 m) four-section boom. Maximum tip height is 78 ft (23.77 m).

22'-69' (6.7-21.05 m) four-section boom.



Model 13100A — Equipped with a 29 ft to 100 ft (8.83-30.48 m) four-section boom. This model can be equipped with a 25-44 ft (7.62-13.41 m) two section jib. Maximum tip height w/44ft (13.41 m) jib is 153 ft (44.63 m).

29'-100' (8.83-30.48 m) four-section boom.



29'-100' (8.83-30.48 m) four-section boom. **13FJ44M** 25-44 ft. (7.62-13.41 m) two-section jib



Model 13110A — Equipped with a 33 ft to 110 ft (10.05-33.52 m) four-section boom. This model can be equipped with a 25-44 ft (7.62-13.41 m) two-section jib. Maximum tip height w/44ft (13.41 m) jib is 163 ft (49.68 m).

33'-110' (10.05-33.52 m) four-section boom.



33'-110' (10.05-33.52 m) four-section boom. **13FJ44M** 25-44 ft. (7.62-13.41 m) two-section jib



Note: Maximum tip height is measured with outriggers/stabilizers fully extended.

1300 Winch Data

- Do not deadhead line block against boom tip when extending boom.
- Keep at least 3 wraps of loadline on drum at all times.
- Use only 9/16" diameter rotation-resistant cable with 38,500 pounds breaking strength on this machine.

			1 Part Line	2 Part Line	3 Part Line	4 Part Line	5 Part Line	6 Part Line	7 Part Line
MAXIMUM BOOM LENGTH AT MAXIMUM ELEVATION WITH RIGGING SHOWN			144' boom jib	100'	75'	60'	50'	43'	36'
WITH LOAD BLOCK AT GROUND LEVEL			154' boom jib	110'	94'	78'	62'	46'	32'
Winch	Average Cable Supplied	Breaking Strength	Lift and Speed	Lift and Speed	Lift and Speed	Lift and Speed	Lift and Speed	Lift and Speed	Lift and Speed
Standard Planetary Winch	9/16" Diameter Rotation Resistant	38,500 lb (17 464 kg)	7,700 lb (3493 kg) 164 fpm (50 m/min)	15,400 lb (6986 kg) 82 fpm (25 m/min)	23,100 lb (10 478 kg) 55 fpm (16 m/min)	30,800 lb (13 971 kg) 41 fpm (12 m/min)	38,500 lb (17 464 kg) 33 fpm (10 m/min)	46,200 lb (20 956 kg) 27 fpm (8 m/min)	53,900 lb (24 449 kg) 23 fpm (7 m/min)
"Burst of Speed"	9/16" Diameter Rotation Resistant	38,500 lb (17 464 kg)	3,000 lb (1361 kg) 365 fpm (111 m/min)	6,000 lb (2722 kg) 132 fpm (40 m/min)	9,000 lb (4083 kg) 88 fpm (27 m/min)	12,000 lb (5443 kg) 66 fpm (20 m/min)	15,000 lb (6804 kg) 53 fpm (16 m/min)	18,000 lb (8 165 kg) 44 fpm (13 m/min)	21,000 lb (9 526 kg) 38 fpm (11 m/min)

All winch pulls and speeds in this chart are shown on the fourth layer. Winch line pulls would increase on the first, second and third layers. Winch line speed would decrease on the first, second and third layers. Winch line pulls may be limited by the winch capacity or the ANSI 5 to 1 cable safety factor. These are shown below:

Winch	4th Layer Drum Pull	Allowable Cable Pull
Standard planetary	7,700 lb. (3493 kg) (low speed) 3,000 lb. (1361 kg) ("burst of speed")	7,700 lb. (3492 kg)

Block Type	Rating	Weight
Downhaul Weight	5 Ton (4.53t)	150 lb (68 kg)
1 Sheave Block	12 Ton	305 lb (139 kg)
2 Sheave Block	19 Ton	350 lb (159 kg)
3 Sheave Block	30 Ton	575 lb (261 kg)

1300A



capacities

Load Rating Chart: Series 13110A with 25'-44' Jib / Fullspan Outrigger 20'

Other Series 1300A Load Rating Charts are available. National will send you a chart on request – or you may secure needed load rating information through your nearest National dealer.

7

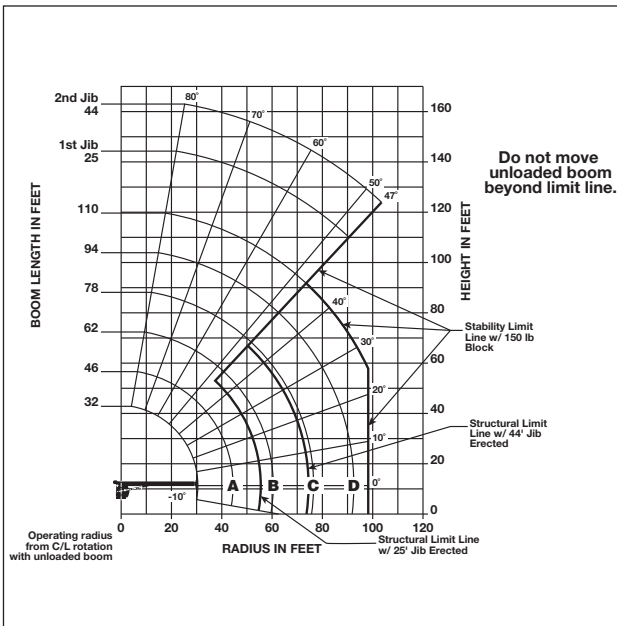

CAUTION:

- Do not operate crane booms, jib extensions, any accessories or loads within 10 ft (3m) of live power lines or other conductors of electricity.
- Jib and boom capacities shown are maximum for each section.
- Do not exceed capacities at reduced radii.
- Load ratings shown on the appropriate charts are maximum allowable loads with the crane mounted on a factory-approved truck and all outriggers at either full span or at mid span range and set on a firm level surface so that the crane is level and all tires are suspended.
- Always level the crane with the level indicator located on the crane.
- The operator must reduce load to allow for factors such as wind, ground conditions, operating speeds and their effects on freely suspended loads.
- Overloading this crane may cause structural collapse or instability.
- Weights on any accessories attached to the boom or loadline must be deducted from the load chart capacities.
- Do not exceed jib capabilities at any reduced boom lengths.
- Do not deadhead lineblock against boom tip when extending boom or winching up.
- Keep at least three wraps of loadline on drum at all times.
- Use only specified cable with this machine.

**SERIES 13110A
WITH
25'-44' JIB
FULL SPAN
OUTRIGGER 20'**

NOTE:

1. Operate with jib by radius when main boom is fully extended. If necessary increase boom angle to maintain loaded radius.
2. Operate with jib by boom angle when main boom is not fully extended. Do not exceed rated jib capacities at any reduced boom lengths.

LOADLINE EQUIPMENT DEDUCT (lb.)

Downhaul weight.....	150
One sheave block.....	305
Two sheave block.....	350
Three sheave block.....	575

Load Rating: Series 13110A with 25'-44' Jib / Fullspan Outrigger 20'

32 ft - 110 ft BOOM RATED LOADS WITHOUT JIB

LOADED RADIUS (ft)	LOADED BOOM ANGLE (deg)	32 ft BOOM (ft)	LOADED BOOM ANGLE (deg)	A 46 ft BOOM (ft)	LOADED BOOM ANGLE (deg)	B 62 ft BOOM (ft)	LOADED BOOM ANGLE (deg)	C 78 ft BOOM (ft)	LOADED BOOM ANGLE (deg)	D 94 ft BOOM (ft)	LOADED BOOM ANGLE (deg)	110 ft BOOM (ft)		
5	78.5	*60,000												
8	74.5	43,000												
10	70.5	35,900	77.5	29,100										
12	66.5	30,900	75	28,900										
15	60	25,500	71	24,000	77	23,000								
20	48.5	19,450	63.5	18,450	72	17,550	77	17,000						
25	34	14,900	56	14,800	67	14,100	73	13,600	77.5	13,300				
30			48	12,150	61.5	11,650	69	11,200	74	10,950	77	7,950		
35			38.5	9,600	56	9,850	64.5	9,450	70.5	9,200	74	6,300		
40			27	7,600	49.5	7,950	60.5	8,100	67	7,850	71.5	5,950		
45					43.5	6,350	56	6,600	64	6,800	69	5,700		
50					36	5,100	51.5	5,350	60	5,550	66	5,400		
55					26	4,050	46	4,300	56	4,550	63	4,750		
60						8.5	2,650	40	3,500	52	3,700	59.5	3,900	
65								33.5	2,850	48	3,000	56	3,200	
70								25.5	2,250	43	2,450	52.5	2,600	
75									13	1,750	38	1,950	49	2,100
80										32	1,500	45	1,650	
85										25	1,100	41	1,250	
90										15	750	36	900	
95												31	600	
100														
0		6,300	0	3,250	0	1,450	0							

25 - 44 ft JIB RATED LOADS

LOADED RADIUS (ft)	LOADED BOOM ANGLE (deg)	25 ft JIB (ft)	LOADED BOOM ANGLE (deg)	44 ft JIB (ft)
35	76.5	4,200		
40	75	4,100	76.5	2,500
45	73	4,000	75.5	2,500
50	71	3,850	74	2,500
55	69	3,600	72.5	2,500
60	66.5	3,300	70.5	2,350
65	64	3,050	68.5	2,250
70	61.5	2,500	66.5	2,150
75	59	2,000	64.5	2,050
80	56	1,550	62	1,900
85	53.5	1,100	60	1,800
90	50.5	700	57	1,400
95			54.5	1,050
100			51.5	650
105				

*SHADED AREAS ARE STRUCTURALLY LIMITED CAPACITIES

THIS CHART IS ONLY A GUIDE AND SHOULD NOT BE USED TO OPERATE THE CRANE. The individual crane's load chart, operating instructions and other instructional plates must be read and understood prior to operating the crane.

1300A



capacities

Load Rating Chart: Series 13110A with 25'-44' Jib / Midspan Outrigger 14'

Other Series 1300A Load Rating Charts are available. National will send you a chart on request – or you may secure needed load rating information through your nearest National dealer.

8

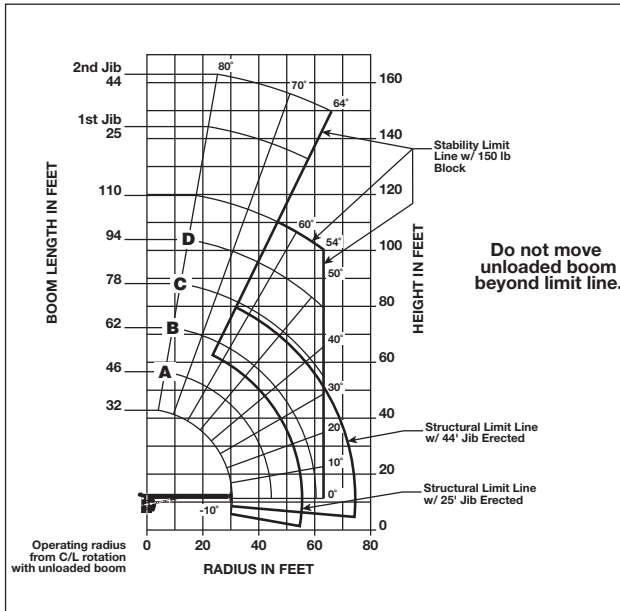

CAUTION:

- Do not operate crane booms, jib extensions, any accessories or loads within 10 ft (3m) of live power lines or other conductors of electricity.
- Jib and boom capacities shown are maximum for each section.
- Do not exceed capacities at reduced radii.
- Load ratings shown on the load rating charts are maximum allowable loads with the outriggers properly extended and the outrigger lock pins engaged on a firm, level surface and the crane leveled and mounted on a factory recommended truck.
- Always level the crane with the level indicator located on the crane.
- The operator must reduce load to allow for factors such as wind, ground conditions, operating speeds and their effects on freely suspended loads.
- Overloading this crane may cause structural collapse or instability.
- Weights on any accessories attached to the boom or loadline must be deducted from the load chart capacities.
- Do not exceed jib capabilities at any reduced boom lengths.
- Do not deadhead lineblock against boom tip when extending boom or winching up.
- Keep at least three wraps of loadline on drum at all times.
- Use only specified cable with this machine.

**SERIES 13110A
WITH
25'-44' JIB
MIDSPAN
OUTRIGGER 14'**

LOADLINE EQUIPMENT DEDUCT (lb.)

Downhaul weight.....	150
One sheave block.....	305
Two sheave block.....	350
Three sheave block.....	575

Load Rating Chart: Series 13110A with 25'-44' Jib / Midspan Outrigger 14'

32 ft – 110 ft BOOM RATED LOADS WITHOUT JIB

LOADED RADIUS (ft)	LOADED BOOM ANGLE (deg)	32 ft BOOM (ft)	LOADED BOOM ANGLE (deg)	A 46 ft BOOM (ft)	LOADED BOOM ANGLE (deg)	B 62 ft BOOM (ft)	LOADED BOOM ANGLE (deg)	C 78 ft BOOM (ft)	LOADED BOOM ANGLE (deg)	D 94 ft BOOM (ft)	LOADED BOOM ANGLE (deg)	110 ft BOOM (ft)
5	78.5	60,000										
8	74.5	43,000										
10	70.5	35,900	77.5	34,100								
12	66.5	30,900	75	29,200								
15	60	24,300	71	24,000	77	20,000						
20	48.5	13,300	63.5	13,950	72	14,400	76.5	14,900				
25	34	8,350	56	8,900	66.5	9,600	72	9,600	76.5	10,000		
30			48	6,150	61.5	6,500	68.5	6,750	73	6,900	76.5	7,250
35			38.5	4,300	55.5	4,650	64	4,850	69.5	5,050	73.5	5,350
40			26.5	3,050	49.5	3,350	59.5	3,550	66	3,700	70.5	3,900
45					43	2,350	55	2,550	62.5	2,700	67	2,850
50					35	1,650	50	1,800	58.5	1,950	64	2,050
55					25	1,000	45	1,200	55	1,350	61	1,450
60					8	550	39	750	50.5	850	58	950
65											54.5	500
70												
	0	5,300	0	2,100	0	500						

25 – 44 ft JIB RATED LOADS

LOADED RADIUS (ft)	LOADED BOOM ANGLE (deg)	25 ft JIB (ft)	LOADED BOOM ANGLE (deg)	44 ft JIB (ft)
35	76.5	4,200		
40	75	4,100	76.5	2,500
45	73	2,650	75.5	2,500
50	71	1,800	74	2,500
55	69	1,200	72.5	2,000
60	66.5	700	70.5	1,400
65			68.5	950
70				

*SHADED AREAS ARE STRUCTURALLY LIMITED CAPACITIES

THIS CHART IS ONLY A GUIDE AND SHOULD NOT BE USED TO OPERATE THE CRANE. The individual crane's load chart, operating instructions and other instructional plates must be read and understood prior to operating the crane.

1300A



accessories

9

Radio Remote Controls –

Eliminate the handling and maintenance concerns that accompany cabled remotes. Operate to a range of about 250 feet (76 m), varying with conditions.

- **Model NB4R**

One-Person Basket –

Strong but lightweight steel basket with 300-lb. (139-kg) capacity, gravity hung with swing lock and full body harness.

- **Model B1-S**
- **Model 2B1-S** (for dual locking baskets)

Heavy-duty Personnel Basket –

1,200-lb. (544-kg) capacity steel basket with safety loops for four passengers. Gravity leveling 72- x 42-inch (183- x 107-cm) platform. Fast attachment and secure locking systems. Load chart must show 2,300 lb. (1043 kg) minimum to operate this accessory.

- **Model BSA-1**
- **Model BSA-R1** (provides rotation)

Air Conditioning –

Back of cab mounted - self contained modular unit with in cab cool air outlets. Requires 130+ amp. chassis alternator.

- **Model AC**

Winch Drum Rotation Indicator

- **Model WDRI**

Last Wrap Indicator Option on winch with indicator in cab.

- **Model LLI**

Outrigger Controls at operator's seat in addition to ground controls

- **Model ICORC**

Dimensions Specifications

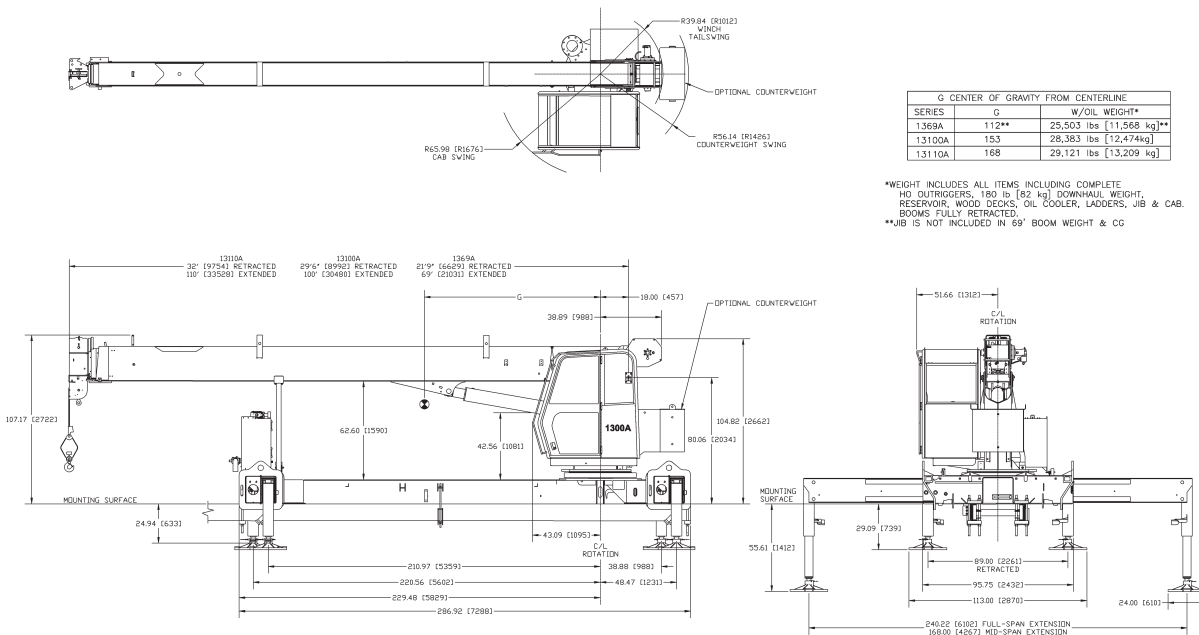

1300A



notes

10

1300A



notes**11****1300A**

NATIONAL CRANE

Manitowoc Crane Group - Americas

Manitowoc, Wisconsin Facility
 Tel: [Int + 001] 920 684 6621
 Fax: [Int + 001] 920 683 6277
 Shady Grove, Pennsylvania Facility
 Tel: [Int + 001] 717 597 8121
 Fax: [Int + 001] 717 597 4062

Manitowoc Crane Group - EMEA

Europe Middle East & Africa
 Tel: [Int + 33] (0) 191 565 6281
 Fax: [Int + 33] (0) 4 72 18 20 20

Manitowoc Crane Group - UK

Europe Middle East & Africa
 Tel: [Int + 44] (0) 191 565 6281
 Fax: [Int + 44] (0) 191 564 0442

Manitowoc Crane Group - Germany

(Sales, Parts & Service)
 Tel: [Int + 49](0) 2173 8909 0
 Fax: [Int + 49] (0) 2173 8909-30

Manitowoc Crane Group - France

France & Africa (Sales, Parts & Service)
 Tel: [Int + 33] (0) 1 303 13150
 Fax: [Int + 33] (0) 1 303 86085

Manitowoc Crane Group - Netherlands

(Sales, Parts & Service)
 Tel: [Int + 31] (0) 76 578 39 99
 Fax: [Int + 31] (0) 76 578 39 78

Manitowoc Crane Group - Italy

Italy & Southern Europe (Sales, Parts & Service)
 Tel: [Int + 39] (0) 331 49 33 11
 Fax: [Int + 39] (0) 331 49 33 30

Manitowoc Crane Group - Portugal

Portugal & Spain (Sales, Parts & Service)
 Tel: [Int + 351] (0) 22 968 08 89
 Fax: [Int + 351] (0) 22 968 08 97

Manitowoc Crane Group - Singapore

Asia/Pacific excl China (Sales, Parts & Service)
 Tel: [Int + 65] 6861 1733
 Fax: [Int + 65] 6862 4040 / 4142

Manitowoc Crane Group - Shanghai

China (Sales, Parts & Service)
 Tel: [Int + 86] (0) 21 64955555
 Fax: [Int + 86] (0) 2164852038

Manitowoc Crane Group - Beijing

China (Sales, Parts & Service)
 Tel: [Int + 86] (0) 10 646 71690
 Fax: [Int + 86] (0) 10 646 71691

Manitowoc Crane Group - Middle East

Sales
 Tel: [Int + 971] (0) 4 348 4478
 Fax: [Int + 971] (0) 4 348 4478
 (Parts & Service)
 Tel: [Int + 973] (0) 9 660 899
 Fax: [Int + 973] (0) 2 707 740

Distributed By:



www.manitowoccrane.com



Constant improvement and engineering progress make it necessary that we reserve the right to make specification, equipment, and price changes without notice. Illustrations/photos shown may include optional equipment and accessories, and may not include all standard equipment.

Printed in USA Form No. 1300A/0406/3M

