



Series 1400A

product guide

features

- 127' (38.72 m) Five-Section Boom
- 33 Ton (29.9 mt) Rating
- Self-lubricating "Easy Glide" Wear Pads
- Internal Anti-two-block
- NEW VISION CAB™

contents

Features	2
Mounting Configurations	3
Specifications	4
Capacities	5
Accessories	11
Dimensions Specifications	12



*Product may be shown with optional equipment.
Above product shown with optional triaxle.



features

Why Buy a National Series 1400A?

2



*Product may be shown with optional equipment.

- 33-ton (29.9-mt) maximum capacity
- 171-ft (52.12-m) maximum vertical reach*
- 135-ft (41.15-m) maximum vertical hydraulic reach*
- Load Moment Indicator system (LMI) with WADS (CANBUS system)
- Proportional boom extension
- High performance planetary winch
- 99-gallon (375L) hydraulic reservoir with 10 micron return filter.
- * Maximum vertical reach is ground-level to boom tip height at maximum extension and angle with outriggers/stabilizers fully extended.
- **33 Ton (29.9 mt) Rating** – The new 1400A is a 33-ton machine, a 10% increase in capacity over the Series 1300.
- **127-foot (38.72 m) Five-Section Boom** – The longest in its size range. The longer boom allows the operator to perform more lifts without the use of a jib, reducing setup time and improving efficiency. A 100-foot (30.5 m) four-section boom or a 110-foot (33.5 m) four-section boom is also available.
- **Overload Protection** – All National cranes are equipped with overload protection:
 - Load Moment Indicator (LMI) standard on all series 1400A machines.
 - LMI display console with WADS (Working Area Definition System) is weatherproof.
 - LCD display is visible in full or low light.
 - All crane load lifting values are displayed simultaneously.
- **Self-lubricating “Easy Glide” Boom Wear Pads** – The self-lubricating boom pads, standard on the 1400A, reduce the conditions that cause boom chatter and vibration. The net result is smoother crane operation.
- **Internal Anti-two-block Wire** – This exclusive design, standard on the Series 1400A, routes the wiring through the inside of the boom. No more snagging the wire on obstructions.
- **“H”-style Outriggers** – Two sets of “H”-style outriggers with 24’ 6” (7.47 m) span, with removable ball and socket aluminum foot pads. Independent controls located on each side of the crane - can be positioned at mid-span setting of 17’ (5.18 m). **Single-front stabilizer (SFO) with first-up feature.**
- **Continuous Rotation/Glide Swing** – The series 1400A is supplied with continuous rotation standard, along with the “glide swing” feature - allowing free swing during rotation - and a manually applied foot brake.
- **Adjustable Swing Speed** – Standard on the 1400A. A control knob located on the swing motor brake release valve can be easily adjusted to the crane operator’s swing speed preference.
- **Oil Cooler** – Radiator mounted at boom rest with electric fan is standard.
- **Heavier-duty Torsion Box** – The stronger standard torsion box improves rigidity, reduces truck frame flex and reduces the need for counterweight.
- **Electronic versions of manuals available through Manitowoc Crane CARE.**
- **Speedy-reeve Boom Tip and Sheave Blocks** – These standard features simplify rigging changes by decreasing the time needed to change line reeving.
- **Pre-painted Components** – Painting crane components before assembly reduces the possibility of rust, improves serviceability and enhances the appearance of the machine.
- **Deluxe Operator’s Cab** – NEW VISION CAB™ has a rigid powder coated steel structure, is well insulated, with ample safety glass for operator visibility and comfort. Multi-position seat with arm rest single axis joystick controls, ventilation fans, diesel heater, wipers. Optional air-conditioning is available. Optional open-seat control station in lieu of enclosed cab is available.
- **Improved Serviceability** –
 - Bearings on the boom extend and retract cables can be greased through access holes in the boom side plates.
 - Number of internal boom parts has been reduced, decreasing service time when rebuilding the machine.
- **Hydraulic System** – Pressure-compensated control valves with load-sensing variable displacement piston pump.
- **National Crane Is the Market Leader** – National is number one in the production of commercial truck-mounted boom trucks, with more than 35,000 units sold. National has many programs and people directly and indirectly involved to provide our customers with reliable products.
 - National has the boom truck industry’s leading test program. Every structural part of the crane is cycle tested up to 60,000 cycles at full capacity. In addition to cycle testing, each model is subjected to state-of-the-art strain gauge testing that measures metal deformation as small as one one-millionth of an inch. The net result is that any weak areas are caught in test, not on job sites where costly downtime occurs.
 - Parts are available for all National Crane machines, for the life of the crane.
 - National has a formalized quality program and is ISO 9001 approved.
- **You Expect National Crane to be a Quality Product That Will Provide Years of Service, and So Do We.**
- **National Crane’s Quality Management System is ISO 9001:2000 Approved.**

1400A



mounting configuration

3

The mounting configuration shown is based on the Series 1400A with an 85% stability factor. The complete unit must be installed in accordance with factory requirements and a test performed to determine actual stability and counterweight requirements since individual truck chassis vary. If bare truck weights are not met, counterweight will be required. The front bumper stabilizer (SFO) is required for all installations. Chassis must be equipped with a front frame extension suitable for SFO addition. Contact factory for complete chassis specifications.

Working area	360°
Gross Axle Weight Rating Front.....	20,000 lb (9072 kg)*
Gross Axle Weight Rating Rear.....	34,000 lb (15 422 kg)*
Gross Vehicle Weight Rating.....	54,000 lb (24 494 kg)*
Wheelbase	Minimum 258 in (655 cm)
Cab to Axle/trunnion (CA/CT)	Minimum 180 in (457 cm)
After Frame (AF)	92 in (234 cm) minimum
Frame Section Modulus (SM), front axle to end of afterframe, w/110,000 PSI (758 MPa)	30 in ³ (492 cm ³)
Stability Weight, Front.....	9,000 lb (4082 kg) minimum**
Stability Weight, Rear.....	8,000 lb (3629 kg) minimum**
Estimated Average Final Weight	51,880 lb (23 585 kg)***

The diagram shows the 360° working area that can be achieved with the front stabilizer (standard on the Series 1400A). The front stabilizer is required when extending the boom and lifting loads forward of the outriggers. A minimum of 10-in³ (164 cm³) section modulus at 110,000 psi (759 MPa) is required from the rear of the front spring hanger forward to the front stabilizer. Integral front frame extension required.

* Required to mount basic crane with 30-ft (9.15-m) jib option. Additional options or heavier bare chassis weights will require additional axles or a GVWR in excess of 54,000 lb (24 494 kg); in some states, special permits for overload are required.

** Estimated axle scale weights prior to installation of crane, stabilizers and subbase for 85% stability.

*** Includes basic crane without jib, 100-gal (379-L) fuel tank and two workers (300 lb, 136kg) in cab.

Note: Chassis will require integral extended front frame rails for SFO addition.

TRUCK REQUIREMENTS

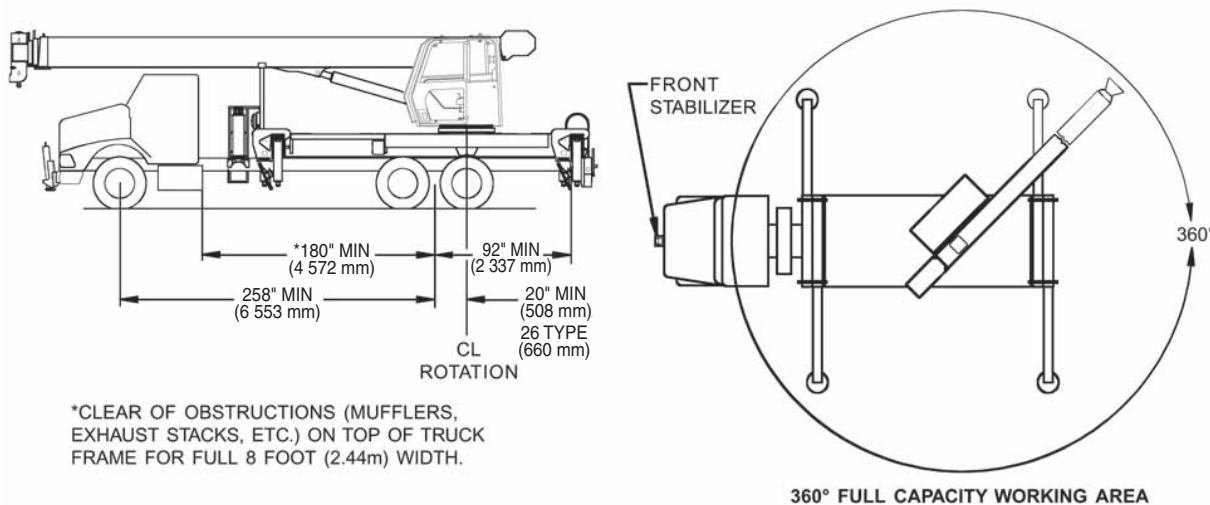

Notes:

- Gross Vehicle Weight Rating (GVWR) is dependent on all components of the vehicle (axles, tires, springs, frame, etc.) meeting manufacturers' recommendations; always specify GVWR when purchasing trucks.
- Diesel engines require a variable speed governor and energize-to-run fuel solenoid for smooth crane operation. Electronic fuel-injected engines are required.

- All mounting data is based on a National Series 1400A with the standard subbase and an 85 percent stability factor.
- The complete unit must be installed in accordance with factory requirements, and a test performed to determine actual stability and counterweight requirements per SAE J765; contact the factory for details.
- Transmission neutral safety interlock switch is required.

1400A



specifications

Boom and Jib Combinations Data

Available in three basic models.

4

Model 14100A — Equipped with a 30 ft 10 in to 100 ft (9.40-30.49 m) four-section boom. This model can be equipped with a 30 ft (9.15 m) single-section jib or a 30-54 ft (9.15-16.46 m) two-section jib. Maximum tip height w/30ft (9.15 m) jib is 137 ft (41.77 m), while maximum tip height w/30-54 ft (9.15-16.46 m) jib is 161 ft (49.08 m).

30'10" - 100' (9.40-30.49 m) four-section boom **14FJ30M** 30 ft (9.15 m) single-section jib



30'10" - 100' (9.40-30.49 m) four-section boom **14FJ54M** 30-54 ft (9.15-16.46 m) two-section jib



Model 14110A — Equipped with a 33 ft 4 in to 110 ft (10.16-33.53 m) four-section boom. This model can be equipped with a 30 ft (9.15 m) single section jib or a 30-54 ft (9.15-16.46 m) two-section jib. Maximum tip height w/30ft (9.15 m) jib is 147 ft (44.82 m), while maximum tip height w/54 ft (16.46 m) jib is 171 ft (52.13 m).

33'4" - 110' (10.16-33.53 m) four-section boom **14FJ30M** 30 ft (9.15 m) single-section jib



33'4" - 110' (10.16-33.53 m) four-section boom **14FJ54M** 30-54 ft (9.15-16.46 m) two-section jib



Model 14127A — Equipped with a 31 ft 7 in to 127 ft (9.63-38.72 m) five-section boom. This model can be equipped with a 30 ft (9.15 m) single-section jib. Maximum tip height w/ 30 ft (9.15 m) jib is 164 ft (50.00 m).









31'7" - 127' (9.63-38.72 m) five-section boom **14FJ30M** 30 ft (9.15 m) single-section jib



Note: maximum tip height is measured with outriggers/stabilizers fully extended.

1400A Winch Data

- Do not deadhead line block against boom tip when extending boom.
- Keep at least 3 wraps of loadline on drum at all times.
- Use only 5/8" diameter rotation-resistant cable with 45,400 pounds breaking strength on this machine.

			1 Part Line	2 Part Line	3 Part Line	4 Part Line	5 Part Line	6 Part Line	7 Part Line	8 Part Line
										
MAXIMUM BOOM LENGTH AT MAXIMUM ELEVATION WITH RIGGING SHOWN WITH LOAD BLOCK AT GROUND LEVEL			110' boom w/ 54' jib	110'	83'	64'	52'	43'	36'	31'
Winch	Cable Supplied	Average Breaking Strength	Lift and Speed	Lift and Speed	Lift and Speed	Lift and Speed	Lift and Speed	Lift and Speed	Lift and Speed	Lift and Speed
Standard Planetary Winch Low Speed	5/8" Diameter Rotation Resistant	45,400 lb (20 593 kg)	9,000 lb (4082 kg) 170 fpm (52 m/min)	18,000 lb (8165 kg) 85 fpm (26 m/min)	27,000 lb (12 247 kg) 57 fpm (17 m/min)	36,000 lb (16 329 kg) 43 fpm (13 m/min)	45,000 lb (20 412 kg) 34 fpm (10 m/min)	54,000 lb (24 494 kg) 28 fpm (9 m/min)	63,000 lb (28 576 kg) 24 fpm (7 m/min)	66,000 lb (29 937 kg) 21 fpm (6 m/min)
Standard Planetary Winch High Speed	5/8" Diameter Rotation Resistant	45,400 lb (20 593 kg)	4,400 lb (1996 kg) 340 fpm (104 m/min)	8,800 lb (3992 kg) 170 fpm (52 m/min)	13,200 lb (5987 kg) 113 fpm (34 m/min)	17,600 lb (7983 kg) 85 fpm (26 m/min)	22,000 lb (9979 kg) 68 fpm (21 m/min)	26,400 lb (11 975 kg) 57 fpm (17 m/min)	30,800 lb (13 971 kg) 49 fpm (15 m/min)	35,200 lb (15 967 kg) 43 fpm (13 m/min)

All winch pulls and speeds in this chart are shown on the fourth layer. Winch line pulls would increase on the first, second and third layers. Winch line speed would decrease on the first, second and third layers. Winch line pulls may be limited by the winch capacity or the ANSI 5 to 1 cable safety factor. These are shown below:

Winch	Full Drum Pull	Allowable Cable Pull
Standard planetary	4,400 lb. (1996 kg) (high speed) 9,000 lb. (4082 kg) (low speed)	9,080 lb. (4119 kg)

Block Type	Rating	Weight
Aux. Boom Head		100 lb (45 kg)
Downhaul Weight	5 Ton (4.53t)	180 lb (82 kg)
1 Sheave Block	15 Ton (13.60t)	375 lb (170 kg)
2 Sheave Block	25 Ton (22.67t)	640 lb (290 kg)
3 Sheave Block	35 Ton (31.74t)	870 lb (395 kg)
4 Sheave Block	36 Ton (32.65t)	970 lb (440 kg)

1400A



capacities

Load Rating Chart: Series 14100A (30.5 m) Boom with 30' (9.1 m) Jib / Full-Span Outrigger 24'6" (7.5 m)

Other Series 1400A Load Rating Charts are available. National will send you a chart on request – or you may secure needed load rating information through your nearest National dealer.

5

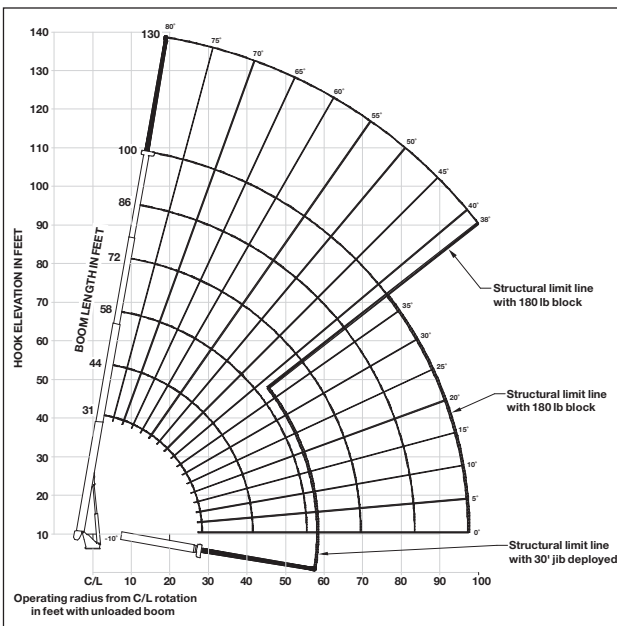

CAUTION:

- Do not operate crane booms, jib extensions, any accessories or loads within 10 ft (3m) of live power lines or other conductors of electricity.
- Jib and boom capacities shown are maximum for each section.
- Do not exceed capacities at reduced radii.
- Load ratings shown on the appropriate charts are maximum allowable loads with the crane mounted on a factory-approved truck and all outriggers at either full span or at mid span range and set on a firm level surface so that the crane is level and all tires are suspended.
- Always level the crane with the level indicator located on the crane.
- The operator must reduce load to allow for factors such as wind, ground conditions, operating speeds and their effects on freely suspended loads.
- Overloading this crane may cause structural collapse or instability.
- Weights on any accessories attached to the boom or loadline must be deducted from the load chart capacities.
- Do not exceed jib capabilities at any reduced boom lengths.
- Do not deadhead lineblock against boom tip when extending boom or winching up.
- Keep at least three wraps of loadline on drum at all times.
- Use only specified cable with this machine.

**SERIES 14100A
WITH
30' JIB /
FULL-SPAN
OUTRIGGER 24'6"**

NOTE:

1. Operate with jib by radius when main boom is fully extended. If necessary increase boom angle to maintain loaded radius.
2. Operate with jib by boom angle when main boom is not fully extended. Do not exceed rated jib capacities at any reduced boom lengths.

**LOADLINE EQUIPMENT
DEDUCT**

- Downhaul weight.....180 lb (81.6 kg)
- One sheave block375 lb (170 kg)
- Two sheave block.....640 lb (290 kg)
- Three sheave block.....870 lb (395 kg)
- Four sheave block.....970 lb (440 kg)

Load Rating Chart: Series 14100A (30.5 m) Boom with 30' (9.1 m) Jib / Full-Span Outrigger 24'6" (7.5 m)

31 TO 100 FOOT BOOM RATED LOADS WITHOUT JIB

LOADED RADIUS (ft)	LOADED BOOM ANGLE	31 ft BOOM (lb)	LOADED BOOM ANGLE	A 44 ft BOOM (lb)	LOADED BOOM ANGLE	B 58 ft BOOM (lb)	LOADED BOOM ANGLE	C 72 ft BOOM (lb)	LOADED BOOM ANGLE	D 86 ft BOOM (lb)	LOADED BOOM ANGLE	100 ft BOOM (lb)	
6	75.5	66,000											
8	71.2	52,500											
10	66.9	43,000	75	38,500									
12	62.5	39,400	72.3	34,000	77.5	28,000							
15	55.4	33,000	68	28,600	74.4	25,600	78	23,000					
20	42	24,350	60.3	22,000	69	19,700	73.8	18,400	77	17,100	78.9	11,800	
25	23.3	17,500	52.5	18,000	63.4	16,500	69.7	15,000	73.4	14,000	76.1	11,200	
30			43.5	15,300	57.6	14,000	65.1	12,700	69.7	11,750	73.3	10,800	
35			32.6	12,800	51	12,500	60.3	10,900	66.2	10,200	70.2	9,400	
40			15	10,000	44.3	10,750	55.5	9,650	62.8	9,200	67.2	8,300	
45						37	8,800	50.8	8,100	58.8	7,600	64.2	7,300
50						27.1	7,000	45.2	7,200	50.3	6,500	60.8	6,300
55						10.1	5,600	39	6,000	54.4	5,900	57.3	5,200
60								31.4	4,800	45.5	5,000	53.6	4,500
65									22.2	4,000	40.2	4,000	4,000
70										34.3	3,400	45.9	3,300
75										27.6	2,700	41.5	2,800
80										18.1	2,200	36.7	2,300
85												31.1	1,700
90												24.4	1,300
95												15	1,000
	0	12,200	0	8,000	0	4,800	0	2,200	0	1,200	0	500	

30 FOOT JIB RATED LOADS

BOOM AIS ft	BOOM ANGLE	JIB lb
30	8	500
35	8	650
40	8	800
45	2	500
50	86	800
55	84	850
60	5	950
65	85	800
70	8	800
75	84	300
80	86	800
85	87	250
90	88	700
95	85	300
00	8	000
50	82	700

*SHADED AREAS ARE STRUCTURALLY LIMITED CAPACITIES

THIS CHART IS ONLY A GUIDE AND SHOULD NOT BE USED TO OPERATE THE CRANE. The individual crane's load chart, operating instructions and other instructional plates must be read and understood prior to operating the crane.

1400A



capacities

Load Rating Chart: Series 14100A (30.5 m) Boom with 30' (9.1 m) Jib / Mid-Span Outrigger 17' (5.2 m)

6

Other Series 1400A Load Rating Charts are available. National will send you a chart on request – or you may secure needed load rating information through your nearest National dealer.

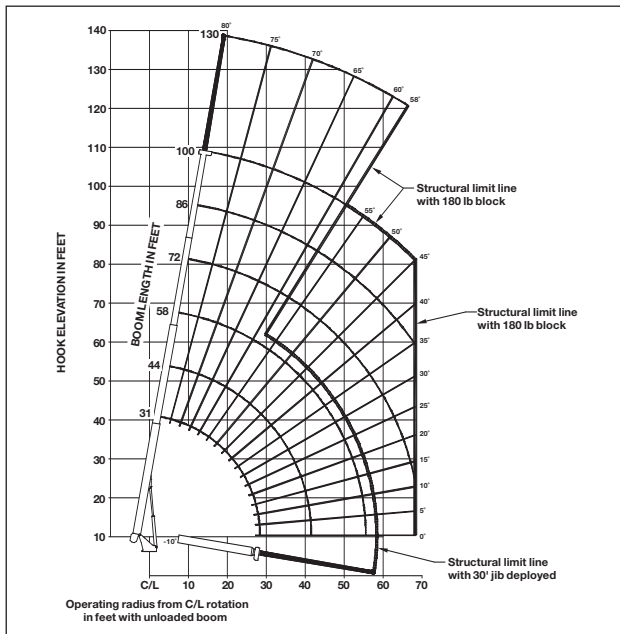

CAUTION:

- Do not operate crane booms, jib extensions, any accessories or loads within 10 ft (3m) of live power lines or other conductors of electricity.
- Jib and boom capacities shown are maximum for each section.
- Do not exceed capacities at reduced radii.
- Load ratings shown on the load rating charts are maximum allowable loads with the outriggers properly extended and the outrigger lock pins engaged on a firm, level surface and the crane leveled and mounted on a factory recommended truck.
- Always level the crane with the level indicator located on the crane.
- The operator must reduce load to allow for factors such as wind, ground conditions, operating speeds and their effects on freely suspended loads.
- Overloading this crane may cause structural collapse or instability.
- Weights on any accessories attached to the boom or loadline must be deducted from the load chart capacities.
- Do not exceed jib capabilities at any reduced boom lengths.
- Do not deadhead lineblock against boom tip when extending boom or winching up.
- Keep at least three wraps of loadline on drum at all times.
- Use only specified cable with this machine.

**SERIES 14100A
WITH
30' JIB /
MID-SPAN
OUTRIGGER 17'**

**LOADLINE EQUIPMENT
DEDUCT**

- Downhaul weight.....180 lb (81.6 kg)
- One sheave block375 lb (170 kg)
- Two sheave block.....640 lb (290 kg)
- Three sheave block.....870 lb (395 kg)
- Four sheave block.....970 lb (440 kg)

NOTE:

1. Operate with jib by radius when main boom is fully extended. If necessary increase boom angle to maintain loaded radius.
2. Operate with jib by boom angle when main boom is not fully extended. Do not exceed rated jib capacities at any reduced boom lengths.

Load Rating Chart: Series 14100A (30.5 m) Boom with 30' (9.1 m) Jib / Mid-Span Outrigger 17' (5.2 m)

31 TO 100 FOOT BOOM RATED LOADS WITHOUT JIB

LOAD RADIUS (ft)	LOADED BOOM ANGLE	31 ft BOOM (lb)	LOADED BOOM ANGLE	A 44 ft BOOM (lb)	LOADED BOOM ANGLE	B 58 ft BOOM (lb)	LOADED BOOM ANGLE	C 72 ft BOOM (lb)	LOADED BOOM ANGLE	D 86 ft BOOM (lb)	LOADED BOOM ANGLE	100 ft BOOM (lb)
6	75.5	66,000										
8	71.2	52,500										
10	66.9	43,000	75	38,500								
12	62.5	39,400	72.3	34,000	77.5	28,000						
15	55.4	33,000	68	28,600	74.4	25,600	78	23,000				
20	41.9	18,700	60.3	22,000	69	19,700	73.8	18,400	77	17,100	78.9	11,850
25	23.3	11,500	52.4	14,200	63.2	12,800	69.4	13,200	73.7	13,300	76.1	11,200
30			43.2	9,800	57.7	8,800	65.2	9,100	69.8	9,250	73.3	9,500
35			33.1	7,100	51.4	6,350	60.4	6,400	66.2	6,800	70.2	6,950
40			16.6	5,100	44.4	4,700	55.5	4,850	62.3	5,100	66.9	5,200
45					36.5	3,500	50.3	3,650	58.3	3,850	63.5	3,950
50					26.5	2,500	44.7	2,700	54	2,850	60.1	3,000
55					9.3	1,700	38.4	1,900	49.6	2,100	56.5	2,200
60							31.1	1,250	44.9	1,500	52.8	1,600
65							21.6	750	39.7	950	48.9	1,050
70									33.9	500	44.9	650
95												
0		7,500	0	4,000	0	700						

30 FOOT JIB RATED LOADS		
LOAD RADIUS (ft)	LOADED BOOM ANGLE	30 ft JIB (lb)
30	78	5,500
35	76	5,450
40	74	5,400
45	71.4	4,300
50	68.7	3,250
55	66.1	2,500
60	63.4	1,800
65	60.6	1,250
70	57.9	800

*SHADED AREAS ARE STRUCTURALLY LIMITED CAPACITIES

THIS CHART IS ONLY A GUIDE AND SHOULD NOT BE USED TO OPERATE THE CRANE. The individual crane's load chart, operating instructions and other instructional plates must be read and understood prior to operating the crane.

1400A



capacities

Load Rating Chart: Series 14110A (33.5 m) Boom with 30'-54' (9.1-16.45 m) Jib / Full-Span Outrigger 24'6" (7.5 m)

Other Series 1400A Load Rating Charts are available. National will send you a chart on request – or you may secure needed load rating information through your nearest National dealer.

7

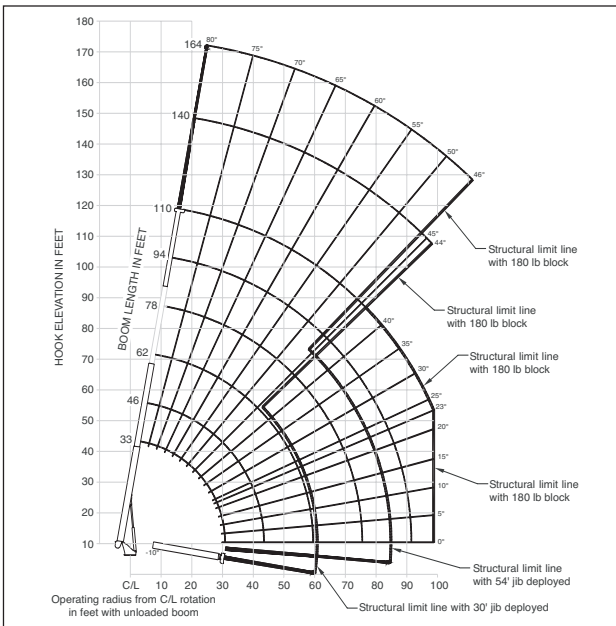

CAUTION:

- Do not operate crane booms, jib extensions, any accessories or loads within 10 ft (3m) of live power lines or other conductors of electricity.
- Jib and boom capacities shown are maximum for each section.
- Do not exceed capacities at reduced radii.
- Load ratings shown on the appropriate charts are maximum allowable loads with the crane mounted on a factory-approved truck and all outriggers at either full span or at mid span range and set on a firm level surface so that the crane is level and all tires are suspended.
- Always level the crane with the level indicator located on the crane.
- The operator must reduce load to allow for factors such as wind, ground conditions, operating speeds and their effects on freely suspended loads.
- Overloading this crane may cause structural collapse or instability.
- Weights on any accessories attached to the boom or loadline must be deducted from the load chart capacities.
- Do not exceed jib capabilities at any reduced boom lengths.
- Do not deadhead lineblock against boom tip when extending boom or winching up.
- Keep at least three wraps of loadline on drum at all times.
- Use only specified cable with this machine.

**SERIES 14110A
WITH
30'-54' JIB /
FULL-SPAN
OUTRIGGER 24'6"**

NOTE:

1. Operate with jib by radius when main boom is fully extended. If necessary increase boom angle to maintain loaded radius.
2. Operate with jib by boom angle when main boom is not fully extended. Do not exceed rated jib capacities at any reduced boom lengths.

LOADLINE EQUIPMENT DEDUCT

Downhaul weight.....	180 lb (81.6 kg)
One sheave block	375 lb (170 kg)
Two sheave block.....	640 lb (290 kg)
Three sheave block.....	870 lb (395 kg)
Four sheave block.....	970 lb (440 kg)

Load Rating Chart: Series 14110A (33.5 m) Boom with 30'-54' (9.1-16.45 m) Jib / Full-Span Outrigger 24'6" (7.5 m)

33 TO 110 FOOT BOOM RATED LOADS WITHOUT JIB

LOAD RADIUS (ft)	LOADED BOOM ANGLE	33 ft BOOM (lb)	LOADED BOOM ANGLE	A 46 ft BOOM (lb)	LOADED BOOM ANGLE	B 62 ft BOOM (lb)	LOADED BOOM ANGLE	C 78 ft BOOM (lb)	LOADED BOOM ANGLE	D 84 ft BOOM (lb)	LOADED BOOM ANGLE	110 ft BOOM (lb)	
6	76.7	66,000											
8	72.8	51,700											
10	68.9	42,200	76	37,000									
12	64.9	38,400	73.4	33,400	78.2	26,900							
15	58.6	32,200	69.3	28,000	75.6	24,900	79.4	22,800					
20	48.5	23,900	62.2	21,650	70.2	19,300	74.8	17,900	78.2	14,100			
25	33.3	17,600	54.4	17,800	64.9	16,050	71	14,550	75.1	12,400	77.4	9,200	
30			46.2	15,100	59.8	13,600	67	12,300	71.9	11,200	75.1	8,700	
35			36.3	12,750	54	12,050	63	10,600	68.5	9,750	72.5	8,000	
40			22.9	10,100	47.8	10,450	58.7	9,300	65.5	8,550	69.6	7,200	
45					41.6	8,750	54.5	7,800	61.9	7,350	67	6,400	
50					33.9	7,200	49.7	6,900	58.2	6,250	63.9	5,700	
55							44.5	6,000	54.4	5,500	60.8	4,700	
60							23.6	5,600					
65									38.6	4,900	50.5	4,000	
70									31.9	4,000	46.3	3,400	
75									23.3	3,250	41.7	2,700	
80									8.7	2,500	36.6	2,300	
85											30.7	2,250	
90											23.5	1,750	
95											12.5	1,250	
100												29.6	800
												23.3	600
	0	12,000	0	7,500	0	4,500	0	2,100	0	1,000			

30 TO 54 FOOT JIB RATED LOADS

LOAD RADIUS (ft)	LOADED BOOM ANGLE	30 ft JIB (lb)	LOADED BOOM ANGLE	54 ft JIB (lb)
30	79.1	5,050		
35	77.4	5,000	79.5	2,650
40	75.6	4,950	78.1	2,600
45	74.7	4,700	77.6	2,500
50	71.6	4,300	75	2,400
55	69.5	4,000	73.2	2,300
60	67.3	3,700	71.4	2,200
65	65.1	3,400	69.6	2,100
70	62.9	3,150	67.8	2,000
75	60.5	2,850	66	1,850
80	58	2,500	64.1	1,750
85	55.5	2,000	62.2	1,600
90	52.8	1,600	60.2	1,500
95	50	1,200	58	1,400
100	47.1	850	55.8	1,300
105	43.9	500	53.6	1,200
110			51.2	1,000
115			48.7	750
120			46.1	500

*SHADED AREAS ARE STRUCTURALLY LIMITED CAPACITIES

THIS CHART IS ONLY A GUIDE AND SHOULD NOT BE USED TO OPERATE THE CRANE. The individual crane's load chart, operating instructions and other instructional plates must be read and understood prior to operating the crane.

1400A



capacities

Load Rating Chart: Series 14110A (33.5 m) Boom with 30'-54' (9.1-16.45 m) Jib / Mid-Span Outrigger 17' (5.2 m)

8

Other Series 1400A Load Rating Charts are available. National will send you a chart on request – or you may secure needed load rating information through your nearest National dealer.

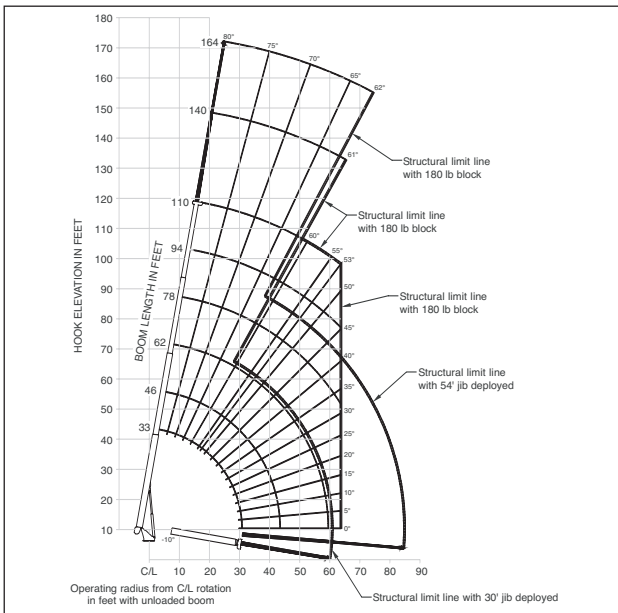

CAUTION:

- Do not operate crane booms, jib extensions, any accessories or loads within 10 ft (3m) of live power lines or other conductors of electricity.
- Jib and boom capacities shown are maximum for each section.
- Do not exceed capacities at reduced radii.
- Load ratings shown on the load rating charts are maximum allowable loads with the outriggers properly extended and the outrigger lock pins engaged on a firm, level surface and the crane leveled and mounted on a factory recommended truck.
- Always level the crane with the level indicator located on the crane.
- The operator must reduce load to allow for factors such as wind, ground conditions, operating speeds and their effects on freely suspended loads.
- Overloading this crane may cause structural collapse or instability.
- Weights on any accessories attached to the boom or loadline must be deducted from the load chart capacities.
- Do not exceed jib capabilities at any reduced boom lengths.
- Do not deadhead lineblock against boom tip when extending boom or winching up.
- Keep at least three wraps of loadline on drum at all times.
- Use only specified cable with this machine.

**SERIES 14110A
WITH
30'-54' JIB
MID-SPAN
OUTRIGGER 17'**

**LOADLINE EQUIPMENT
DEDUCT**

- Downhaul weight.....180 lb (81.6 kg)
- One sheave block375 lb (170 kg)
- Two sheave block.....640 lb (290 kg)
- Three sheave block.....870 lb (395 kg)
- Four sheave block.....970 lb (440 kg)

NOTE:

1. Operate with jib by radius when main boom is fully extended. If necessary increase boom angle to maintain loaded radius.
2. Operate with jib by boom angle when main boom is not fully extended. Do not exceed rated jib capacities at any reduced boom lengths.

Load Rating Chart: Series 14110A (33.5 m) Boom with 30'-54' (9.1-16.45 m) Jib / Mid-Span Outrigger 17' (5.2 m)

33 TO 110 FOOT BOOM RATED LOADS WITHOUT JIB

LOAD RADIUS (ft)	LOADED BOOM ANGLE	33 ft BOOM (lb)	LOADED BOOM ANGLE	A 46 ft BOOM (lb)	LOADED BOOM ANGLE	B 62 ft BOOM (lb)	LOADED BOOM ANGLE	C 78 ft BOOM (lb)	LOADED BOOM ANGLE	D 94 ft BOOM (lb)	LOADED BOOM ANGLE	110 ft BOOM (lb)	
6	76.7	66,000											
8	72.8	51,700											
10	68.9	42,200	76	37,000									
12	64.9	38,400	73.4	33,400	78.2	26,900							
15	58.6	32,200	69.3	28,000	75.6	24,900	79.4	22,800					
20	46.9	18,500	62.2	21,650	70.2	19,300	74.8	17,900	78.2	14,100			
25	32.3	11,000	54.4	14,000	64.7	12,800	70.8	13,200	75.1	12,400	77.4	9,200	
30			45.9	9,500	59.8	8,600	67	9,100	71.7	9,200	75.1	8,700	
35			36.9	7,000	54	6,200	62.8	6,400	68.2	6,800	72.2	7,000	
40			23.9	4,800	47.8	4,500	58.2	4,600	64.7	5,000	69	5,200	
45					40.9	3,200	54	3,400	61	3,600	65.9	3,900	
50					33.1	2,100	48.8	2,500	57.4	2,600	62.9	2,800	
55						22.8	1,300	43.5	1,700	53.4	1,900	2,000	
60								37.7	1,100	49.4	1,300	56.6	1,400
65									31	600	45.1	750	900
	0	7,000	0	3,600	0	500							

30 TO 54 FOOT JIB RATED LOADS				
LOAD RADIUS (ft)	LOADED BOOM ANGLE	30 ft JIB (lb)	LOADED BOOM ANGLE	54 ft JIB (lb)
30	79.1	5,050		
35	77.4	5,000	79.5	2,650
40	75.6	4,950	78.1	2,600
45	73.4	4,300	77.6	2,500
50	70.9	3,250	75	2,400
55	68.4	2,400	73.2	2,300
60	65.9	1,750	71.4	2,200
65	63.4	1,150	69	1,900
70	60.8	700	66.7	1,450
75			64.5	1,050
80			62.1	650

*SHADED AREAS ARE STRUCTURALLY LIMITED CAPACITIES

1400A

THIS CHART IS ONLY A GUIDE AND SHOULD NOT BE USED TO OPERATE THE CRANE. The individual crane's load chart, operating instructions and other instructional plates must be read and understood prior to operating the crane.



capacities

Load Rating Chart: Series 14127A (38.7 m) Boom with 30' (9.1 m) Jib / Full-Span Outrigger 24'6" (7.5 m)

Other Series 1400A Load Rating Charts are available. National will send you a chart on request – or you may secure needed load rating information through your nearest National dealer.

9

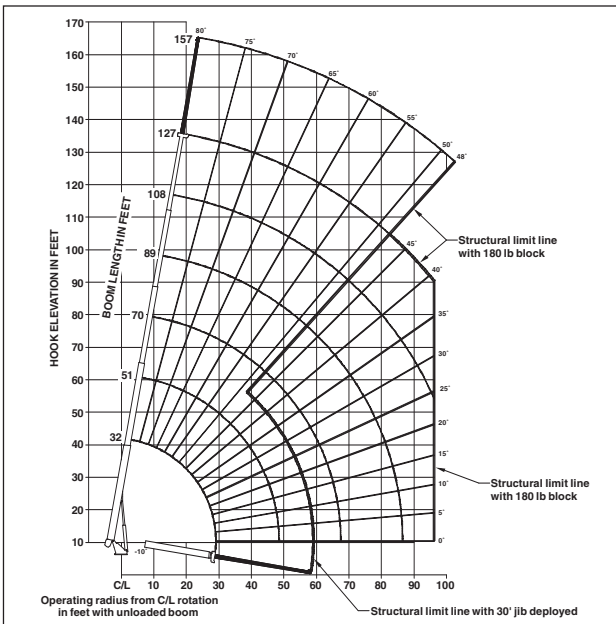

CAUTION:

- Do not operate crane booms, jib extensions, any accessories or loads within 10 ft (3m) of live power lines or other conductors of electricity.
- Jib and boom capacities shown are maximum for each section.
- Do not exceed capacities at reduced radii.
- Load ratings shown on the appropriate charts are maximum allowable loads with the crane mounted on a factory-approved truck and all outriggers at either full span or at mid span range and set on a firm level surface so that the crane is level and all tires are suspended.
- Always level the crane with the level indicator located on the crane.
- The operator must reduce load to allow for factors such as wind, ground conditions, operating speeds and their effects on freely suspended loads.
- Overloading this crane may cause structural collapse or instability.
- Weights on any accessories attached to the boom or loadline must be deducted from the load chart capacities.
- Do not exceed jib capabilities at any reduced boom lengths.
- Do not deadhead lineblock against boom tip when extending boom or winching up.
- Keep at least three wraps of loadline on drum at all times.
- Use only specified cable with this machine.

**SERIES 14127A
WITH
30' JIB /
FULL-SPAN
OUTRIGGER 24'6"**

NOTE:

1. Operate with jib by radius when main boom is fully extended. If necessary increase boom angle to maintain loaded radius.
2. Operate with jib by boom angle when main boom is not fully extended. Do not exceed rated jib capacities at any reduced boom lengths.

**LOADLINE EQUIPMENT
DEDUCT**

- Downhaul weight.....180 lb (81.6 kg)
- One sheave block375 lb (170 kg)
- Two sheave block.....640 lb (290 kg)
- Three sheave block.....870 lb (395 kg)
- Four sheave block.....970 lb (440 kg)

Load Rating Chart: Series 14127A (38.7 m) Boom with 30' (9.1 m) Jib / Full-Span Outrigger 24'6" (7.5 m)

32 TO 127 FOOT BOOM RATED LOADS WITHOUT JIB

LOAD RADIUS (ft)	LOADED BOOM ANGLE	32 ft BOOM (lb)	LOADED BOOM ANGLE	A 51 ft BOOM (lb)	LOADED BOOM ANGLE	B 70 ft BOOM (lb)	LOADED BOOM ANGLE	C 89 ft BOOM (lb)	LOADED BOOM ANGLE	D 108 ft BOOM (lb)	LOADED BOOM ANGLE	127 ft BOOM (lb)
6	76.5	66,000										
8	72.3	48,050										
10	68.2	41,250	77.6	33,000								
12	64	36,300	75.6	30,050								
15	57.4	30,700	71.7	26,200	77.5	22,800						
20	45.2	24,550	65.5	20,750	73.3	19,200	77.7	16,800				
25	29.2	19,900	59	17,050	68.9	15,600	74.5	14,400	78	12,400		
30			51.9	14,600	64.3	13,100	71	12,050	75.3	10,700	77.9	8,000
35			44	12,550	59.5	10,900	67.4	9,900	72.7	9,200	75.9	7,700
40			34.6	10,100	54.5	9,400	64.1	8,500	69.9	8,000	73.7	7,300
45			23.4	8,050	49.6	8,250	60.4	7,400	66.9	6,900	71.4	6,500
50					43.7	7,050	56.4	6,350	63.8	5,650	68.8	5,650
55					36.9	5,900	52.3	5,700	60.7	4,950	66.2	4,700
60					28.9	4,800	48	5,100	57.4	4,350	63.3	3,600
65					17.5	3,850	43.1	4,200	54.1	3,900	60.7	3,200
70							37.8	3,400	50.6	3,450	58	2,800
75							31.7	2,700	46.8	2,850	55.2	2,500
80							24.2	2,150	42.8	2,300	52.3	2,200
85							12.8	1,600	38.4	1,800	49.3	1,950
90									33.4	1,350	46	1,500
95									27.7	950	42.4	1,100
100									20.6	600	38.7	750
0		12,800	0	5,400	0	2,600	0	1,100				

30 FOOT JIB RATED LOADS		
LOAD RADIUS (ft)	LOADED BOOM ANGLE	30 ft JIB (lb)
35	78.6	3,850
40	77.1	3,700
45	75.4	3,550
50	73.8	3,400
55	72.1	3,250
60	70.3	3,100
65	68.5	2,950
70	66.5	2,700
75	64.5	2,550
80	62.4	2,300
85	60.2	2,100
90	58	1,850
95	55.6	1,650
100	53.2	1,300
105	50.6	950
110	47.8	650

*SHADED AREAS ARE STRUCTURALLY LIMITED CAPACITIES

THIS CHART IS ONLY A GUIDE AND SHOULD NOT BE USED TO OPERATE THE CRANE. The individual crane's load chart, operating instructions and other instructional plates must be read and understood prior to operating the crane.

1400A



capacities

10

Load Rating Chart: Series 14127A (38.7 m) Boom with 30' (9.1 m) Jib / Mid-Span Outrigger 17' (5.2 m)

Other Series 1400A Load Rating Charts are available. National will send you a chart on request – or you may secure needed load rating information through your nearest National dealer.

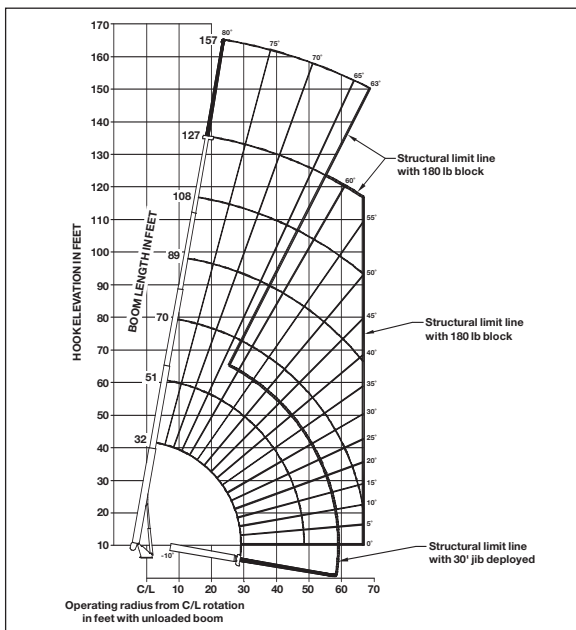

CAUTION:

- Do not operate crane booms, jib extensions, any accessories or loads within 10 ft (3m) of live power lines or other conductors of electricity.
- Jib and boom capacities shown are maximum for each section.
- Do not exceed capacities at reduced radii.
- Load ratings shown on the load rating charts are maximum allowable loads with the outriggers properly extended and the outrigger lock pins engaged on a firm, level surface and the crane leveled and mounted on a factory recommended truck.
- Always level the crane with the level indicator located on the crane.
- The operator must reduce load to allow for factors such as wind, ground conditions, operating speeds and their effects on freely suspended loads.
- Overloading this crane may cause structural collapse or instability.
- Weights on any accessories attached to the boom or loadline must be deducted from the load chart capacities.
- Do not exceed jib capabilities at any reduced boom lengths.
- Do not deadhead lineblock against boom tip when extending boom or winching up.
- Keep at least three wraps of loadline on drum at all times.
- Use only specified cable with this machine.

**SERIES 14127A
WITH
30' JIB /
MID-SPAN
OUTRIGGER 17'**

**LOADLINE EQUIPMENT
DEDUCT**

- Downhaul weight.....180 lb (81.6 kg)
- One sheave block375 lb (170 kg)
- Two sheave block.....640 lb (290 kg)
- Three sheave block.....870 lb (395 kg)
- Four sheave block.....970 lb (440 kg)

NOTE:

1. Operate with jib by radius when main boom is fully extended. If necessary increase boom angle to maintain loaded radius.
2. Operate with jib by boom angle when main boom is not fully extended. Do not exceed rated jib capacities at any reduced boom lengths.

Load Rating Chart: Series 14127A (38.7 m) Boom with 30' (9.1 m) Jib / Mid-Span Outrigger 17' (5.2 m)

32 TO 127 FOOT BOOM RATED LOADS WITHOUT JIB

LOAD RADIUS (ft)	LOADED BOOM ANGLE	32 ft BOOM (lb)	LOADED BOOM ANGLE	A 51 ft BOOM (lb)	LOADED BOOM ANGLE	B 70 ft BOOM (lb)	LOADED BOOM ANGLE	C 89 ft BOOM (lb)	LOADED BOOM ANGLE	D 108 ft BOOM (lb)	LOADED BOOM ANGLE	127 ft BOOM (lb)	
6	76.5	66,000											
8	72.3	48,050											
10	68.2	41,250	77.6	33,000									
12	64	36,300	75.6	30,050									
15	57.4	30,700	71.7	26,200	77.5	22,800							
20	45	18,700	65.5	20,750	73.3	19,200	77.7	16,800					
25	29	11,200	58.7	12,900	68.7	13,500	74.4	14,100	78	12,400			
30			52.1	8,700	63.9	9,250	70.6	9,700	75.1	10,050	77.9	8,000	
35			44.2	6,000	59.4	6,500	67.2	6,950	72.2	7,300	75.9	7,500	
40			35	4,200	54.2	4,700	63.4	5,150	69.1	5,350	73.5	5,800	
45			22.8	2,800	48.8	3,400	59.5	3,750	66	3,950	70.7	4,200	
50					42.8	2,350	55.5	2,700	62.8	2,850	68	3,100	
55					36.1	1,550	51.3	1,850	59.6	2,000	65.3	2,200	
60						28	850	46.8	1,200	56.3	1,350	62.6	1,450
65								42	650	52.9	750	59.8	900
70												57	500
	0	7,800	0	2,000									

30 FOOT JIB RATED LOADS		
LOAD RADIUS (ft)	LOADED BOOM ANGLE	30 ft JIB (lb)
35	78.6	3,850
40	77.1	3,700
45	75.4	3,550
50	73.8	3,400
55	72.1	2,800
60	70	2,100
65	67.8	1,500
70	65.5	1,000
75	63.2	550

1400A

*SHADED AREAS ARE STRUCTURALLY LIMITED CAPACITIES

THIS CHART IS ONLY A GUIDE AND SHOULD NOT BE USED TO OPERATE THE CRANE. The individual crane's load chart, operating instructions and other instructional plates must be read and understood prior to operating the crane.



accessories

11

Radio Remote Controls –

Eliminate the handling and maintenance concerns that accompany cabled remotes. Operate to a range of about 250 feet (76 m), varying with conditions.

- **NB4R**

One-Person Basket –

Strong but lightweight steel basket with 300-lb. (139-kg) capacity, gravity hung with swing lock and full body harness.

- **B1-S**
- **2B1-S** (for dual locking baskets)

Heavy-duty Personnel Basket –

1,200-lb. (544-kg) capacity steel basket with safety loops for four passengers. Gravity leveling 72- x 42-inch (183- x 107-cm) platform. Fast attachment and secure locking systems. Load chart must show 2,300 lb. (1043 kg) minimum to operate this accessory.

- **BSA-1**
- **BSA-R1** (provides rotation)

Air Conditioning –

Back of cab mounted – self contained modular unit with in-cab cool air outlets. Requires 130+ amp. chassis alternator.

- **AC**

Last Layer Indicator Option on winch with indicator in cab.

- **LLI**

Winchdown Rotation Indicator –

Has “thumper” in the cab winch lever to indicate to the operator that the winch is in motion.

- **WDRI**

Outrigger Controls at operator’s seat in addition to ground controls.

- **ICORC**

Outrigger Motion Alarms –

Available for “A” frame O/R and ASH stabilizers.

- **OMA-1**

Hour Meter –

Hour meter in truck cab to record crane operation hours.

- **HRM**

Open Seat Controls

- **SSC**

Auxiliary Winch –

9,000 lbs. line pull with 375' of 5/8" diameter rotation-resistant wire rope.

Steel Tool Box

Spanish-Language Danger Decals, Control Knobs, and Operators’ Manuals

- **SDD**
- **SOM**

1400A



dimensions specifications

Dimensions Specifications

12

1400A

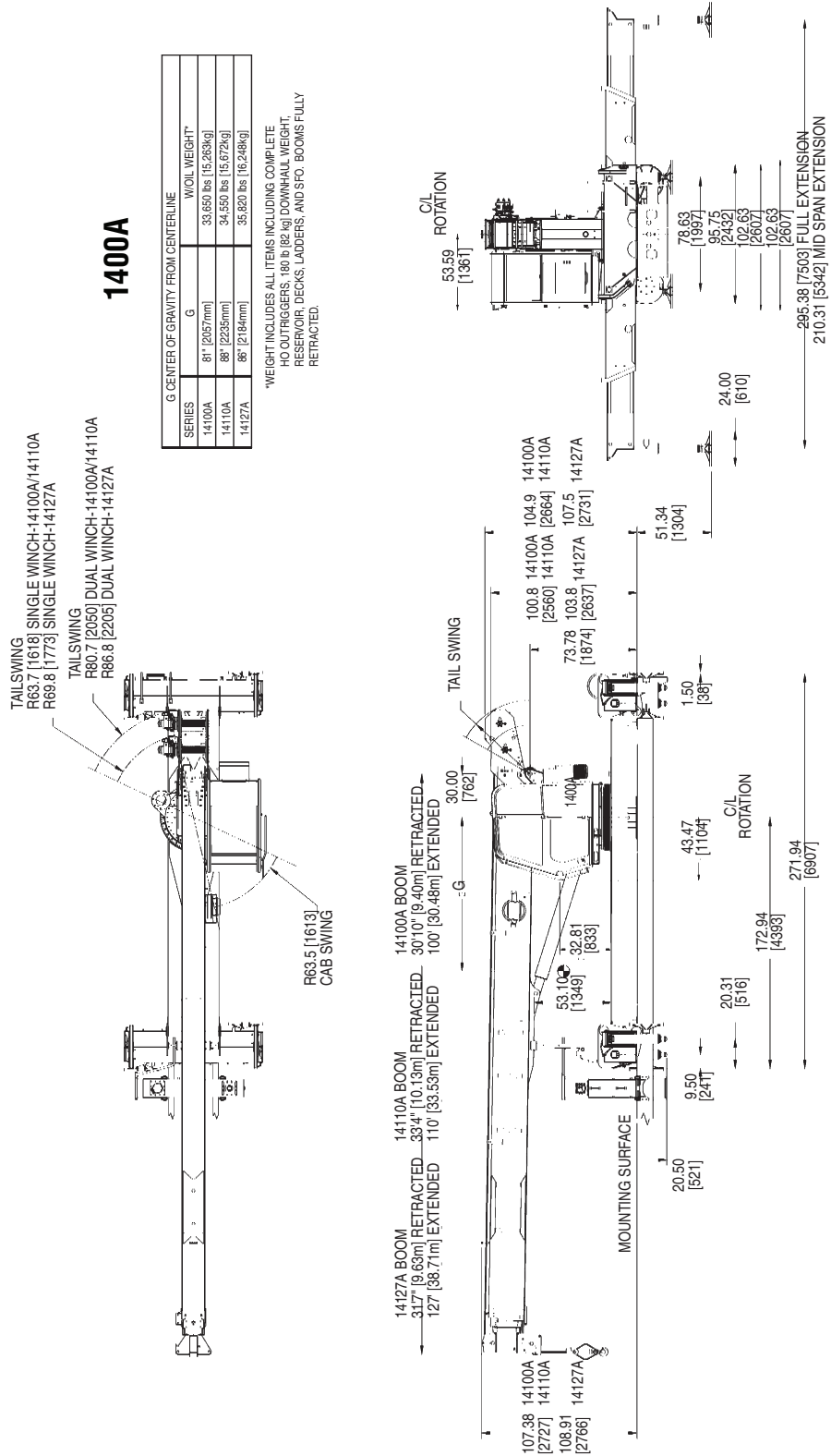

notes**13****1400A**

notes**14****1400A**

notes**15****1400A**



Regional Headquarters

Americas

Manitowoc, Wisconsin, USA

Tel: +1 920 684 6621
Fax: +1 920 683 6278

Shady Grove, Pennsylvania, USA

Tel: +1 717 597 8121
Fax: +1 717 597 4062

Regional Offices

Americas

Brazil

Alphaville
Tel: +55 11 4688 2716
Fax: +55 11 4191 1471

Mexico

Monterrey
Tel: +52 81 8124 0128
Fax: +52 81 8124 0129

Europe, Middle East, Africa

Algeria

Hydra
Tel: +21 3 21 48 1173
Fax: +21 3 21 48 1454

Czech Republic

Netovice
Tel: +420 317 78 9313
Fax: +420 317 78 9314

France

Baudemont
Tel: +33 385 28 2589
Fax: +33 385 28 0430

Cergy

Tel: +33 130 31 3150
Fax: +33 130 38 6085

Decines

Tel: +33 472 81 5000
Fax: +33 472 81 5010

Germany

Langenfeld
Tel: +49 21 73 8909-0
Fax: +49 21 73 8909 30

Hungary

Budapest
Tel: +36 13 39 8622
Fax: +36 13 39 8622

Italy

Parabiago
Tel: +390 331 49 3311
Fax: +390 331 49 3330

Europe, Middle East, Africa

Ecully, France

Tel: +33 472 18 2020
Fax: +33 472 18 2000

Netherlands

Breda
Tel: +31 76 578 3999
Fax: +31 76 578 3978

Poland

Warsaw
Tel: +48 22 843 3824
Fax: +48 22 843 3471

Portugal

Alfena
Tel: +351 229 69 8840
Fax: +351 229 69 8848

Lisbon

Tel: +351 212 109 340
Fax: +351 212 109 349

Russia

Moscow
Tel: +7 495 641 2359
Fax: +7 495 641 2358

U.A.E.

Dubai
Tel: +971 4 3381 861
Fax: +971 4 3382 343

U. K.

Middlesex
Tel: +44 1 895 43 0053
Fax: +44 1 895 45 9500

Sunderland

Tel: +44 191 522 2000
Fax: +44 191 522 2052

Asia – Pacific

Australia

Melbourne
Tel: +61 3 9 336 1300
Fax: +61 3 9 336 1322

Sydney

Tel: +61 2 9 896 4433
Fax: +61 2 9 896 3122

Asia – Pacific

Shanghai, China

Tel: +86 21 51113579
Fax: +86 21 51113578

Singapore

Tel: +65 6264 1188
Fax: +65 6862 4142

China

Beijing
Tel: +86 10 58674761
Fax: +86 10 58674760

Xi'an

Tel: +86 29 87891465
Fax: +86 29 87884504

Korea

Seoul
Tel: +82 2 3439 0400
Fax: +82 2 3439 0405

Philippines

Makati City
Tel: +63 2 844 9437
Fax: +63 2 844 4712

Factories

U.S.A.

Manitowoc
Shady Grove

Brazil

Alphaville

France

Charlieu
La Clayette
Moulines

India

Calcutta
Puna

Italy

Niella Tanaro

Germany

Wilhelmshaven

Portugal

Fânzeres

China

Zhangjiagang



Constant improvement and engineering progress make it necessary that we reserve the right to make specification, equipment and price changes without notice. Illustrations shown may include optional equipment and accessories, and may not include all standard equipment.



www.manitowoccrane.com

