



Series 1800

product guide

features

- 142 ft (43.28 m) Five-Section Boom
- 40 USt (36.29 t) Rating
- Self-lubricating "Easy Glide" Wear Pads
- Tailswing Counterweight



contents

Features	2
Mounting Configurations	3
Specifications	4
Capacities	5
Accessories	13
Dimensions Specifications	14



www.manitowoccrane.com

*Product may be shown with optional equipment.

features

Why Buy a National Crane Series 1800?

2



*Product may be shown with optional equipment.

- **40 USt (36.29 t) maximum capacity**
- **190 ft (57.91 m) maximum vertical reach***
- **149 ft (45.42 m) maximum vertical hydraulic reach***
- **Load Moment Indicator system (LMI)**
- **Proportional boom extension**
- **High performance planetary winch**
- **Vickers PVH 131 pressure compensated, load sensing, axial piston, variable volume pump mounts direct to PTO.**
- * **Maximum vertical reach is ground-level to boom tip height at maximum extension and angle with outriggers/stabilizers fully extended.**
- **40 USt (36.29 t) Rating** – The 1800 provides a 40 USt capacity, an 11% increase in capacity over the Series 1500.
- **142 ft (43.28 m) Five-section Boom** – The longest in its size range. The long boom allows the operator to perform more lifts without the use of a jib, reducing setup time and improving efficiency. Also available are optional boom lengths of 79 ft, 103 ft and 127 ft.
- **Overload Protection** – All National Crane boom trucks are equipped with overload protection:
 - Load Moment Indicator (LMI) standard on all Series 1800 machines.
 - LMI display and CPU are weatherproof.
 - LCD display is visible in full or low light.
 - All crane load lifting values are displayed simultaneously.
- **Stronger Torsion Box** – The stronger standard torsion box improves rigidity, reduces truck frame flex and reduces the need for counterweight.
- **Speedy-reeve Boom Tip and Sheave Blocks** – These standard features simplify rigging changes by decreasing the time needed to change line reeving.
- **Pre-painted Components** – Painting crane components before assembly reduces the possibility of rust, improves serviceability and enhances the appearance of the machine.
- **Self-lubricating “Easy Glide” Boom Wear Pads** – The standard self-lubricating boom pads reduce the conditions that cause boom chatter and vibration. The net result is smoother crane operation.
- **Deluxe Operator’s Cab** – Rigid galvanized steel structure, well insulated, with ample safety glass for operator visibility and comfort. Multi-position seat with arm rest controls, ventilation fans, diesel heater, wipers. Optional air conditioning is available.
- **Outrigger** – Outrigger span of 24.7 ft when fully extended; 17.5 ft at mid-span.
 - Ground-level outrigger controls on both sides.
 - In-cab outrigger controls for all functions.
 - Front bumper stabilizer for stable base over front.
- **Electronic versions of manuals available through Manitowoc Crane CARE.**
- **Improved Serviceability** –
 - Boom sections are supported by one hydraulic extend cylinder, minimizing maintenance.
 - Bearings on the boom extend and retract cables can be greased through access holes in the boom side plates.
 - Pre-paint reduces rust.
- **New State-of-the-art Control Valve** – Provides smoother operation. The new load-sensing, pressure-compensated design greatly enhances function meterability, eliminates parts, reduces repair costs and improves the machine’s serviceability.
- **National Crane is the Market Leader** – National Crane is number one in the production of commercial truck-mounted boom trucks, with more than 35,000 units sold. National Crane has the resources, programs and people to provide our customers with reliable products.
- **National Crane has the boom truck industry’s leading test program.** Every structural part of the crane is cycle tested, some up to 60,000 cycles at full capacity. In addition to cycle testing, each model is subjected to state-of-the-art strain gauge testing that measures metal deformation as small as one one-millionth of an inch. The net result is that weak areas are caught in test, not on job sites where costly downtime occurs.
- **Parts are available for all National Crane machines for the life of the crane.**
- **National Crane has a formalized quality program and is ISO 9001 approved.**

1800



mounting configurations

The configurations are based on the Series 1800 with an 85% stability factor. The complete unit must be installed in accordance with factory requirements and a test performed to determine actual stability and counterweight requirements since individual truck chassis vary.

1800 w/Tag Axle 60,000 GVWR (79/103/127 ft Boom)

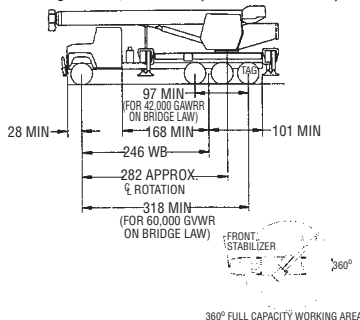

Configuration 1: 79 ft (24.08 m), 103 ft (31.39 m) 127 ft (38.71 m) Boom with Tag Axle

Working area360°
Gross Axle Weight Rating Front20,000 lb (9 072 kg)
Gross Axle Weight Rating Rear40,000 lb (18 144 kg)
Gross Vehicle Weight Rating60,000 lb (27 216 kg)
Wheelbase246 in (625 cm)
Cab to Axle/trunnion (CA/CT)168 in (427 cm)
Frame Section Modulus (SM), front axle to end of AF: 110,000 PSI (785 MPa)30.0 in ³ (426 cm ³)
Stability Weight, Front9,450 lb (4 286 kg) minimum*
Stability Weight, Rear10,800 lb (4 899 kg) minimum*
Estimated Average Final Weight56,945 lb (25 830 kg)**

This configuration shows the 360° working area that is achieved with the front stabilizer (standard on the Series 1800). The front stabilizer is essential when extending the boom and lifting loads over the front of the truck.

*Estimated axle scale weights prior to installation of crane, stabilizers and subbase for 85% stability.

**Estimated final weight (wet) with 127 ft (38.71 m) boom, 400 lb (182 kg) 3 part block, steel decks, 2,300 lb (1,045 kg) swinging counterweight, 100 gal (379 L) fuel tank and two workers in cab.

1800 w/Pusher Axle 58,000 GVWR (79/103/127 ft Boom)

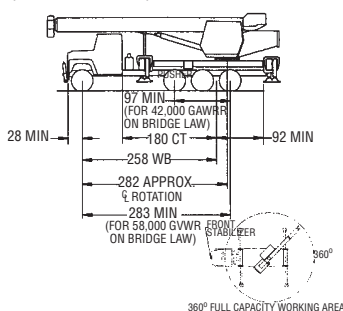

Configuration 2: 79 ft (24.08 m), 103 ft (31.39 m) 127 ft (38.71 m) Boom with Pusher Axle

Working area360°
Gross Axle Weight Rating Front20,000 lb (9 072 kg)
Gross Axle Weight Rating Rear40,000 lb (18 144 kg)
Gross Vehicle Weight Rating60,000 lb (27 216 kg)
Wheelbase258 in (655 cm)
Cab to Axle/trunnion (CA/CT)180 in (457 cm)
Frame Section Modulus (SM), front axle to end of AF: 110,000 PSI (785 MPa)30.0 in ³ (426 cm ³)
Stability Weight, Front9,975 lb (4 525 kg) minimum*
Stability Weight, Rear10,275 lb (4 661 kg) minimum*
Estimated Average Final Weight56,945 lb (25 830 kg)**

This configuration shows the 360° working area that is achieved with the front stabilizer (standard on the Series 1800). The front stabilizer is essential when extending the boom and lifting loads over the front of the truck.

*Estimated axle scale weights prior to installation of crane, stabilizers and subbase for 85% stability.

**Estimated final weight (wet) with 127 ft (38.71 m) boom, 400 lb (182 kg) 3 part block, steel decks, 2,300 lb (1,045 kg) swinging counterweight, 100 gal (379 L) fuel tank and two workers in cab.

1800 w/Tag Axle 60,000 GVWR (142 ft Boom)

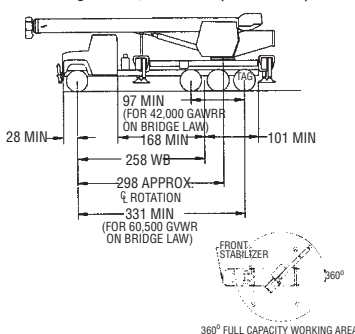

Configuration 3: 142 ft (43.29 m) Boom with Tag Axle

Working area360°
Gross Axle Weight Rating Front20,000 lb (9 072 kg)
Gross Axle Weight Rating Rear40,000 lb (18 144 kg)
Gross Vehicle Weight Rating60,000 lb (27 216 kg)
Wheelbase258 in (655 cm)
Cab to Axle/trunnion (CA/CT)168 in (427 cm)
Frame Section Modulus (SM), front axle to end of AF: 110,000 PSI (785 MPa)30.0 in ³ (426 cm ³)
Stability Weight, Front9,275 lb (4 207 kg) minimum*
Stability Weight, Rear10,575 lb (4 797 kg) minimum*
Estimated Average Final Weight58,000 lb (26 308 kg)**

This configuration shows the 360° working area that is achieved with the front stabilizer (standard on the Series 1800). The front stabilizer is essential when extending the boom and lifting loads over the front of the truck.

*Estimated axle scale weights prior to installation of crane, stabilizers and subbase for 85% stability.

**Estimated final weight (wet) with 142 ft (43.29 m) boom, 400 lb (182 kg) 3 part block, steel decks, 2,300 lb (1,045 kg) swinging counterweight, 100 gal (379 L) fuel tank and two workers in cab.

MINIMUM TRUCK REQUIREMENTS

Many factors must be considered in the selection of proper truck for a 1800 series crane. Items which must be considered are:

- 1. Axle Rating.** Axle ratings are determined by the axles, tires, rims, springs, brakes, steering and frame strength of the truck. If any one of these components is below the required rating, the gross axle rating is reduced to its weakest component value.
- 2. Wheelbase (WB), Cab-to-Trunnion (CT) and Bare Chassis Weight.** The wheelbase, CT and chassis weights shown are required so the basic 1800 can be legally driven in most states and meet stability requirements. The dimensions given assume the sub-base is installed properly behind the truck cab. If exhaust stacks, transmission protrusions, etc., do not allow a close installation to the cab, the WB and CT dimensions must be increased. Refer to the Mounting Configuration pages for additional information.
- 3. Truck Frame.** Try to select a truck frame that will minimize or eliminate frame reinforcement or extension of the after frame (AF). Many frames are

available that have the necessary after frame (AF) section modulus (SM) and resistance to bending moment (RBM) so that reinforcing is not required. The front hydraulic jack is used for a 360° working range around the truck. The frame under the cab through the front suspension must have the minimum S.M. and RBM because reinforcing through the front suspension is often difficult because of engine, radiator mounts and steering mechanics. See "Truck Requirements" and "Frame Strength" pages for the necessary section modulus and resistance to bending moment values.

- 4. Additional Equipment.** In addition to the axle ratings, wheelbase, cab-to-axle requirements and frame, it is recommended that the truck is equipped with electronic engine control, increased cooling and a transmission with a PTO opening available with an extra heavy duty PTO. See "PTO Selection" pages. A conventional cab truck should be used for standard crane mounts.
- 5. Neutral Start Switch.** The chassis must be equipped with a switch that prevents operation of the engine starter when the transmission is in gear.

Notes:

- Gross Vehicle Weight Rating (GVWR) is dependent on all components of the vehicle (axles, tires, springs, frame, etc.) meeting manufacturers' recommendations; always specify GVWR when purchasing trucks
- Diesel engines require a variable speed governor and energize-to-run fuel solenoid for smooth crane operation; electronic fuel injection requires EET engine remote throttle
- All mounting data is based on a National Series 1800 with an 85 percent stability factor (75% stability factor for New York City).
- The complete unit must be installed in accordance with factory requirements, and a test performed to determine actual stability and counterweight requirements per SAE J765; contact the factory for details

3

1800



specifications

Boom and Jib Combinations Data

4

Available in four basic models:

Model 1879 – Equipped with a 31-79 ft (9.45-24.08 m) three-section boom. There are no jib options for this boom model. Maximum tip height is 87 ft (26.52 m).

31-79 ft (9.45-24.08 m) three-section hydraulic boom



Model 18103 – Equipped with a 31-103 ft (9.45-31.39 m) four-section boom. This model can be equipped with a 31 ft (9.45 m) jib, offering a vertical reach of 142 ft (43.29 m) and a 31-55 ft (9.45-16.76 m) side-stowing foldaway jib, providing a vertical reach of 166 ft (50.60 m).

31-103 ft (9.45-31.39 m) four-section hydraulic boom **18FJ31OS** 31 ft (9.45 m) single-section offsettable manual jib



31-103 ft (9.45-31.39 m) four-section hydraulic boom **18FJ55** 31-55 (9.45-16.76 m) two-section manual jib



Model 18127 – Equipped with a 31-127 ft (9.45-38.71 m) five-section boom. This model can be equipped with a 31 ft (9.45 m) jib, offering a vertical reach of 166 ft (50.60 m) or a 31-55 ft (9.45-16.76 m) jib providing a vertical reach of 190 ft (57.91 m).

31-127 ft (9.45-38.71 m) five-section hydraulic boom **18FJ31** 31 ft (9.45 m) single-section manual jib



31-127 ft (9.45-38.71 m) five-section hydraulic boom **18FJ55** 31-55 (9.45-16.76 m) two-section manual jib



Model 18142 – Equipped with a 34-142 ft (10.36-43.29 m) five-section boom. This model can be equipped with a 26 ft (7.92 m) jib, offering a vertical reach of 176 ft (53.64 m).









34-142 ft (10.36-43.29 m) five-section hydraulic boom **18FJ26** 26 ft (7.92 m) single-section manual jib



Note: maximum tip height is measured with outriggers/stabilizers fully extended.

1800 Winch Data

- All winch pulls and speeds are shown on the fifth layer.
- Winch line pulls would increase on the first, second, third and fourth layers.
- Winch line speed would decrease on the first, second, third and fourth layers.
- Winch line pulls may be limited by the winch capacity or the ANSI 5 to 1 cable safety factor.

			1 Part Line	2 Part Line	3 Part Line	4 Part Line	5 Part Line	6 Part Line	7 Part Line	8 Part Line
										
Standard Planetary Winch	Cable Supplied	Average Breaking Strength	Lift and Speed	Lift and Speed	Lift and Speed	Lift and Speed	Lift and Speed	Lift and Speed	Lift and Speed	Lift and Speed
Low Speed	5/8" diameter rotation resistant IWRC	56,400 lb (25583 kg)	10,000 lb (4536 kg) 205 fpm (62 m/min)	20,000 lb (9072 kg) 103 fpm (31 m/min)	30,000 lb (13608 kg) 68 fpm (21 m/min)	40,000 lb (18144 kg) 51 fpm (16 m/min)	50,000 lb (22680 kg) 41 fpm (13 m/min)	60,000 lb (27216 kg) 34 fpm (10 m/min)	70,000 lb (31751 kg) 29 fpm (9 m/min)	80,000 lb (36287 kg) 26 fpm (8 m/min)
High Speed	5/8" diameter rotation resistant IWRC	56,400 lb (25583 kg)	5,000 lb (2268 kg) 410 fpm (125 m/min)	10,000 lb (4536 kg) 205 fpm (62 m/min)	15,000 lb (6804 kg) 137 fpm (42 m/min)	20,000 lb (9072 kg) 103 fpm (31 m/min)	25,000 lb (11340 kg) 82 fpm (25 m/min)	30,000 lb (13608 kg) 68 fpm (21 m/min)	35,000 lb (15876 kg) 59 fpm (18 m/min)	40,000 lb (18144 kg) 51 fpm (16 m/min)

1800

Winch
Standard planetary & Auxiliary planetary

Full Drum Pull
5,000 lb (2268 kg high speed)
10,000 lb (4536 kg low speed)

Allowable Cable Pull
11,280 lb (5117 kg)
11,280 lb (5117 kg)

LOADLINE DEDUCT

Aux Boom Head	100 lb (45 kg)
Downhaul Weight	180 lb (82 kg)
5 USt 1 Sheave Block	375 lb (170 kg)
25 USt 2 Sheave Block	640 lb (290 kg)
35 USt 3 Sheave Block	870 lb (395 kg)
40 USt 4 Sheave Block	970 lb (440 kg)



capacities

Load Rating Chart: Series 1879 (24.08 m) Boom/Full-Span Outrigger 24.7 ft (7.6 m)

National Crane will send you a chart on request – or you may secure needed load rating information through your nearest National Crane dealer.

5

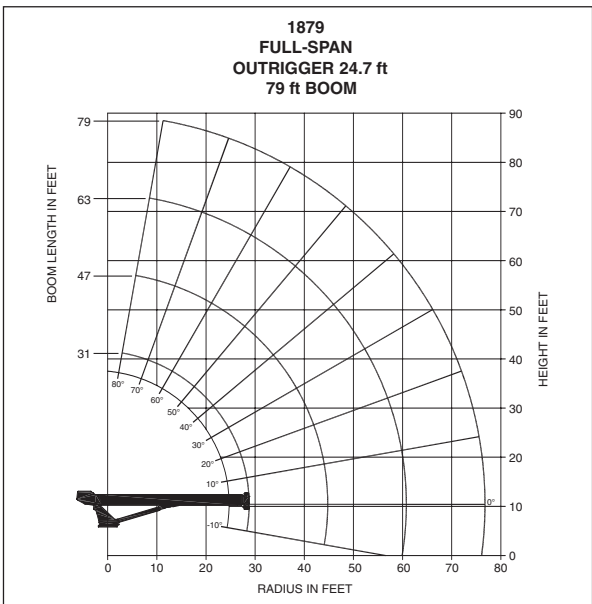

CAUTION:

- Do not operate crane booms, jib extensions, any accessories or loads within 10 ft (3m) of live power lines or other conductors of electricity.
- Jib and boom capacities shown are maximum for each section.
- Do not exceed capacities at reduced radii.
- Load ratings shown on the load rating charts are maximum allowable loads with the outriggers properly extended on a firm, level surface and the crane leveled and mounted on a factory recommended truck.
- Always level the crane with the level indicator located on the crane.
- The operator must reduce load to allow for factors such as wind, ground conditions, operating speeds and their effects on freely suspended loads.
- Overloading this crane may cause structural collapse or instability.
- Weights on any accessories attached to the boom or loadline must be deducted from the load chart capacities.
- Do not exceed jib capabilities at any reduced boom lengths.
- Do not deadhead lineblock against boom tip when extending boom or winching up.
- Keep at least three wraps of loadline on drum at all times.
- Use only specified cable with this machine.

**SERIES 1879
NO JIB/
FULL-SPAN
OUTRIGGER 24.7 ft**

Load Rating Chart: Series 1879 (24.08 m) Boom/Full-Span Outrigger 24.7 ft (7.6 m)

31 to 79 ft BOOM RATED LOADS

LOAD RADIUS (ft)	LOADED BOOM ANGLE	31 ft BOOM (lb)	LOADED BOOM ANGLE	47 ft BOOM (lb)	LOADED BOOM ANGLE	63 ft BOOM (lb)	LOADED BOOM ANGLE	79 ft BOOM (lb)
7	73.5	80,000						
8	71.5	74,000	78	50,000				
10	67.5	65,000	75.5	49,000				
12	63	57,000	73	45,000	77.5	40,000		
15	57	45,400	69	38,000	75	37,300	78.5	26,900
20	44.5	37,000	62.5	31,500	70.5	30,900	75	23,000
25	28	26,600	55.5	23,800	66	26,200	71	19,800
30			47	20,300	60.5	20,600	67.5	17,300
35			38.5	16,000	55	16,200	63	15,200
40			26.5	13,000	49	13,200	59	13,400
45					42.5	11,000	54.5	11,100
50					35	9,300	50	9,450
55					26	7,950	45	8,050
60					9.5	6,850	39.5	6,950
65							33	6,000
70							25	5,150
75							13	4,050
	0	21,300	0	10,900	0	6,700	0	3,800

NOTE:

1. All capacities are in pounds, angles in degrees, radius in feet.
2. Loaded boom angles are given as reference only.
3. Shaded areas are structurally limited capacities.

LOADLINE DEDUCT			
	Aux Boom Head	100 lb	(45 kg)
5 USt	Downhaul Weight	180 lb	(82 kg)
15 USt	1 Sheave Block	375 lb	(170 kg)
25 USt	2 Sheave Block	640 lb	(290 kg)
35 USt	3 Sheave Block	870 lb	(395 kg)
40 USt	4 Sheave Block	970 lb	(440 kg)

1800

THIS CHART IS ONLY A GUIDE AND SHOULD NOT BE USED TO OPERATE THE CRANE. The individual crane's load chart, operating instructions and other instructional plates must be read and understood prior to operating the crane.



capacities

Load Rating Chart: Series 1879 (24.08 m) Boom/Mid-Span Outrigger 17.5 ft (5.4 m)

National Crane will send you a chart on request – or you may secure needed load rating information through your nearest National Crane dealer.

6

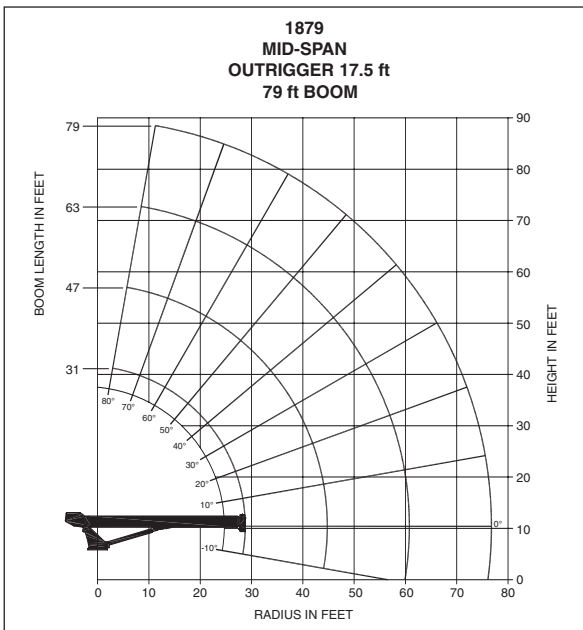

CAUTION:

- Do not operate crane booms, jib extensions, any accessories or loads within 10 ft (3m) of live power lines or other conductors of electricity.
- Jib and boom capacities shown are maximum for each section.
- Do not exceed capacities at reduced radii.
- Load ratings shown on the load rating charts are maximum allowable loads with the outriggers properly extended on a firm, level surface and the crane leveled and mounted on a factory recommended truck.
- Always level the crane with the level indicator located on the crane.
- The operator must reduce load to allow for factors such as wind, ground conditions, operating speeds and their effects on freely suspended loads.
- Overloading this crane may cause structural collapse or instability.
- Weights on any accessories attached to the boom or loadline must be deducted from the load chart capacities.
- Do not exceed jib capabilities at any reduced boom lengths.
- Do not deadhead lineblock against boom tip when extending boom or winching up.
- Keep at least three wraps of loadline on drum at all times.
- Use only specified cable with this machine.

Load Rating Chart: Series 1879 (24.08 m) Boom/Mid-Span Outrigger 17.5 ft (5.4 m)

31 TO 79 ft BOOM RATED LOADS

**SERIES 1879
NO JIB/
MID-SPAN
OUTRIGGER 17.5 ft**

NOTE:

1. All capacities are in pounds, angles in degrees, radius in feet.
2. Loaded boom angles are given as reference only.
3. Shaded areas are structurally limited capacities.

LOAD RADIUS (ft)	LOADED BOOM ANGLE	31 ft BOOM (lb)	LOADED BOOM ANGLE	47 ft BOOM (lb)	LOADED BOOM ANGLE	63 ft BOOM (lb)	LOADED BOOM ANGLE	79 ft BOOM (lb)
7	73.5	80,000						
8	71.5	74,000	78	50,000				
10	67.5	65,000	75.5	49,000				
12	63	57,000	73	45,000	77.5	40,000		
15	56.5	45,400	69	38,000	75	37,300	78.5	26,900
20	43.5	25,900	62.5	26,500	70	27,000	75	23,000
25	27.5	16,700	55	17,100	65.5	17,500	71	17,700
30			47	12,200	60	12,400	67	12,600
35			38	9,100	54.5	9,350	63	9,500
40			25.5	7,100	49	7,300	59	7,400
45					42	5,750	54.5	5,850
50					34.5	4,600	49.5	4,700
55					25.5	3,650	44.5	3,750
60					9	2,900	38.5	3,000
65							32.5	2,400
70							24.5	1,900
75							12.5	1,450
	0	12,800	0	5,600	0	2,800	0	1,300

THIS CHART IS ONLY A GUIDE AND SHOULD NOT BE USED TO OPERATE THE CRANE. The individual crane's load chart, operating instructions and other instructional plates must be read and understood prior to operating the crane.

1800

LOADLINE DEDUCT

Aux Boom Head	100 lb	(45 kg)
5 USt Downhaul Weight	180 lb	(82 kg)
15 USt 1 Sheave Block	375 lb	(170 kg)
25 USt 2 Sheave Block	640 lb	(290 kg)
35 USt 3 Sheave Block	870 lb	(395 kg)
40 USt 4 Sheave Block	970 lb	(440 kg)



capacities

Load Rating Chart: Series 18103 (31.39 m) Boom with 31-55 ft (9.45-16.76 m) Jib/Full-Span Outrigger 24.7 ft (7.6 m)

National Crane will send you a chart on request – or you may secure needed load rating information through your nearest National Crane dealer.

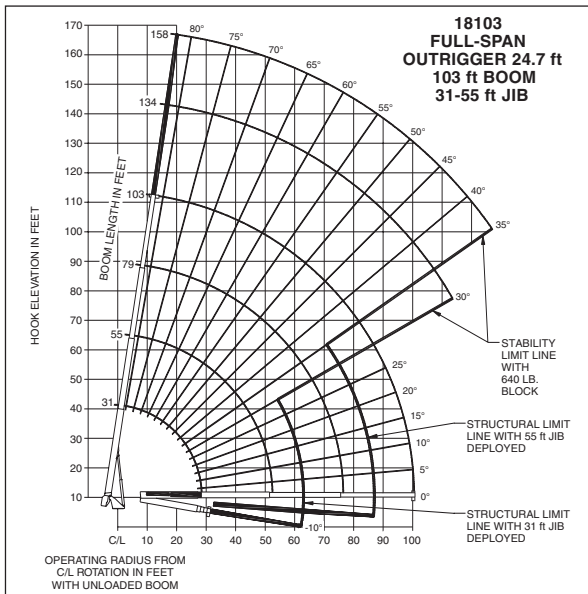

CAUTION:

- Do not operate crane booms, jib extensions, any accessories or loads within 10 ft (3m) of live power lines or other conductors of electricity.
- Jib and boom capacities shown are maximum for each section.
- Do not exceed capacities at reduced radii.
- Load ratings shown on the load rating charts are maximum allowable loads with the outriggers properly extended on a firm, level surface and the crane leveled and mounted on a factory recommended truck.
- Always level the crane with the level indicator located on the crane.
- The operator must reduce load to allow for factors such as wind, ground conditions, operating speeds and their effects on freely suspended loads.
- Overloading this crane may cause structural collapse or instability.
- Weights on any accessories attached to the boom or loadline must be deducted from the load chart capacities.
- Do not exceed jib capabilities at any reduced boom lengths.
- Do not deadhead lineblock against boom tip when extending boom or winching up.
- Keep at least three wraps of loadline on drum at all times.
- Use only specified cable with this machine.

7

Load Rating Chart: Series 18103 (31.39 m) Boom with 31-55 ft (9.45-16.76 m) Jib/Full-Span Outrigger 24.7 ft (7.6 m)

**SERIES 18103
WITH 31-55 ft JIB/
FULL-SPAN
OUTRIGGER 24.7 ft**

NOTE:

1. Operate with jib by radius when main boom is fully extended. If necessary increase boom angle to maintain loaded radius.
2. Operate with jib by boom angle when main boom is not fully extended. Do not exceed rated jib capacities at any reduced boom lengths.
3. Capacities do not exceed 85% stability.
4. Shaded areas are structurally limited capacities.

NOTE:

1. All capacities are in pounds, angles in degrees, radius in feet.
2. Loaded boom angles are given as reference only.
3. Shaded areas are structurally limited capacities.

LOADLINE DEDUCT		
Aux Boom Head	100 lb	(45 kg)
5 Ust Downhaul Weight	180 lb	(82 kg)
15 Ust 1 Sheave Block	375 lb	(170 kg)
25 Ust 2 Sheave Block	640 lb	(290 kg)
35 Ust 3 Sheave Block	870 lb	(395 kg)
40 Ust 4 Sheave Block	970 lb	(440 kg)

31 TO 103 ft BOOM RATED LOADS WITHOUT JIB									31 ft JIB RATED LOADS		
LOAD RADIUS (ft)	LOADED BOOM ANGLE	31 FT BOOM (lb)	LOADED BOOM ANGLE	55 FT BOOM (lb)	LOADED BOOM ANGLE	79 FT BOOM (lb)	LOADED BOOM ANGLE	103 FT BOOM (lb)	RADIUS FULLY EXTENDED	LOADED BOOM ANGLE	RATED LOADS ALL BOOM LENGTHS
7	73.9	80,000							25	80	8,800
8	71.9	74,000							38	75	8,000
10	67.7	65,000	78.9	50,000					49	70	6,500
12	63.5	57,000	76.6	45,000					60	65	5,100
15	56.7	44,000	73.3	38,000	79.6	30,000			70	60	4,100
20	44.1	30,800	67.7	31,500	75.9	26,000	79.5	17,000	79	55	3,300
25	27.4	23,200	61.7	23,800	72.1	22,000	76.7	15,200	88	50	2,600
30			55.3	18,800	68.1	18,500	73.8	13,500	96	45	1,900
35			48.3	15,200	64	15,500	70.9	12,000	103	40	1,350
40			40.5	12,500	59.6	12,800	67.8	10,500	110	35	950
45			31.2	10,500	55.1	10,700	65	9,300	115	30	650
50			19.3	9,000	50.7	9,000	61.8	8,300			
55					45.5	7,600	58.5	7,400			
60					39.9	6,600	55.1	6,500			
65					33.4	5,600	51.4	5,600			
70					25.5	4,800	47.5	4,800			
75					13.4	4,050	43.4	4,100			
80						38.9	3,500				
85							33.8	2,950			
90							28	2,450			
95							20.7	2,050			
100							7.9	1,650			
0		19,700	0	8,200	0	3,800	0	1,600			

55 ft JIB RATED LOADS		
RADIUS FULLY EXTENDED	LOADED BOOM ANGLE	RATED LOADS ALL BOOM LENGTHS
29	80	4,000
45	75	3,700
59	70	3,300
73	65	3,000
85	60	2,600
96	55	2,100
106	50	1,700
115	45	1,300
123	40	950
130	35	650

RATED LOAD REDUCTIONS WITH JIB		
BOOM LENGTH	31-55 ft JIB STOWED	31-55 ft JIB ERRECTED AT 31 ft LENGTH
	31 ft	Reduce load 800 lb
55 ft	Reduce load 450 lb	Reduce load 2,000 lb
79 ft	Reduce load 350 lb	Reduce load 1,900 lb
103 ft	Reduce load 250 lb	Reduce load 1,800 lb

THIS CHART IS ONLY A GUIDE AND SHOULD NOT BE USED TO OPERATE THE CRANE. The individual crane's load chart, operating instructions and other instructional plates must be read and understood prior to operating the crane.

1800



capacities

Load Rating Chart: Series 18103 (31.39 m) Boom with 31-55 ft (9.45-16.76 m) Jib/Mid-Span Outrigger 17.5 ft (5.4 m)

National Crane will send you a chart on request – or you may secure needed load rating information through your nearest National Crane dealer.

8

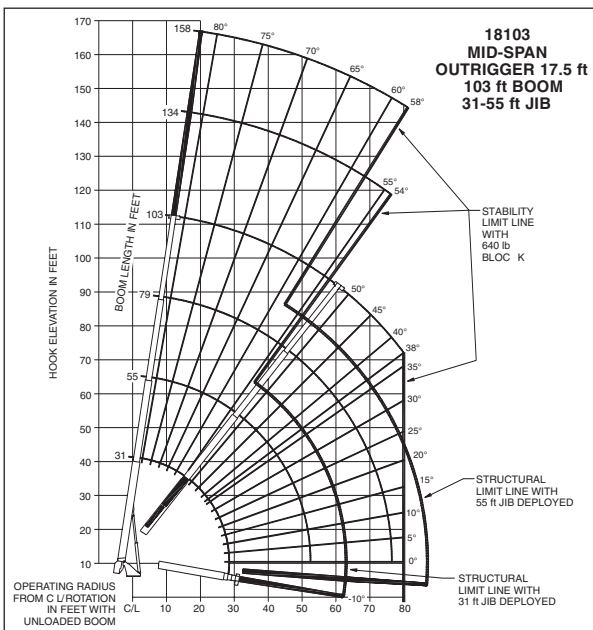

CAUTION:

- Do not operate crane booms, jib extensions, any accessories or loads within 10 ft (3m) of live power lines or other conductors of electricity.
- Jib and boom capacities shown are maximum for each section.
- Do not exceed capacities at reduced radii.
- Load ratings shown on the load rating charts are maximum allowable loads with the outriggers properly extended on a firm, level surface and the crane leveled and mounted on a factory recommended truck.
- Always level the crane with the level indicator located on the crane.
- The operator must reduce load to allow for factors such as wind, ground conditions, operating speeds and their effects on freely suspended loads.
- Overloading this crane may cause structural collapse or instability.
- Weights on any accessories attached to the boom or loadline must be deducted from the load chart capacities.
- Do not exceed jib capabilities at any reduced boom lengths.
- Do not deadhead lineblock against boom tip when extending boom or winching up.
- Keep at least three wraps of loadline on drum at all times.
- Use only specified cable with this machine.

Load Rating Chart: Series 18103 (31.39 m) Boom with 31-55 ft (9.45-16.76 m) Jib/Mid-Span Outrigger 17.5 ft (5.4 m)

SERIES 18103 WITH 31-55 ft JIB MID-SPAN OUTRIGGER 17.5 ft

- NOTE:
1. Operate with jib by radius when main boom is fully extended. If necessary increase boom angle to maintain loaded radius.
 2. Operate with jib by boom angle when main boom is not fully extended. Do not exceed rated jib capacities at any reduced boom lengths.
 3. Capacities do not exceed 85% stability.
 4. Shaded areas are structurally limited capacities.

- NOTE:
1. All capacities are in pounds, angles in degrees, radius in feet.
 2. Loaded boom angles are given as reference only.
 3. Shaded areas are structurally limited capacities.

LOADLINE DEDUCT

Aux Boom Head	100 lb	(45 kg)
5 USt Downhaul Weight	180 lb	(82 kg)
15 USt 1 Sheave Block	375 lb	(170 kg)
25 USt 2 Sheave Block	640 lb	(290 kg)
35 USt 3 Sheave Block	870 lb	(395 kg)
40 USt 4 Sheave Block	970 lb	(440 kg)

31 TO 103 ft BOOM RATED LOADS WITHOUT JIB

LOAD RADIUS (ft)	LOADED BOOM ANGLE	31 ft BOOM (lb)	LOADED BOOM ANGLE	55 ft BOOM (lb)	LOADED BOOM ANGLE	79 ft BOOM (lb)	LOADED BOOM ANGLE	103 ft BOOM (lb)
7	73.9	80,000						
8	71.9	74,000						
10	67.7	65,000	78.9	50,000				
12	63.4	57,000	76.6	45,000				
15	56.7	44,000	73.3	38,000	79.6	30,000		
20	44	26,000	67.5	27,000	75.9	26,000	79.5	17,000
25	27.4	16,700	61.3	17,500	71.6	17,500	76.7	15,200
30			54.8	12,300	67.5	12,300	73.7	12,200
35			48.5	9,200	63.6	9,300	70.7	9,400
40			40.8	7,000	59.2	7,100	67.5	7,200
45			31.6	5,400	54.7	5,500	64.2	5,600
50			18.6	4,150	49.9	4,300	60.9	4,350
55					44.8	3,300	57.5	3,350
60					39.1	2,550	54.1	2,600
65					32.7	1,900	50.3	1,950
70					24.8	1,350	46.5	1,400
75					12.7	950	42.4	1,000
80							37.9	650
0		13,200	0	3,600	0	800		

31 ft JIB RATED LOADS

RADIUS FULLY EXTENDED	LOADED BOOM ANGLE	RATED LOADS ALL BOOM LENGTHS
25	80	8,800
38	75	8,000
48	70	5,000
57	65	3,000
67	60	1,650
76	55	750
78	54	650

55 ft JIB RATED LOADS

RADIUS FULLY EXTENDED	LOADED BOOM ANGLE	RATED LOADS ALL BOOM LENGTHS
29	80	4,000
45	75	3,700
59	70	3,300
70	65	2,150
80	60	1,150
85	58	650

RATED LOAD REDUCTIONS WITH JIB

BOOM LENGTH	31-55 ft JIB STOWED	31-55 ft JIB ERECTED AT 31 ft LENGTH
31 ft	Reduce load 800 lb	Reduce load 2,300 lb
55 ft	Reduce load 450 lb	Reduce load 2,000 lb
79 ft	Reduce load 350 lb	Reduce load 1,900 lb
103 ft	Reduce load 250 lb	Reduce load 1,800 lb

1800

THIS CHART IS ONLY A GUIDE AND SHOULD NOT BE USED TO OPERATE THE CRANE. The individual crane's load chart, operating instructions and other instructional plates must be read and understood prior to operating the crane.



capacities

Load Rating Chart: Series 18127 (38.71 m) Boom with 31-55 ft (9.45-16.76 m) Jib/Full-Span Outrigger 24.7 ft (7.6 m)

National Crane will send you a chart on request – or you may secure needed load rating information through your nearest National Crane dealer.

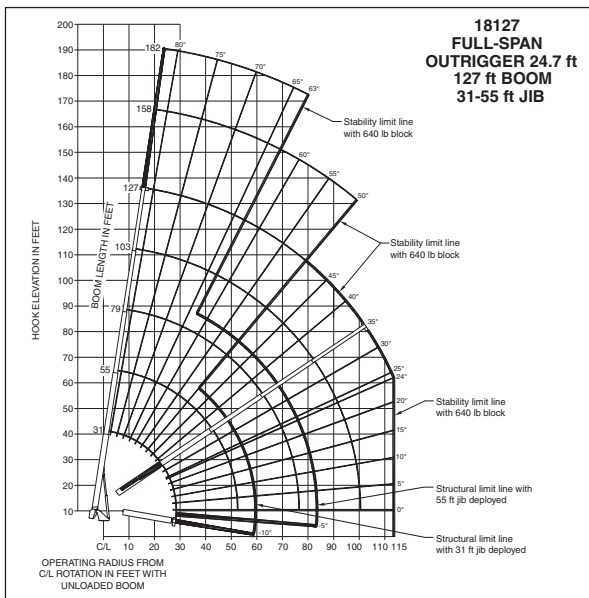

CAUTION:

- Do not operate crane booms, jib extensions, any accessories or loads within 10 ft (3m) of live power lines or other conductors of electricity.
- Jib and boom capacities shown are maximum for each section.
- Do not exceed capacities at reduced radii.
- Load ratings shown on the load rating charts are maximum allowable loads with the outriggers properly extended on a firm, level surface and the crane leveled and mounted on a factory recommended truck.
- Always level the crane with the level indicator located on the crane.
- The operator must reduce load to allow for factors such as wind, ground conditions, operating speeds and their effects on freely suspended loads.
- Overloading this crane may cause structural collapse or instability.
- Weights on any accessories attached to the boom or loadline must be deducted from the load chart capacities.
- Do not exceed jib capabilities at any reduced boom lengths.
- Do not deadhead lineblock against boom tip when extending boom or winching up.
- Keep at least three wraps of loadline on drum at all times.
- Use only specified cable with this machine.

9

Load Rating Chart: Series 18127 (38.71 m) Boom with 31-55 ft (9.45-16.76 m) Jib/Full-Span Outrigger 24.7 ft (7.6 m)

**SERIES 18127 WITH
31-55 ft JIB/
FULL-SPAN
OUTRIGGER 24.7 ft**

31 TO 127 ft BOOM RATED LOADS WITHOUT JIB

LOAD RADIUS (ft)	LOADED BOOM ANGLE	31 ft BOOM (lb)	LOADED BOOM ANGLE	55 ft BOOM (lb)	LOADED BOOM ANGLE	79 ft BOOM (lb)	LOADED BOOM ANGLE	103 ft BOOM (lb)	LOADED BOOM ANGLE	127 ft BOOM (lb)	
7	74.5	80,000									
8	72.4	74,000									
10	68.2	64,000									
12	63.8	56,000	76.9	40,000							
15	56.9	43,000	73.8	38,000	79.8	29,000					
20	44.2	30,000	68.1	31,000	76.2	25,000	80	16,000			
25	27.4	22,500	62	23,400	72.5	21,500	77.2	14,500	80	10,000	
30			55.5	18,300	68.5	18,700	74.4	13,000	78	9,500	
35			48.6	14,800	64.3	15,100	71.5	11,500	75.9	9,000	
40			40.7	12,100	59.9	12,500	68.6	10,500	73.6	8,100	
45			31.3	10,100	55.3	10,400	65.9	9,500	71.2	7,200	
50			19.4	8,500	50.9	8,800	62.7	8,500	68.8	6,500	
55					45.8	7,500	59.3	7,500	66.3	5,800	
60					40.1	6,400	55.7	6,500	63.7	5,300	
65					33.6	5,400	52	5,600	61.1	4,800	
70					25.6	4,600	48.1	4,700	58.4	4,300	
75						13.5	3,850	43.9	3,950	55.6	3,900
80								39.3	3,350	52.6	3,400
85								34.3	2,800	49.4	2,850
90								28.4	2,300	46	2,350
95								21	1,850	42.5	1,900
100								8.2	1,500	38.8	1,550
105										34.6	1,200
110										30	900
115										24.6	650
	0	19,000	0	7,700	0	3,600	0	1,450			

NOTE:

1. Operate with jib by radius when main boom is fully extended. If necessary increase boom angle to maintain loaded radius.
2. Operate with jib by boom angle when main boom is not fully extended. Do not exceed rated jib capacities at any reduced boom lengths.
3. Capacities do not exceed 85% stability.
4. Shaded areas are structurally limited capacities.

NOTE:

1. All capacities are in pounds, angles in degrees, radius in feet.
2. Loaded boom angles are given as reference only.
3. Shaded areas are structurally limited capacities.

LOADLINE DEDUCT		
	Aux Boom Head	100 lb (45 kg)
5 USt	Downhaul Weight	180 lb (82 kg)
15 USt	1 Sheave Block	375 lb (170 kg)
25 USt	2 Sheave Block	640 lb (290 kg)
35 USt	3 Sheave Block	870 lb (395 kg)
40 USt	4 Sheave Block	970 lb (440 kg)

31 ft JIB RATED LOADS		
RADIUS FULLY EXTENDED	LOADED BOOM ANGLE	RATED LOADS ALL BOOM LENGTHS
30	80	3,400
46	75	3,200
60	70	2,700
73	65	2,100
85	60	1,700
96	55	1,200
106	50	650

55 ft JIB RATED LOADS		
RADIUS FULLY EXTENDED	LOADED BOOM ANGLE	RATED LOADS ALL BOOM LENGTHS
36	80	2,200
54	75	2,200
70	70	1,600
85	65	1,000

RATED LOAD REDUCTIONS WITH JIB		
BOOM LENGTH	31 ft JIB STOWED	31-55 ft JIB ERRECTED AT 31 ft LENGTH
31 ft	Reduce load 800 lb	Reduce load 2,300 lb
55 ft	Reduce load 450 lb	Reduce load 2,000 lb
79 ft	Reduce load 350 lb	Reduce load 1,900 lb
103 ft	Reduce load 250 lb	Reduce load 1,800 lb
127 ft	Reduce load 200 lb	Reduce load 1,700 lb

THIS CHART IS ONLY A GUIDE AND SHOULD NOT BE USED TO OPERATE THE CRANE. The individual crane's load chart, operating instructions and other instructional plates must be read and understood prior to operating the crane.

1800



capacities

Load Rating Chart: Series 18142 (43.29 m) Boom with 26 ft (7.9 m) Jib/Full-Span Outrigger 24.7 ft (7.6 m)

National Crane will send you a chart on request – or you may secure needed load rating information through your nearest National Crane dealer.

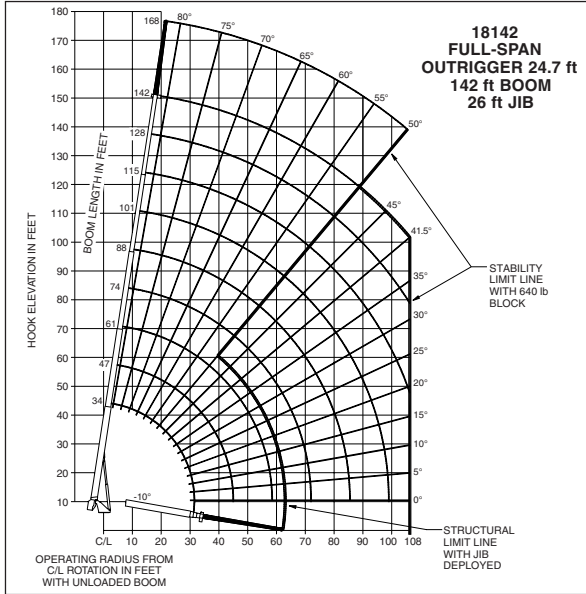

CAUTION:

- Do not operate crane booms, jib extensions, any accessories or loads within 10 ft (3m) of live power lines or other conductors of electricity.
- Jib and boom capacities shown are maximum for each section.
- Do not exceed capacities at reduced radii.
- Load ratings shown on the load rating charts are maximum allowable loads with the outriggers properly extended on a firm, level surface and the crane leveled and mounted on a factory recommended truck.
- Always level the crane with the level indicator located on the crane.
- The operator must reduce load to allow for factors such as wind, ground conditions, operating speeds and their effects on freely suspended loads.
- Overloading this crane may cause structural collapse or instability.
- Weights on any accessories attached to the boom or loadline must be deducted from the load chart capacities.
- Do not exceed jib capabilities at any reduced boom lengths.
- Do not deadhead lineblock against boom tip when extending boom or winching up.
- Keep at least three wraps of loadline on drum at all times.
- Use only specified cable with this machine.

11

Load Rating Chart: Series 18142 (43.29 m) Boom with 26 ft (7.9 m) Jib/Full-Span Outrigger 24.7 ft (7.6 m)

SERIES 18142 WITH 26 ft JIB/ FULL-SPAN OUTRIGGER 24.7 ft

NOTE:

1. Operate with jib by radius when main boom is fully extended. If necessary increase boom angle to maintain loaded radius.
2. Operate with jib by boom angle when main boom is not fully extended. Do not exceed rated jib capacities at any reduced boom lengths.
3. Capacities do not exceed 85% stability.
4. Shaded areas are structurally limited capacities.

NOTE:

1. All capacities are in pounds, angles in degrees, radius in feet.
2. Loaded boom angles are given as reference only.
3. Shaded areas are structurally limited capacities.

34 ft BOOM			47 ft BOOM			61 ft BOOM			74 ft BOOM					
Radius	Angle	Capacity	Radius	Angle	Capacity	Radius	Angle	Capacity	Radius	Angle	Capacity			
7	76.3	80,000												
8	74.3	74,000												
10	70.5	63,000	10	76.6	40,000									
12	66.7	55,000	12	74.2	40,000	12	78.7	40,000						
15	60.6	43,000	15	70.5	40,000	15	75.8	36,000	15	79.2	32,000			
20	49.6	29,700	20	63.6	30,600	20	70.8	30,000	20	75.2	26,600			
25	36.4	22,000	25	56.2	22,800	25	65.4	23,000	25	71	21,500			
30	16.2	17,000	30	48.1	17,700	30	59.8	17,900	30	66.6	17,400			
	0	15,800	35	39.9	14,100	35	53.8	14,300	35	62.1	14,400			
			40	27.1	11,400	40	47.4	11,600	40	57.4	11,800			
				0	9,400	45	40.9	9,700	45	52.9	9,900			
						50	32.6	8,000	50	47.6	8,200			
						55	21.5	6,800	55	41.7	6,900			
							0	5,900	60	35.1	5,700			
									65	27.1	4,850			
									70	15.4	4,000			
										0	3,800			
88 ft BOOM			101 ft BOOM			115 ft BOOM			128 ft BOOM			142 ft BOOM		
Radius	Angle	Capacity	Radius	Angle	Capacity	Radius	Angle	Capacity	Radius	Angle	Capacity	Radius	Angle	Capacity
20	78.2	23,000	20	79.9	17,000									
25	74.9	20,000	25	77.2	15,800	25	79.1	13,000						
30	71.3	17,000	30	74.4	14,200	30	76.7	11,900	30	78.5	9,500	30	79.7	8,000
35	67.7	14,600	35	71.5	12,700	35	74.2	10,900	35	76.5	9,000	35	77.8	7,500
40	63.8	11,900	40	68.3	10,800	40	71.9	9,800	40	74.4	8,500	40	75.9	7,000
45	60.3	10,000	45	65.4	9,500	45	69.3	9,000	45	72.1	7,800	45	73.9	6,400
50	56.2	8,300	50	62.1	8,200	50	66.5	8,000	50	69.6	7,000	50	71.8	5,800
55	51.9	7,000	55	58.6	7,000	55	63.6	7,100	55	67.1	6,200	55	69.5	5,200
60	47.3	5,800	60	54.9	5,800	60	60.5	5,900	60	64.4	5,300	60	67.3	4,700
65	42.3	4,900	65	51.1	4,950	65	57.3	5,000	65	61.7	4,600	65	65	4,200
70	36.8	4,100	70	47.1	4,150	70	54	4,200	70	59	4,000	70	62.7	3,750
75	30.5	3,400	75	42.7	3,450	75	50.5	3,500	75	56.2	3,400	75	60.2	3,300
80	22.5	2,800	80	38.1	2,850	80	46.9	2,900	80	53.2	2,900	80	57.8	2,950
85	8.6	2,300	85	32.8	2,300	85	43.1	2,350	85	50	2,350	85	55.1	2,400
	0	2,200	90	26.5	1,850	90	39	1,900	90	46.8	1,900	90	52.3	1,950
			95	18.3	1,450	95	34.4	1,500	95	43.3	1,500	95	49.4	1,500
				0	1,100	100	29.3	1,100	100	39.6	1,100	100	46.5	1,150
						105	23	750	105	35.7	800	105	43.4	800
						108	18.3	650	108	33.1	650	108	41.5	650
RATED LOAD REDUCTIONS WITH JIB														
BOOM LENGTH	26 ft JIB STOWED		26 ft JIB ERRECTED		26 ft JIB RATED LOADS									
	Radius	Capacity	Radius	Capacity	Radius Fully Extended	Loaded Boom Angle	Rated Loads All Boom Lengths							
34 ft		Reduce load 525 lb		Reduce load 1,050 lb	33	80	4,000							
47 ft		Reduce load 400 lb		Reduce load 1,000 lb	50	75	3,800							
61 ft		Reduce load 300 lb		Reduce load 950 lb	65	70	3,200							
74 ft		Reduce load 250 lb		Reduce load 925 lb	78	65	2,450							
88 ft		Reduce load 200 lb		Reduce load 900 lb	90	60	1,800							
101 ft		Reduce load 150 lb		Reduce load 900 lb	101	55	1,250							
115 ft		Reduce load 150 lb		Reduce load 875 lb	112	50	650							
128 ft		Reduce load 150 lb		Reduce load 875 lb										
142 ft		Reduce load 125 lb		Reduce load 850 lb										

THIS CHART IS ONLY A GUIDE AND SHOULD NOT BE USED TO OPERATE THE CRANE. The individual crane's load chart, operating instructions and other instructional plates must be read and understood prior to operating the crane.

1800



capacities

Load Rating Chart: Series 18142 (43.29 m) Boom with 26 ft (7.9 m) Jib/Mid-Span Outrigger 17.5 ft (5.4 m)

12

National Crane will send you a chart on request – or you may secure needed load rating information through your nearest National Crane dealer.

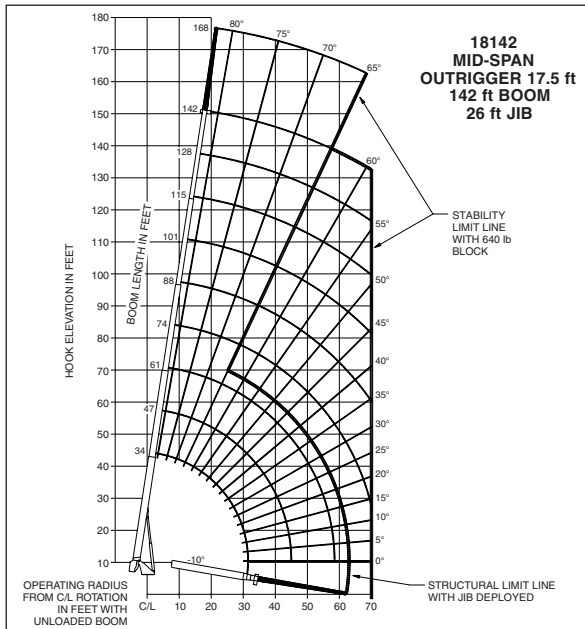

CAUTION:

- Do not operate crane booms, jib extensions, any accessories or loads within 10 ft (3m) of live power lines or other conductors of electricity.
- Jib and boom capacities shown are maximum for each section.
- Do not exceed capacities at reduced radii.
- Load ratings shown on the load rating charts are maximum allowable loads with the outriggers properly extended on a firm, level surface and the crane leveled and mounted on a factory recommended truck.
- Always level the crane with the level indicator located on the crane.
- The operator must reduce load to allow for factors such as wind, ground conditions, operating speeds and their effects on freely suspended loads.
- Overloading this crane may cause structural collapse or instability.
- Weights on any accessories attached to the boom or loadline must be deducted from the load chart capacities.
- Do not exceed jib capabilities at any reduced boom lengths.
- Do not deadhead lineblock against boom tip when extending boom or winching up.
- Keep at least three wraps of loadline on drum at all times.
- Use only specified cable with this machine.

Load Rating Chart: Series 18142 (43.29 m) Boom with 26 ft (7.9 m) Jib/Mid-Span Outrigger 17.5 ft (5.4 m)

SERIES 18142 WITH 26 ft JIB/ MID-SPAN OUTRIGGER 17.5 ft

NOTE:

1. Operate with jib by radius when main boom is fully extended. If necessary increase boom angle to maintain loaded radius.
2. Operate with jib by boom angle when main boom is not fully extended. Do not exceed rated jib capacities at any reduced boom lengths.
3. Capacities do not exceed 85% stability.
4. Shaded areas are structurally limited capacities.

NOTE:

1. All capacities are in pounds, angles in degrees, radius in feet.
2. Loaded boom angles are given as reference only.
3. Shaded areas are structurally limited capacities.

LOADLINE DEDUCT

Aux Boom Head	100 lb	(45 kg)
Downhaul Weight	180 lb	(82 kg)
15 USt	1 Sheave Block	375 lb (170 kg)
25 USt	2 Sheave Block	640 lb (290 kg)
35 USt	3 Sheave Block	870 lb (395 kg)
40 USt	4 Sheave Block	970 lb (440 kg)

34 ft BOOM			47 ft BOOM			61 ft BOOM			74 ft BOOM		
Radius	Angle	Capacity	Radius	Angle	Capacity	Radius	Angle	Capacity	Radius	Angle	Capacity
7	76.3	80,000									
8	74.3	74,000									
10	70.5	63,000	10	76.6	40,000						
12	66.7	55,000	12	74.2	40,000	12	78.7	40,000			
15	60.6	43,000	15	70.5	40,000	15	75.8	36,000	15	79.2	32,000
20	49.5	25,400	20	63.6	26,400	20	70.6	26,500	20	75.2	26,600
25	36.3	15,900	25	55.9	16,700	25	65	17,000	25	70.5	17,100
30	16.2	10,700	30	47.8	11,500	30	59.3	11,800	30	65.9	11,900
	0	9,500	35	39.4	8,300	35	53.9	8,600	35	61.8	8,700
			40	27.9	6,000	40	47.4	6,300	40	57	6,400
				0	4,300	45	40.3	4,600	45	52	4,800
						50	31.9	3,400	50	46.7	3,600
						55	20.7	2,400	55	40.9	2,600
							0	1,750	60	34.3	1,800
									65	26.2	1,100
									70	14.5	650

88 ft BOOM			101 ft BOOM			115 ft BOOM			128 ft BOOM			142 ft BOOM		
Radius	Angle	Capacity	Radius	Angle	Capacity	Radius	Angle	Capacity	Radius	Angle	Capacity	Radius	Angle	Capacity
20	78.2	23,000	20	79.9	17,000									
25	74.4	17,200	25	77.2	15,800	25	79.1	13,000						
30	70.5	12,000	30	74	12,100	30	76.7	11,900	30	78.5	9,500	30	79.7	8,000
35	67	8,800	35	70.9	8,900	35	74	9,000	35	76.5	9,000	35	77.8	7,500
40	63.1	6,500	40	67.6	6,600	40	71	6,700	40	73.6	6,700	40	75.7	6,700
45	59.2	4,950	45	64.3	5,100	45	68	5,200	45	71	5,200	45	73.3	5,200
50	55.1	3,700	50	60.8	3,800	50	65	3,900	50	68.3	3,900	50	70.8	3,900
55	50.8	2,700	55	57.3	2,800	55	62	2,900	55	65.6	2,900	55	68.4	2,900
60	46.2	1,900	60	53.7	2,000	60	59	2,100	60	62.9	2,100	60	66	2,100
65	41.3	1,200	65	49.9	1,300	65	55.8	1,400	65	60.2	1,400	65	63.5	1,400
70	35.8	700	70	45.9	750	70	52.6	800	70	57.4	800	70	61	800

RATED LOAD REDUCTIONS WITH JIB

BOOM LENGTH	26 ft JIB STOWED		26 ft JIB ERECTED		26 ft JIB RATED LOADS		
	Reduce load	Capacity	Reduce load	Capacity	Radius Fully Extended	Loaded Boom Angle	Rated Loads All Boom Lengths
34 ft	Reduce load	525 lb	Reduce load	1,050 lb	33	80	4,000
47 ft	Reduce load	400 lb	Reduce load	1,000 lb	50	75	3,800
61 ft	Reduce load	300 lb	Reduce load	950 lb	62	70	2,100
74 ft	Reduce load	250 lb	Reduce load	925 lb	74	65	750
88 ft	Reduce load	200 lb	Reduce load	900 lb			
101 ft	Reduce load	200 lb	Reduce load	900 lb			
115 ft	Reduce load	150 lb	Reduce load	875 lb			
126 ft	Reduce load	150 lb	Reduce load	875 lb			
142 ft	Reduce load	125 lb	Reduce load	850 lb			

THIS CHART IS ONLY A GUIDE AND SHOULD NOT BE USED TO OPERATE THE CRANE. The individual crane's load chart, operating instructions and other instructional plates must be read and understood prior to operating the crane.

1800



accessories

13

Radio Remote Controls – (Ground level or boom tip)

Eliminate the handling and maintenance concerns that accompany cabled remotes. Operate to a range of about 250 ft (76 m), varying with conditions.

- **NB4R** (R4 functions)

One-Person Basket –

Strong but lightweight steel basket with 300 lb. (139 kg) capacity, gravity hung with swing lock and full body harness.

- **B1-S**
- **2B1-S** (for dual locking baskets)

Heavy-duty Personnel Basket –

1,200 lb (544 kg) capacity steel basket with safety loops for four passengers. Gravity leveling 72 x 42 in (183 x 107cm) platform. Fast attachment and secure locking systems.

- **BSA-1**
- **BSA-R1** (provides rotation)

Air Conditioning for Crane Cab –

(Requires larger truck alternator) Provides excellent crane cab cooling to overcome the radiant heat from the sun reflection.

- **A/C**

Auxiliary Winch 10,000 lb. Line Pull –

Second winch redundant to the main, planetary winch with boom tip “rooster sheave” to allow reeving of both winch lines.

- **18AW**

Work Lights –

- Amber flashing beacon mounted on crane cab
- Capacity indicator light outside of cab for visual display of load on hook versus capacity
- Spotlight mounted on cab, manually adjusted from the crane cab
- Worklight on boom, switch and wiring in-cab to operate customer supplied worklight (without remote controls)
- Worklight in fixed position on crane cab with in cab power
- Worklight adjustable from crane with in-cab power

- **ABR**

- **CIE**
- **MSL**

- **WLB**
- **WLF**
- **WLR**

Winch Drum Rotation Indicator –

Winch drum rotation indicator on winch control lever.

Winch drum rotation indicator in cab (for use with standard and auxiliary winches).

- **WDRI-1**
- **WDRI-2**

Hour Meter –

Hour meter in truck cab to record crane operation hours.

- **HRM**

Steel Tool Box Options

Spanish-Language Danger Decals, Control Knobs, and Operators' Manuals

- **SDD**
- **SOM**

1800



dimensions specifications

Dimensions Specifications

14

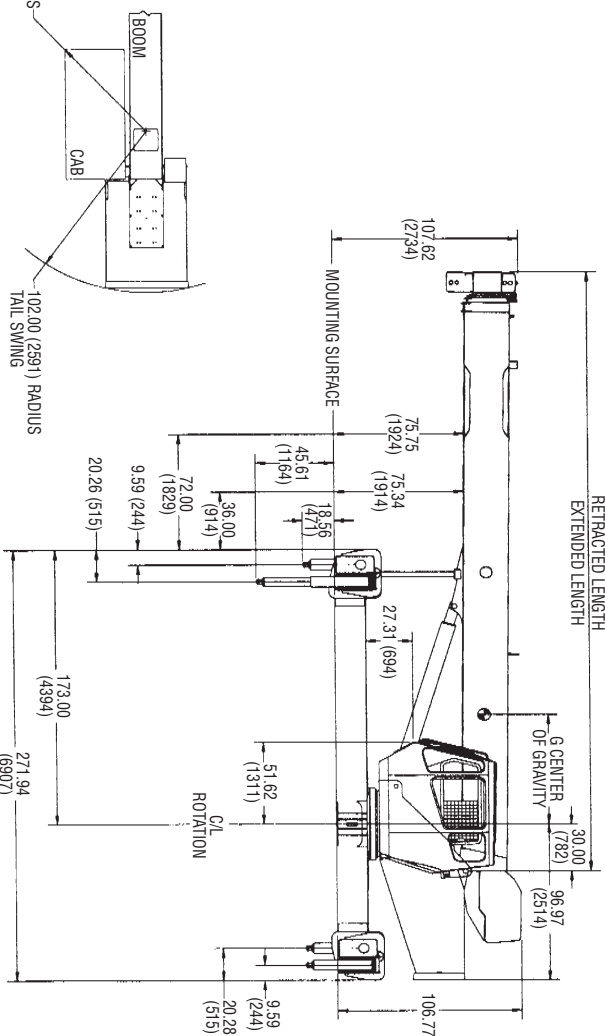
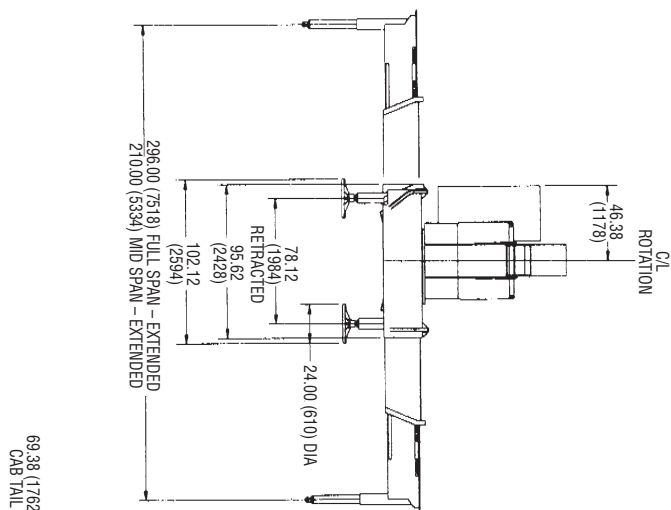

SERIES	RETRACTED LENGTH	EXTENDED LENGTH	G	WEIGHT WITH OIL*
18103	31 ft (9.45 m)	103 ft (31.40 m)	69 in (1.75 m)	33,850 lb (15,354 kg)
18127	31 ft (9.45 m)	127 ft (38.72 m)	69 in (1.75 m)	35,275 lb (16,000 kg)
18142	34 ft (10.36 m)	142 ft (43.28 m)	87 in (2.21 m)	36,970 lb (16,769 kg)
1879	31 ft (9.45 m)	79 ft (24.08 m)	69 in (1.75 m)	31,815 lb (14,431 kg)

*WEIGHT INCLUDES ALL ITEMS INCLUDING COMPLETE HO OUTRIGGERS, 2300 lb COUNTERWEIGHT, 375-lb BLOCK, DECKS AND SFO. BOOMS FULLY RETRACTED.

0081



notes**15****1800**



Regional Headquarters

Americas

Manitowoc, Wisconsin, USA

Tel: +1 920 684 6621
Fax: +1 920 683 6278

Shady Grove, Pennsylvania, USA

Tel: +1 717 597 8121
Fax: +1 717 597 4062

Regional Offices

Americas

Brazil

Alphaville
Tel: +55 11 4688 2716
Fax: +55 11 4191 1471

Mexico

Monterrey
Tel: +52 81 8124 0128
Fax: +52 81 8124 0129

Europe, Middle East, Africa

Algeria

Hydra
Tel: +21 3 21 48 1173
Fax: +21 3 21 48 1454

Czech Republic

Netvorice
Tel: +420 317 78 9313
Fax: +420 317 78 9314

France

Baudemont
Tel: +33 385 28 2589
Fax: +33 385 28 0430

Cergy

Tel: +33 130 31 3150
Fax: +33 130 38 6085

Decines

Tel: +33 472 81 5000
Fax: +33 472 81 5010

Germany

Langenfeld
Tel: +49 21 73 8909-0
Fax: +49 21 73 8909 30

Hungary

Budapest
Tel: +36 13 39 8622
Fax: +36 13 39 8622

Italy

Parabiago
Tel: +390 331 49 3311
Fax: +390 331 49 3330

Europe, Middle East, Africa

Ecully, France

Tel: +33 472 18 2020
Fax: +33 472 18 2000

Netherlands

Breda
Tel: +31 76 578 3999
Fax: +31 76 578 3978

Poland

Warsaw
Tel: +48 22 843 3824
Fax: +48 22 843 3471

Portugal

Alfena
Tel: +351 229 69 8840
Fax: +351 229 69 8848

Lisbon

Tel: +351 212 109 340
Fax: +351 212 109 349

Russia

Moscow
Tel: +7 495 641 2359
Fax: +7 495 641 2358

U.A.E.

Dubai
Tel: +971 4 3381 861
Fax: +971 4 3382 343

U. K.

Middlesex
Tel: +44 1 895 43 0053
Fax: +44 1 895 45 9500

Sunderland

Tel: +44 191 522 2000
Fax: +44 191 522 2052

Asia – Pacific

Australia

Melbourne
Tel: +61 3 9 336 1300
Fax: +61 3 9 336 1322

Sydney

Tel: +61 2 9 896 4433
Fax: +61 2 9 896 3122

Asia – Pacific

Shanghai, China

Tel: +86 21 51113579
Fax: +86 21 51113578

Singapore

Tel: +65 6264 1188
Fax: +65 6862 4142

China

Beijing
Tel: +86 10 58674761
Fax: +86 10 58674760

Xi'an

Tel: +86 29 87891465
Fax: +86 29 87884504

Korea

Seoul
Tel: +82 2 3439 0400
Fax: +82 2 3439 0405

Philippines

Makati City
Tel: +63 2 844 9437
Fax: +63 2 844 4712

Factories

U.S.A.

Manitowoc
Shady Grove

Brazil

Alphaville

France

Charlieu
La Clayette
Moulines

India

Calcutta
Puna

Italy

Niella Tanaro

Germany

Wilhelmshaven

Portugal

Fânzeres

China

Zhangjiagang

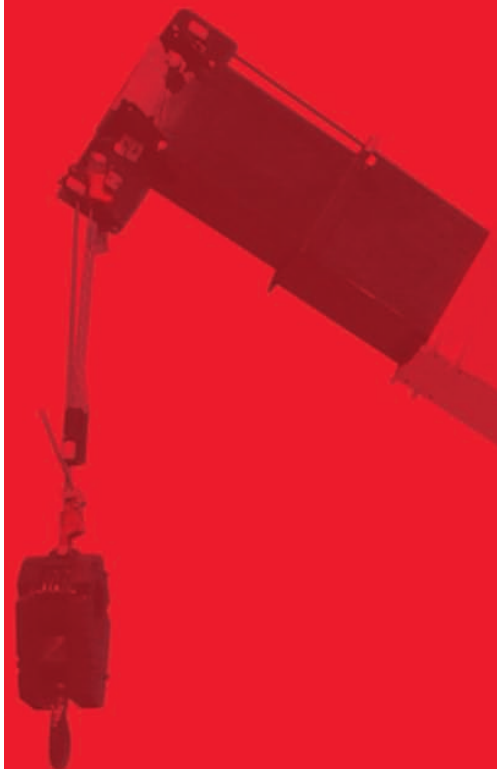

Constant improvement and engineering progress make it necessary that we reserve the right to make specification, equipment and price changes without notice. Illustrations shown may include optional equipment and accessories, and may not include all standard equipment.

©2007 MANITOWOC

Printed in USA

Form No. 1800

0907 / 2M



www.manitowoccrane.com

