

Grove Maniowoc National Crane Potain



National Crane 500E2 Series

Product Guide



Features

- 16,3 t (18 USt) rating
- 21,6 m (71 ft) three-section boom
- Self-lubricating Easy Glide wear pads
- Internal anti-two block



Features

National Crane Series 500E2

- 16,3 t (18 USt) maximum capacity
- 36,9 m (121 ft) maximum vertical reach
- 24,7 m (81 ft) maximum vertical hydraulic reach

Three-section boom

With a capacity of 16,3 t (18 USt) the Series 500E2 is equipped with a three-section 21,6 m (71 ft) boom. The long boom allows the operator to perform more lifts without the use of a jib, reducing setup time and improving efficiency.



Outriggers

The Series 500E2 comes equipped with A-frame stabilizers and an optional single front outrigger.



Easy Glide boom wear pads

Easy Glide boom wear pads reduce the conditions that cause boom chatter and vibration. The net result is smoother crane operation.



Improved serviceability

- Bearings on the boom extension and retract cables can be greased through access holes in the boom side plates
- Removable winch allows the internal telescoping cylinder to be removed quickly, without dismantling the boom
- Internal anti-two-block wire routing eliminates external reel and wire to protect crane components
- The boom sheave case is open, allowing access to replace the internal anti-two-block wire and to observe internal boom components
- Internal boom parts have been reduced, decreasing service time when rebuilding the machine

Features

Best in class performance and serviceability

- The steel torsion box and flatbed further reduce frame flex
- Speedy-reeve boom tip and sheave blocks simplify rigging changes by decreasing the time needed to change line reeving
- Crane components painted before assembly reduce the chance of rust, improve serviceability and enhance the appearance of the crane
- A control knob located on the swing motor brake release valve can be easily adjusted to the crane operator's swing speed preference
- Rear stabilizers include an independent stabilizer control and bolt/clamp on mounting



* Product may be shown with optional equipment.

Contents

| | |
|-------------------------|----|
| Mounting configurations | 5 |
| Specifications | 6 |
| Capacities | 8 |
| Dimensions | 12 |
| Accessories | 13 |



Mounting configurations

The configurations are based on the Series 500E2 with an 85% stability factor. The complete unit must be installed in accordance with factory requirements and a test performed to determine actual stability and counterweight requirements since individual truck chassis vary.

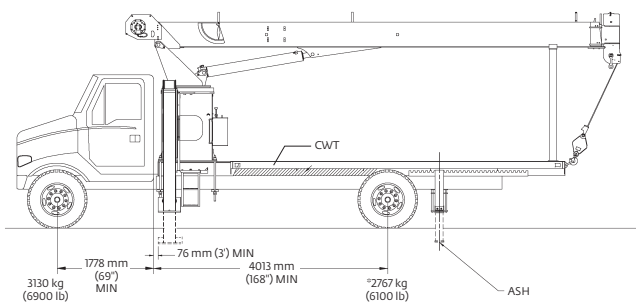

This configuration is the least expensive method for the Model 571E2. This mount, with the crane mounted behind the cab, requires the least weight of all mounts for stability; thus, you can haul larger payloads on your truck. It requires standard subbase and rear (ASH) stabilizers.

| | |
|---|---|
| Configuration 1 with Torsion Box – 180° Full Capacity Work Area | |
| Working area | 180° |
| Gross Axle Weight Rating Front..... | 5443 kg (12,000 lb) |
| Gross Axle Weight Rating Rear..... | 9525 kg (21,000 lb) |
| Gross Vehicle Weight Rating..... | 14 968 kg (33,000 lb) |
| Wheelbase | 602 cm (237 in) |
| Cab to Axle/trunnion (CA/CT) | 427 cm (168 in) |
| Frame Section Modulus (SM) under crane: | |
| 758 MPa (110,000 PSI)..... | 261 cm ³ (15.9 in ³) |
| Frame Section Modulus (SM) over rear stabilizers: | |
| 758 MPa (110,000 PSI)..... | 213 cm ³ (13 in ³) |
| Stability Weight, Front | 3130 kg (6900 lb) minimum* |
| Stability Weight, Rear | 2767 kg (6100 lb) minimum* |
| Estimated Average Final Weight | 13 608 kg (30,000 lb) |

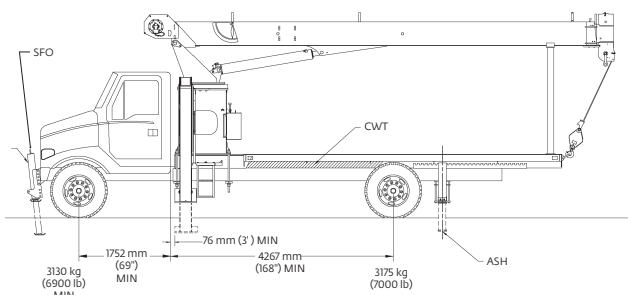

Requires front SFO stabilizer to give machine full capacity 360° around the truck. Truck must meet the minimum requirements above. Front stabilizer gives the machine a solid base, helping the operator control loads precisely.

| | |
|---|---|
| Configuration 2 with Torsion Box – 360° Full Capacity Work Area (Extended front frame rails required for SFO installation.) | |
| Working area | 360° |
| Gross Axle Weight Rating Front..... | 5443 kg (12,000 lb) |
| Gross Axle Weight Rating Rear..... | 9525 kg (21,000 lb) |
| Gross Vehicle Weight Rating..... | 14 968 kg (33,000 lb) |
| Wheelbase | 602 cm (237 in) |
| Cab to Axle/trunnion (CA/CT) | 427 cm (168 in) |
| Frame Section Modulus (SM) under crane: | |
| 758 MPa (110,000 PSI)..... | 261 cm ³ (15.9 in ³) |
| Frame Section Modulus (SM) over rear stabilizers: | |
| 758 MPa (110,000 PSI)..... | 213 cm ³ (13 in ³) |
| Stability Weight, Front | 3130 kg (6900 lb) minimum* |
| Stability Weight, Rear | 3175 kg (7000 lb) minimum* |
| Estimated Average Final Weight | 13 835 kg (30,500 lb) |

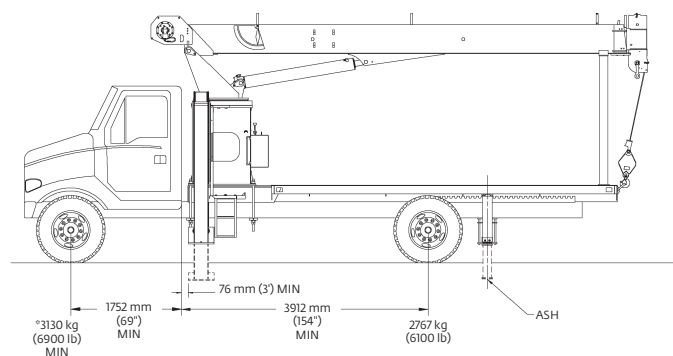

Allows the installation of the Model 560E2 on a chassis with a small frame by using the standard sub-base for 18 ft bed. In most cases, the chassis will not require reinforcing, and the amount of counterweight required is minimized, increasing payload capacities.

| | |
|---|---|
| Configuration 3 with Torsion Box – 180° Full Capacity Work Area | |
| Working area | 180° |
| Gross Axle Weight Rating Front..... | 5443 kg (12,000 lb) |
| Gross Axle Weight Rating Rear..... | 9525 kg (21,000 lb) |
| Gross Vehicle Weight Rating..... | 14 968 kg (33,000 lb) |
| Wheelbase | 566 cm (223 in) |
| Cab to Axle/trunnion (CA/CT) | 391 cm (154 in) |
| Frame Section Modulus (SM) under crane: | |
| 758 MPa (110,000 PSI)..... | 261 cm ³ (15.9 in ³) |
| Frame Section Modulus (SM) over rear stabilizers: | |
| 758 MPa (110,000 PSI)..... | 213 cm ³ (13 in ³) |
| Stability Weight, Front | 3084 kg (6800 lb) minimum* |
| Stability Weight, Rear | 2494 kg (5500 lb) minimum* |
| Estimated Average Final Weight | 13 040 kg (28,750 lb) |

Notes:

- Gross Vehicle Weight rating (GVWR) is dependent on all components of the vehicle (axles, tires, springs, frame, etc.) meeting manufacturers' recommendations: always specify GVWR when purchasing trucks
- Diesel engines require a variable speed governor for smooth crane operation; electronic fuel injection requires EET engine remote throttle

- All mounting data is based on a National Series 500E2 with an 85% stability factor
- The complete unit must be installed in accordance with factory requirements, and a test performed to determine actual stability and counterweight requirements per SAE J765; contact the factory for details
- Transmission neutral safety interlock switch is required

**Estimated axle scale rates prior to installation of crane, stabilizers and subbase for 85% stability.*

Specifications

Boom and jib combinations data

Available in two basic models:

Model 560E2 – Equipped with a 7,31 m - 18,29 m (24 ft - 60 ft) three-section boom. This model can be equipped with a 7,01 m - 12,50 m (23 ft - 41 ft) two-section jib. Maximum tip height with 12,50 m (41 ft) jib is 33,53 m (110 ft).

7,31 m - 18,29 m (24 ft - 60 ft) three-section boom.

5FJ41M 7,01 m - 12,50 m (23 ft - 41 ft) two-section jib



Model 571E2 – Equipped with a 8,23 m - 21,65 m (27 ft - 71 ft) three-section boom. This model can be equipped with a 7,01 m - 12,50 m (23 ft - 41 ft) two-section jib. Maximum tip height with 12,50 m (41 ft) jib is 36,9 m (121 ft).

8,23 m - 21,65 m (27 ft - 71 ft) three-section boom.

5FJ41M 7,01 m - 12,50 m (23 ft - 41 ft) two-section jib



Note: Maximum tip is measured with outriggers/stabilizers fully extended.



Specifications

500E2 winch data

- All winch pulls and speeds are shown on the fourth layer.
- Winch line pulls would increase on the first and second layers.
- Winch line pulls may be limited by the winch capacity or the ANSI 5 to 1 cable safety factor, shown below this chart.
- Hook blocks are rated at maximum capacity for the block. **Do not exceed rated cable pull with any block.**

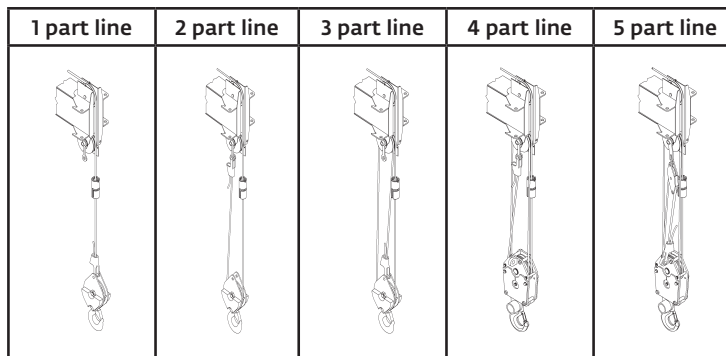

| Winch | Cable supplied | Average breaking strength | Max pull | Max pull | Max pull | Max pull | Max pull |
|--------------------------|-------------------------------------|---------------------------|----------------------|------------------------|--------------------------|--------------------------|--------------------------|
| Standard planetary winch | 9/16 in diameter rotation resistant | 17 463 kg (38,500 lb) | 3492,66 kg (7700 lb) | 6985,32 kg (15,400 lb) | 10 477,98 kg (23,100 lb) | 13 970,65 kg (30,800 lb) | 14 514,96 kg (36,000 lb) |

| Layer | Winch pull | | Winch speed | | BOS winch speed | | Rope capacity | |
|-------|------------|--------|-------------|-----|-----------------|-----|---------------|-----|
| | kg | lb | mpm | fpm | mpm | fpm | m | ft |
| 1 | 4708 | 10,380 | 48 | 157 | 68 | 222 | 19 | 64 |
| 2 | 4246 | 9360 | 53 | 175 | 75 | 246 | 41 | 136 |
| 3 | 3865 | 8520 | 59 | 192 | 83 | 271 | 65 | 215 |
| 4 | 3547 | 7820 | 64 | 209 | 90 | 294 | 91 | 301 |
| 5 | 3279 | 7230 | 69 | 257 | 97 | 318 | 120 | 394 |

Note: All ratings based on 128,7 LPM at 22,75 MPa (34 GPM at 3300 psi)
Burst of Speed maximum pull = 1361 kg (3000 lb)

| Winch | Bare drum pull | Allowable cable pull |
|---------------------------------------|----------------------|----------------------|
| With standard rotation resistant rope | 4627 kg (10,2000 lb) | 3493 kg (7700 lb) |

| Block type | Loadline deduct | |
|-----------------|---------------------|-----------------|
| | Rating | Weight |
| Downhaul weight | 3,49 t (3.85 USt) | 68 kg (150 lb) |
| 1-sheave block | 10,48 t (11.55 USt) | 91 kg (200 lb) |
| 2-sheave block | 17,46 t (19.25 USt) | 161 kg (355 lb) |

Capacities

Series 560E2: 60 ft boom

National Crane will send you a chart on request – or you may secure needed load rating information through your nearest National Crane dealer.

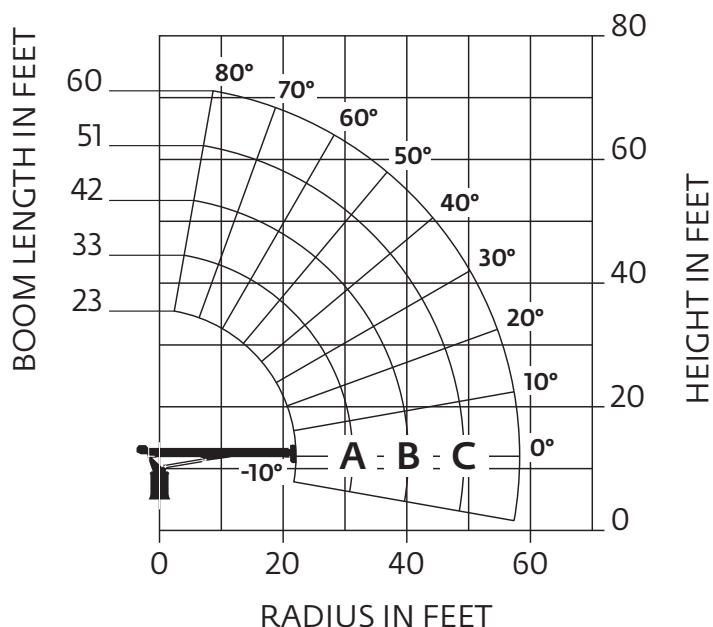

CAUTION:

- Do not operate crane booms, jib extensions, any accessories or loads within 3 m (10 ft) of live power lines or other conductors of electricity.
- Jib and boom capacities shown are maximum for each section.
- Do not exceed capacities at reduced radii
- Load ratings shown on the load rating charts are maximum allowable loads with the outriggers properly extended on a firm, level surface and the crane leveled and mounted on a factory recommended truck.
- Always level the crane with the level indicator located on the crane.
- The operator must reduce load to allow for factors such as wind, ground conditions, operating speeds and their effects on freely suspended loads.
- Overloading this crane may cause structural collapse or instability.
- Weights on any accessories attached to the boom or loadline must be deducted from the load chart capacities.
- Do not exceed jib capabilities at any reduced boom lengths.
- Do not deadhead lineblock against boom tip when extending boom or winching up.
- Keep at least three wraps of loadline on drum at all times.
- Use only specified cable with this machine.

Load chart

| LOADED RADIUS (ft) | LOADED BOOM ANGLE (deg) | 23 ft BOOM (lb) | LOADED BOOM ANGLE (deg) | A 33 ft BOOM (lb) | LOADED BOOM ANGLE (deg) | B 42 ft BOOM (lb) | LOADED BOOM ANGLE (deg) | C 51 ft BOOM (lb) | LOADED BOOM ANGLE (deg) | 60 ft BOOM (lb) |
|--------------------|-------------------------|-----------------|-------------------------|-------------------|-------------------------|-------------------|-------------------------|-------------------|-------------------------|-----------------|
| 5 | 75 | 36,000 | | | | | | | | |
| 8 | 67 | 23,150 | 74 | 21,350 | | | | | | |
| 10 | 61.5 | 19,550 | 70 | 18,500 | 75 | 17,850 | | | | |
| 12 | 56 | 16,900 | 66.5 | 16,000 | 72.5 | 15,350 | 76 | 14,700 | | |
| 14 | 50.5 | 14,750 | 63 | 14,100 | 69 | 13,500 | 74 | 12,900 | 77 | 11,200 |
| 16 | 42 | 12,950 | 58.5 | 12,605 | 66.5 | 12,050 | 71.5 | 11,500 | 75.5 | 10,500 |
| 20 | 23 | 9400 | 50 | 10,250 | 60 | 9850 | 66.5 | 9400 | 71 | 9000 |
| 25 | | | 37.5 | 8050 | 52.5 | 8000 | 60.5 | 7650 | 66 | 7450 |
| 30 | | | 17 | 5550 | 43 | 6550 | 53.5 | 6400 | 60.5 | 6200 |
| 35 | | | | | 31 | 5250 | 46 | 5400 | 54.5 | 5300 |
| 40 | | | | | 8 | 3050 | 37 | 4500 | 48.5 | 4550 |
| 45 | | | | | | | 25 | 3600 | 41 | 3900 |
| 50 | | | | | | | | | 32.5 | 3300 |
| 55 | | | | | | | | | 21 | 2500 |
| | 0 | 5300 | 0 | 3350 | 0 | 2300 | 0 | 1600 | 0 | 1100 |

NOTE:

1. All capacities are in pounds, angles in degrees, radius in feet.
2. Loaded boom angles are given as reference only.
3. Shaded areas are structurally limited capacities.



Capacities

Series 560E2: 60 ft boom with 41 ft jib

National Crane will send you a chart on request – or you may secure needed load rating information through your nearest National Crane dealer.

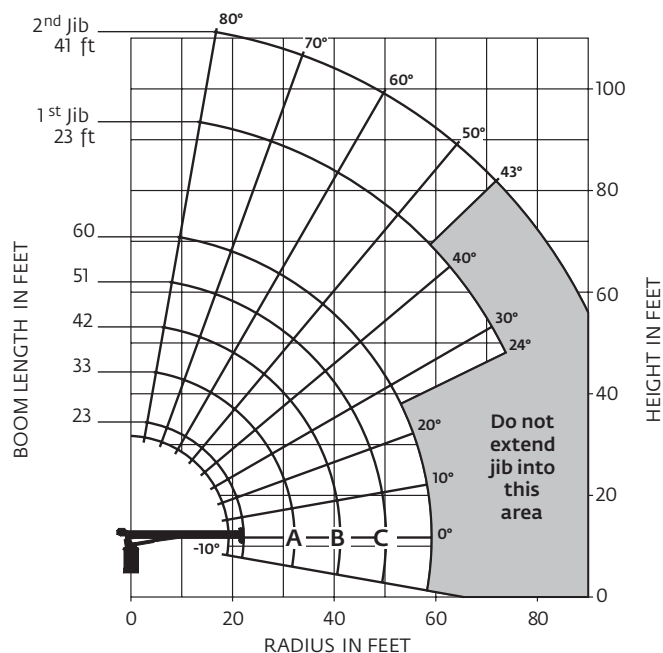

CAUTION:

- Do not operate crane booms, jib extensions, any accessories or loads within 3 m (10 ft) of live power lines or other conductors of electricity.
- Jib and boom capacities shown are maximum for each section.
- Do not exceed capacities at reduced radii
- Load ratings shown on the load rating charts are maximum allowable loads with the outriggers properly extended on a firm, level surface and the crane leveled and mounted on a factory recommended truck.
- Always level the crane with the level indicator located on the crane.
- The operator must reduce load to allow for factors such as wind, ground conditions, operating speeds and their effects on freely suspended loads.
- Overloading this crane may cause structural collapse or instability.
- Weights on any accessories attached to the boom or loadline must be deducted from the load chart capacities.
- Do not exceed jib capabilities at any reduced boom lengths.
- Do not deadhead lineblock against boom tip when extending boom or winching up.
- Keep at least three wraps of loadline on drum at all times.
- Use only specified cable with this machine.

Note:

1. Operate with jib by radius when main boom is fully extended. If necessary increase boom angle to maintain loaded radius.
2. Operate with jib by boom angle when main boom is not fully extended. Do not exceed rated jib capacities at any reduced boom lengths.

Load chart

| LOADED RADIUS (ft) | LOADED BOOM ANGLE (deg) | 23 ft BOOM (lb) | LOADED BOOM ANGLE (deg) | A 33 ft BOOM (lb) | LOADED BOOM ANGLE (deg) | B 42 ft BOOM (lb) | LOADED BOOM ANGLE (deg) | C 51 ft BOOM (lb) | LOADED BOOM ANGLE (deg) | 60ft BOOM (lb) | LOADED BOOM ANGLE (deg) | 23 ft JIB (lb) | LOADED BOOM ANGLE (deg) | 41 ft JIB (lb) |
|--------------------|-------------------------|-----------------|-------------------------|-------------------|-------------------------|-------------------|-------------------------|-------------------|-------------------------|----------------|-------------------------|----------------|-------------------------|----------------|
| 5 | 75 | 36,000 | | | | | | | | | | | | |
| 8 | 67 | 22,500 | 74 | 20,950 | | | | | | | | | | |
| 10 | 61.5 | 18,900 | 70 | 18,050 | 75 | 17,500 | | | | | | | | |
| 12 | 56 | 16,200 | 66.5 | 15,550 | 72.5 | 15,000 | 76 | 14,400 | | | | | | |
| 14 | 50.5 | 14,100 | 63 | 13,650 | 69 | 13,150 | 74 | 12,600 | 77 | 10,950 | | | | |
| 16 | 42 | 12,300 | 58.5 | 12,100 | 66.5 | 11,650 | 71.5 | 11,200 | 75.5 | 10,250 | | | | |
| 20 | 23 | 8700 | 50 | 9800 | 60 | 9500 | 66.5 | 9150 | 71 | 8700 | 76 | 3450 | | |
| 25 | | | 37.5 | 7600 | 52.5 | 7650 | 60.5 | 7350 | 66 | 7200 | 72.5 | 2850 | 76.5 | 2150 |
| 30 | | | 17 | 5050 | 43 | 6200 | 53.5 | 6100 | 60.5 | 6000 | 68 | 2400 | 73.5 | 1950 |
| 35 | | | | | 31 | 4900 | 46 | 5100 | 54.5 | 5050 | 65 | 2050 | 70.5 | 1600 |
| 40 | | | | | 8 | 2700 | 37 | 4200 | 48.5 | 4300 | 61 | 1750 | 67.5 | 1350 |
| 45 | | | | | | | 25.5 | 3300 | 41 | 3650 | 57 | 1500 | 64.5 | 1200 |
| 50 | | | | | | | | | 32.5 | 3000 | 53 | 1300 | 61.5 | 1050 |
| 55 | | | | | | | | | 21 | 2250 | 48.5 | 1150 | 58 | 900 |
| 60 | | | | | | | | | | | 43.5 | 1000 | 54.5 | 800 |
| 65 | | | | | | | | | | | 38 | 850 | 51 | 700 |
| 70 | | | | | | | | | | | 32 | 750 | 47 | 600 |
| 75 | | | | | | | | | | | 24 | 600 | 43 | 500 |
| | 0 | 4600 | 0 | 2900 | 0 | 1950 | 0 | 1300 | 0 | 850 | | | | |

NOTE:

1. All capacities are in pounds, angles in degrees, radius in feet.
2. Loaded boom angles are given as reference only.
3. Shaded areas are structurally limited capacities.

THIS CHART IS ONLY A GUIDE AND SHOULD NOT BE USED TO OPERATE THE CRANE.

Capacities

Series 571E2: 71 ft boom

National Crane will send you a chart on request – or you may secure needed load rating information through your nearest National Crane dealer.

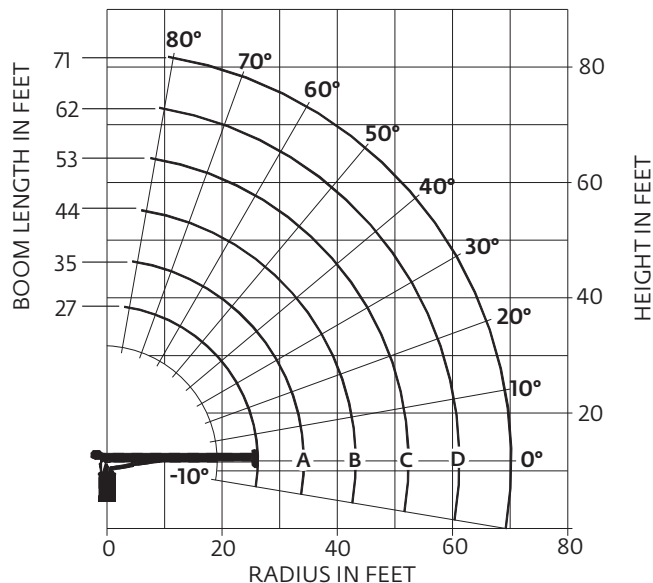

CAUTION:

- Do not operate crane booms, jib extensions, any accessories or loads within 3 m (10 ft) of live power lines or other conductors of electricity.
- Jib and boom capacities shown are maximum for each section.
- Do not exceed capacities at reduced radii
- Load ratings shown on the load rating charts are maximum allowable loads with the outriggers properly extended on a firm, level surface and the crane leveled and mounted on a factory recommended truck.
- Always level the crane with the level indicator located on the crane.
- The operator must reduce load to allow for factors such as wind, ground conditions, operating speeds and their effects on freely suspended loads.
- Overloading this crane may cause structural collapse or instability.
- Weights on any accessories attached to the boom or loadline must be deducted from the load chart capacities.
- Do not exceed jib capabilities at any reduced boom lengths.
- Do not deadhead lineblock against boom tip when extending boom or winching up.
- Keep at least three wraps of loadline on drum at all times.
- Use only specified cable with this machine.

Load chart

| LOAD RADIUS (ft) | LOADED BOOM ANGLE (deg) | 27 ft BOOM | LOADED BOOM ANGLE (deg) | A 35 ft BOOM | LOADED BOOM ANGLE (deg) | B 44 ft BOOM | LOADED BOOM ANGLE (deg) | C 53 ft BOOM | LOADED BOOM ANGLE (deg) | D 62 ft BOOM | LOADED BOOM ANGLE (deg) | 71 ft BOOM |
|------------------|-------------------------|------------|-------------------------|--------------|-------------------------|--------------|-------------------------|--------------|-------------------------|--------------|-------------------------|------------|
| 5 | 77.5 | 36,000 | | | | | | | | | | |
| 8 | 70.5 | 24,650 | 75.5 | 20,550 | | | | | | | | |
| 10 | 66 | 19,500 | 72 | 17,250 | 76.5 | 16,700 | 79.5 | 16,350 | | | | |
| 12 | 61 | 16,250 | 68.5 | 14,850 | 73.5 | 14,350 | 77 | 14,000 | | | | |
| 14 | 56 | 14,250 | 64.5 | 13,050 | 71 | 12,600 | 75 | 12,250 | 77.5 | 12,000 | | |
| 16 | 50.5 | 12,600 | 61 | 11,600 | 68 | 11,200 | 72.5 | 10,850 | 75.5 | 10,650 | 78 | 9600 |
| 20 | 37.5 | 9950 | 53 | 9450 | 62 | 9150 | 68 | 8850 | 72 | 8650 | 75 | 8000 |
| 25 | 14 | 6300 | 41 | 7450 | 55 | 7350 | 62 | 7150 | 67 | 6950 | 70.5 | 6750 |
| 30 | | | 26.5 | 5650 | 46 | 6060 | 55.5 | 5950 | 62 | 5800 | 66.5 | 5700 |
| 35 | | | | | 35.5 | 4900 | 48.5 | 5000 | 56.5 | 4900 | 61.5 | 4800 |
| 40 | | | | | 20 | 3600 | 40.5 | 4150 | 50.5 | 4200 | 57 | 4100 |
| 45 | | | | | | | 30.5 | 3400 | 43.5 | 3550 | 51.5 | 3550 |
| 50 | | | | | | | 14 | 2300 | 36 | 3000 | 46 | 3050 |
| 55 | | | | | | | | | 26 | 2400 | 39.5 | 2600 |
| 60 | | | | | | | | | | | 32 | 2200 |
| 65 | | | | | | | | | | | 22.5 | 1650 |
| | 0 | 4100 | 0 | 2650 | 0 | 1750 | 0 | 1200 | 0 | 750 | 0 | 400 |

NOTE:

1. All capacities are in pounds, angles in degrees, radius in feet.
2. Loaded boom angles are given as reference only.
3. Shaded areas are structurally limited capacities.



Capacities

Series 571E2: 71 ft boom with 41 ft jib

National Crane will send you a chart on request – or you may secure needed load rating information through your nearest National Crane dealer.

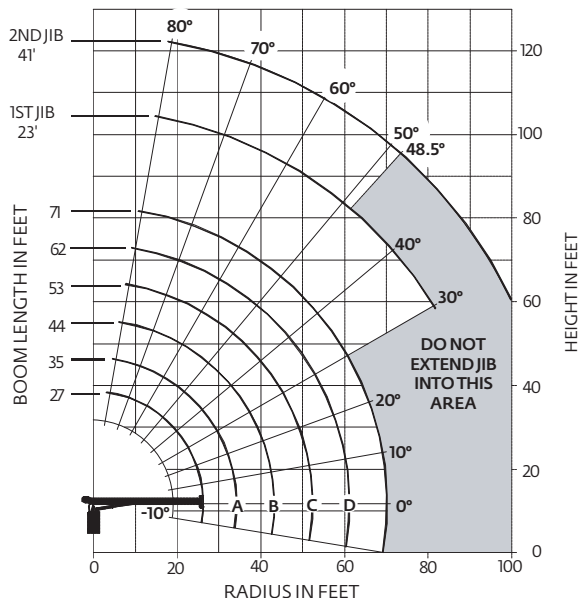

CAUTION:

- Do not operate crane booms, jib extensions, any accessories or loads within 3 m (10 ft) of live power lines or other conductors of electricity.
- Jib and boom capacities shown are maximum for each section.
- Do not exceed capacities at reduced radii
- Load ratings shown on the load rating charts are maximum allowable loads with the outriggers properly extended on a firm, level surface and the crane leveled and mounted on a factory recommended truck.
- Always level the crane with the level indicator located on the crane.
- The operator must reduce load to allow for factors such as wind, ground conditions, operating speeds and their effects on freely suspended loads.
- Overloading this crane may cause structural collapse or instability.
- Weights on any accessories attached to the boom or loadline must be deducted from the load chart capacities.
- Do not exceed jib capabilities at any reduced boom lengths.
- Do not deadhead lineblock against boom tip when extending boom or winching up.
- Keep at least three wraps of loadline on drum at all times.
- Use only specified cable with this machine.

Note:

1. Operate with jib by radius when main boom is fully extended. If necessary increase boom angle to maintain loaded radius.
2. Operate with jib by boom angle when main boom is not fully extended. Do not exceed rated jib capacities at any reduced boom lengths.

Load chart

| LOAD RADIUS (FEET) | LOADED BOOM ANGLE | 27 FT BOOM | LOADED BOOM ANGLE | A 35 FT BOOM | LOADED BOOM ANGLE | B 44 FT BOOM | LOADED BOOM ANGLE | C 53 FT BOOM | LOADED BOOM ANGLE | D 62 FT BOOM | LOADED BOOM ANGLE | 71 FT BOOM | LOAD RADIUS (FEET) | LOADED BOOM ANGLE | 23 FT JIB | LOADED BOOM ANGLE | 41 FT JIB |
|--------------------|-------------------|------------|-------------------|--------------|-------------------|--------------|-------------------|--------------|-------------------|--------------|-------------------|------------|--------------------|-------------------|-----------|-------------------|-----------|
| 5 | 77.5 | 36,000 | | | | | | | | | | | 20 | 77 | 3400 | | |
| 8 | 70.5 | 24,050 | 75.5 | 20,100 | | | | | | | | | 25 | 74.3 | 2900 | 77.3 | 2050 |
| 10 | 66 | 18,900 | 72 | 16,800 | 76.5 | 16,300 | 79.5 | 16,050 | | | | | 30 | 70.6 | 2450 | 74.5 | 1800 |
| 12 | 61 | 15,650 | 68.5 | 14,400 | 73.5 | 13,950 | 77 | 13,700 | | | | | 35 | 67.5 | 2100 | 72.2 | 1550 |
| 14 | 56 | 13,650 | 64.5 | 12,600 | 71 | 12,200 | 75 | 11,950 | 77.5 | 11,750 | | | 40 | 64.1 | 1800 | 69.5 | 1400 |
| 16 | 50.5 | 12,000 | 61 | 11,150 | 68 | 10,800 | 72.5 | 10,550 | 75.5 | 10,400 | 78 | 9350 | 45 | 60.3 | 1600 | 66.4 | 1200 |
| 20 | 37.5 | 9350 | 53 | 9000 | 62 | 8750 | 68 | 8550 | 72 | 8400 | 75 | 7750 | 50 | 57.5 | 1450 | 63.4 | 1050 |
| 25 | 14 | 5700 | 41 | 7000 | 55 | 6950 | 62 | 6850 | 67 | 6700 | 70.5 | 6500 | 55 | 53.8 | 1250 | 60.9 | 950 |
| 30 | | | 26.5 | 5200 | 46 | 5660 | 55.5 | 5650 | 62 | 5550 | 66.5 | 5450 | 60 | 49.8 | 1100 | 57.8 | 850 |
| 35 | | | | | 35.5 | 4500 | 48.5 | 4700 | 56.5 | 4650 | 61.5 | 4550 | 65 | 46 | 950 | 55.2 | 750 |
| 40 | | | | | 20 | 3200 | 40.5 | 3850 | 50.5 | 3950 | 57 | 3850 | 70 | 41.6 | 850 | 51.7 | 600 |
| 45 | | | | | | | 30.5 | 3100 | 43.5 | 3300 | 51.5 | 3300 | 75 | 36.6 | 750 | 48.1 | 500 |
| 50 | | | | | | | 14 | 2000 | 36 | 2750 | 46 | 2800 | 80 | 31 | 650 | | |
| 55 | | | | | | | | | 26 | 2150 | 39.5 | 2350 | | | | | |
| 60 | | | | | | | | | | | 32 | 1950 | | | | | |
| 65 | | | | | | | | | | | 22.5 | 1400 | | | | | |
| | 0 | 3500 | 0 | 2200 | 0 | 1350 | 0 | 900 | 0 | 500 | | | | | | | |

NOTE:

1. All capacities are in pounds, angles in degrees, radius in feet.
2. Loaded boom angles are given as reference only.
3. Shaded areas are structurally limited capacities.

THIS CHART IS ONLY A GUIDE AND SHOULD NOT BE USED TO OPERATE THE CRANE.

The individual crane's load chart, operating instructions and other instructional plates must be read and understood prior to operating the crane.

Dimensions

MAINTAIN
CLEARANCE
FOR R1144 (R45.00)
TAILSWING

| SERIES | RETRACTED LENGTH | EXTENDED LENGTH | G (WET) | DRY/WET | WITH OIL/WT |
|--------|------------------|-----------------|----------------|------------------------------------|------------------------------------|
| 560E2 | 23 ft 10 in | 60 ft | 1,60 m (63 in) | 6136 kg (13,582 lb) ⁰⁰⁶ | 6406 kg (14,123 lb) ⁰⁰⁶ |
| 571E2 | 27 ft 6 in | 71 ft | 1,91 m (75 in) | 6677 kg (14,721 lb) ⁰⁰⁶ | 6947 kg (15,316 lb) ⁰⁰⁶ |

⁰⁰⁶ INCLUDES STANDARD 18 ft SUBBASE
⁰⁰⁵ INCLUDES STANDARD 20 ft SUBBASE

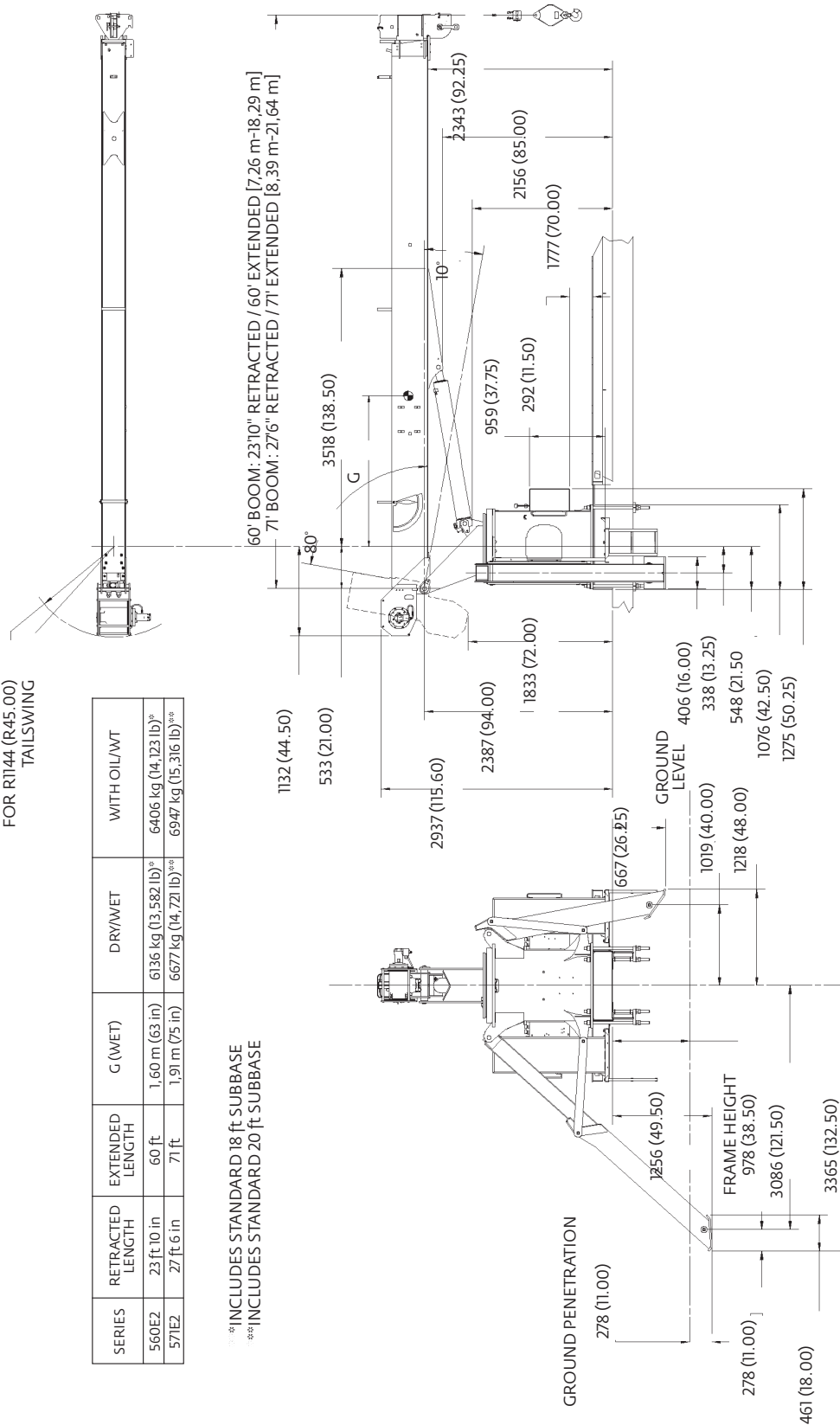

Dimensions are in mm (in) unless otherwise specified.



Accessories

Radio Remote Controls –

Eliminate the handling and maintenance concerns that accompany cabled remotes. Operate to a range of about 250 feet (76 m), varying with conditions.

- RB4R (R4 functions)

Heavy-duty Personnel Basket –

1,200-lb. (544-kg) capacity steel basket with safety loops for two passengers. Gravity leveling 72- x 42-inch (183- x 107-cm) platform. Fast attachment and secure locking systems. Load chart must show 2,300 (1043 kg) minimum to operate this accessory.

- BSA-1
- BSA-R1 (provides rotation)

Hydraulic Oil Cooler –

Automatic, self-contained radiator system with electric fans, cools oil under continuous duty-cycle operations.

- OC

Single Front Outrigger –

Center mount front stabilizer with 25" vertical stroke.

- SFO

Burst-of-Speed Winch –

Provides faster winch payout and pickup of unloaded cable.

- BOS

Bulkhead –

Steel 30" solid wall bulkhead.

- BHSD

Spanish-Language Danger Decals, Control Knobs, and Operators' Manuals –

- SDD
- SOM



Notes



Notes





Regional headquarters

Manitowoc - Americas

Manitowoc, Wisconsin, USA

Tel: +1 920 684 6621
Fax: +1 920 683 6277

Shady Grove, Pennsylvania, USA

Tel: +1 717 597 8121
Fax: +1 717 597 4062

Manitowoc - Europe, Middle East, Africa

Ecully, France

Tel: +33 (0)4 72 18 20 20
Fax: +33 (0)4 72 18 20 00

Manitowoc - Asia Pacific

Shanghai, China

Tel: +86 21 6457 0066
Fax: +86 21 6457 4955

Regional offices

Americas

Brazil

Alphaville

Mexico

Monterrey

Chile

Santiago

Europe, Middle East, Africa

Czech Republic

Netvorice

France

Baudemont

Cergy

Decines

Germany

Langenfeld

Hungary

Budapest

Italy

Lainate

Netherlands

Breda

Poland

Warsaw

Portugal

Baltar

Russia

Moscow

U.A.E.

Dubai

U.K.

Buckingham

Asia - Pacific

Australia

Brisbane

Melbourne

Sydney

China

Beijing

Chengdu

Guangzhou

India

Delhi

Hyderabad

Pune

Korea

Seoul

Philippines

Makati City

Singapore

Factories

Brazil

Alphaville

China

TaiAn

Zhangjiagang

France

Charlieu

La Clayette

Moulins

Germany

Wilhelmshaven

India

Pune

Italy

Niella Tanaro

Portugal

Baltar

Fânzeres

Slovakia

Saris

USA

Manitowoc

Port Washington

Shady Grove

This document is non-contractual. Constant improvement and engineering progress make it necessary that we reserve the right to make specification, equipment, and price changes without notice. Illustrations shown may include optional equipment and accessories and may not include all standard equipment.

