

GENERAL INFORMATION ONLY

Specifications

Lattice Boom Truck Crane

HC-238B

140 Ton (126.98 metric ton)

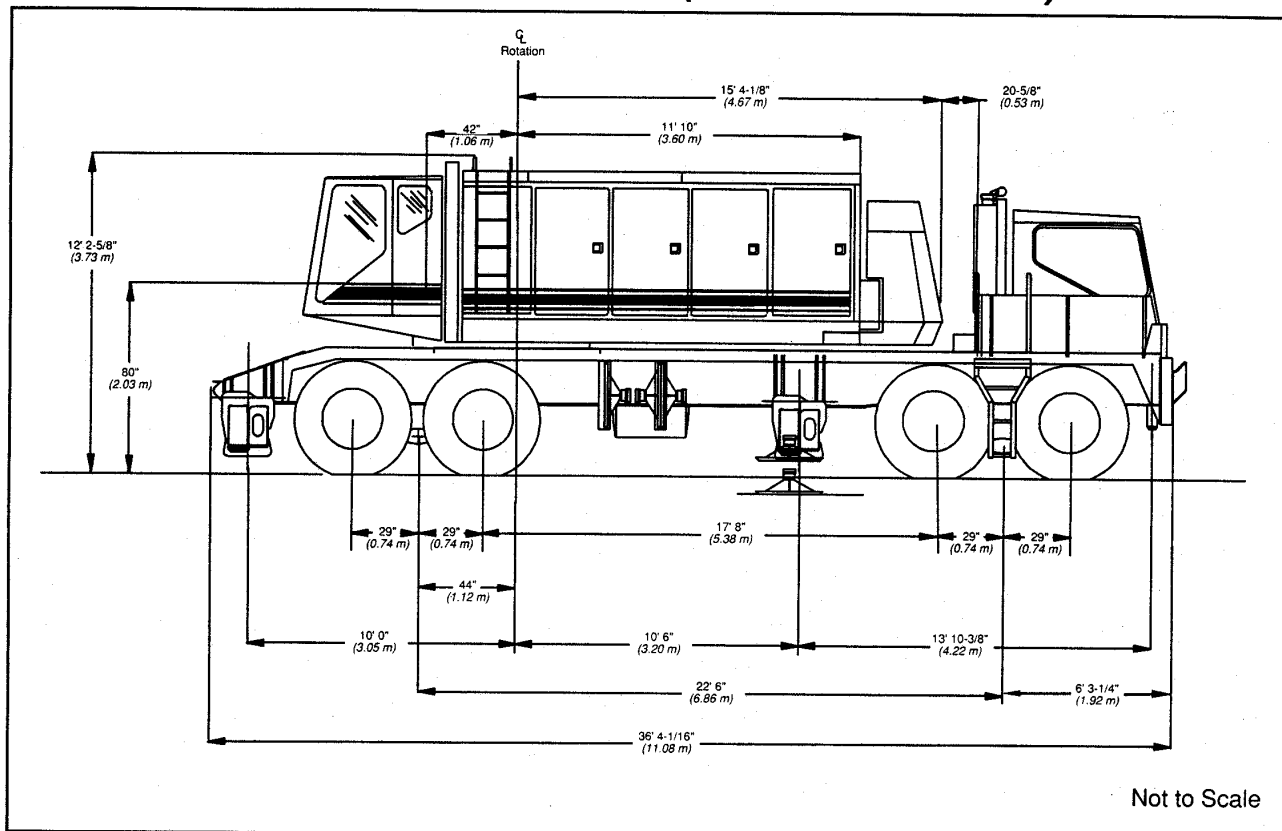

General dimensions	feet	meters
Overall width, outriggers extended, (over floats)	24' 6"	7.47
Overall width, outriggers extended, (c/l of jacks)	22' 0"	6.71
Overall width, outriggers retracted (floats removed)	11' 10"	3.60
Minimum ground clearance	9-9/16"	.24
Ground clearance under counterweight with machine on tires	4' 11-1/16"	1.50
Counterweight tailswing (across corners)	16' 3-9/16"	5.15
Overall cab width (upper)	11' 0"	3.35
Basic boom length - open throat	50' 0"	15.24
Basic boom length - hammerhead	30' 0"	9.14
Basic boom length - tapered tip	110' 0"	33.53
Radius of boom hinge pin	3' 6"	1.07
Height of boom hinge pin	6' 8"	2.03

General Dimensions — Open Throat Boom	feet	meters
Overall length with basic boom in travel position over rear of carrier with bumper counterweight	81' 8-1/4"	24.90
Overall length with basic boom in travel position over front of carrier	70' 0"	21.34
Height over boom live mast with basic boom in travel position over rear of carrier	12' 3-1/4"	3.74
Height over boom live mast with basic boom in travel position over front of carrier	14' 9-1/2"	4.51

General Dimensions — Tapered Tip Boom	feet	meters
Overall length with basic boom in travel position over rear of carrier with bumper counterweight	See	Note ①
Overall length with basic boom in travel position over front of carrier	See	Note ①
Height over boom live mast with basic boom in travel position over rear of carrier	See	Note ①
Height over boom live mast with basic boom in travel position over front of carrier	See	Note ①

① Note: Boom with tapered tip top section cannot be traveled over-the-road.

General Dimensions — Hammerhead Boom	feet	meters
Overall length with basic boom in travel position over rear of carrier with bumper counterweight	60' 5 1/8"	18.43
Overall length with basic boom in travel position over front of carrier	48' 9"	14.86
Height over boom live mast with basic boom in travel position over rear of carrier	13' 6-1/4"	4.12
Height over boom live mast with basic boom in travel position over front of carrier	16' 9-1/2"	5.12

GENERAL INFORMATION ONLY





Axle Loads — Approximate

Based on HC-238B crane upper equipped with 30,000# (13 608 kg) counterweight "A", boom lowering planetary, rear drum load lowering clutch, DD 6-71N diesel with single stage torque converter, mounted on Link-Belt 8 x 4, 11'10" (3.61 m) wide, 270" (6.86 m) wheelbase carrier with DD 8V-92TAC DDEC diesel, 14:00x24L (20 ply rating) transport type tires, hydraulic outriggers front and rear and front center hydraulic jack, 5 floats in storage racks, and 11,400# (5 171 kg) front bumper counterweight "A". Adjust axle loadings accordingly for the following components:	Basic Machine Gross Weight		Upper facing front				Upper facing rear				
	**	lbs.	kg	lbs.	kg	lbs.	kg	lbs.	kg	lbs.	kg
	A	70,810	32 119	-13,585	-6 162	84,395	38 282	36,670	16 633	34,140	15 486
B	74,415	33 755	39,405	17 874	35,010	15 881	39,405	17 874	35,010	15 881	
C	145,225	65 874	25,820	11 712	119,405	54 162	76,075	34 508	69,150	31 366	
Component Weights			Front axle		Rear axle		Front axle		Rear axle		
	lbs.	kg	lbs.	kg	lbs.	kg	lbs.	kg	lbs.	kg	
Upperstructure —											
Boom hoist planetary	790	358	-90	-41	880	-399	350	159	440	199	
Boom lowering clutch (high speed)	420	191	-50	-23	470	214	180	82	240	109	
Boomhoist wire rope - 675' (205.74 m), 7/8" (22 mm) diameter, type "T"	970	440	-110	-50	1,080	490	420	191	550	249	
Front drum lowering clutch	620	281	70	32	550	249	130	59	490	222	
Front drum load hoist or lowering planetary	790	358	80	36	710	322	170	77	620	281	
Front drum wire rope - 900' (274.32 m), 1" (25 mm) diameter, type "N"	1,665	755	180	81	1,485	674	360	163	1,305	592	
Rear drum load hoist or lowering clutch	790	358	-20	-9	810	367	270	122	520	236	
Rear drum wire rope - 900' (274.32 m), 1" (25 mm) diameter, type "N"	1,1665	755	-35	-16	1,700	771	575	261	1,090	494	
Third drum (with front drum load lowering clutch and gear to power third drum)	2,360	1,070	420	190	1,940	880	350	158	2,010	912	
Third drum - as above, but with load lowering clutch	590	268	120	54	470	214	70	32	520	236	
Third drum wire rope - 460' (140.21 m), 7/8" (22 mm) diameter, type "N"	660	299	140	64	520	235	80	36	580	263	
Upper counterweight "A"	-30,000	-13,608	12,895	5 849	-42,895	-19 457	-22,680	-10 288	-7,320	-3 320	
Upper counterweight "B"	30,000	13,608	-13,945	-6 325	43,945	19 933	23,735	10 766	6,265	2 842	
Optional Cummins LT10-200 diesel with three-stage torque converter	290	132	-85	-39	375	170	180	82	110	50	
Crane booms and auxiliary equipment -											
50' (15.24 m) basic open throat boom with accessories	6,720	3 048	12,700	5 762	-5,980	-2 714	-10,500	-4 763	17,220	7 811	
25' (7.62 m) open throat boom top section only	-4,610	-2 091	-10,720	-4 862	6,110	2 771	9,220	4 182	-13,830	-6 273	
30' (9.14 m) basic hammerhead boom with accessories	5,060	2 295	6,530	2 962	-1,470	-667	-4,880	-2 214	9,940	4 509	
5' (1.52 m) hammerhead boom top section only	-2,950	-1 338	-4,550	-2 064	1,600	726	3,590	1 628	-6,540	-2 966	
Boom stops	660	299	200	91	460	208	10	5	650	294	
Boom live mast (retracted and horizontal), bridle and spreader bar	7,000	3 175	7,960	3 610	-960	-435	-5,680	-2 576	12,680	5 751	
Carrier -											
Front outrigger box, beams and jacks	-7,500	-3 402	-4,720	-2 141	-2,780	-1 261	-4,720	-2 141	-2,780	-1 261	
Rear outrigger box, beams and jacks	-7,500	-3 402	-2,110	-957	-9,610	-4 359	2,110	957	-9,610	-4 359	
Front and rear outrigger floats (4)	-680	-308	-190	-86	-490	-222	-190	-86	-490	-222	
Front center jack float (1)	-130	-59	-50	-23	-80	-36	-50	-23	-80	-36	
Bumper counterweight "A"	-11,400	-5 171	-14,850	-6 736	3,450	1 565	-14,850	-6 736	3,450	1 565	
Cummins N14-460E diesel engine	400	181	425	193	-25	-11	425	193	-25	-11	

** A—Upper, B—Carrier C—Total

GENERAL INFORMATION ONLY



Carrier

■ Type

270" (6.86 m) wheelbase, 8 x 4 drive. 11' 10" (3.61 m) wide.

Frame — Main members heat treated alloy steel; machined surface for mounting turntable bearing. Formed channel front bumper. Towing shackles front and rear.

Turntable bearing — Outer race, with integral swing (ring) gear bolted to carrier.

■ Bumper Counterweight

Easily removed, mounts on front bumper hooks. Refer to lifting capacity charts for counterweight requirements. 11,400 lb. (5 171 kg) counterweight "A".

■ Axles

Front- Tubular; bogie beam mounted tandem axles, single wheels. 115" (2.92 m) track.

Rear- Planetary type, bogie mounted tandem axles, dual wheels. 110.25" (2.80 m) track.

Suspension — Hendrickson rubber bushed front and bronze bushed rear equalizer beams with rubber bushed torque rods.

Wheels and rims — Front; cast spoke type. Rear; integral with planetary hubs.

■ Tires

Single tires front; dual tires rear.

Standard - 14:00 x 24L (20-ply rating) transport type tread.

Optional - Consult factory.

■ Outriggers

Full width, double box, front and rear pin connected to carrier frame. Hydraulically operated beams and jack cylinders individually controlled from each side of carrier. Hydraulic power supplied by belt-driven hydraulic pump. Check valve at each jack cylinder.

Optional - Hydraulic outrigger box pin puller.

Front center hydraulic jack with float

Standard- Single hydraulic jack, with float, mounted at front of the carrier. Jack float assembly required for handling 360° swing rated capacities.

Floats — Low profile, alloy steel; 30" (0.76 m) square base.

■ Brakes

8-wheel air brakes.

Service — Dual circuit with modulated emergency brakes. Bendix dual circuit 8 wheel air brakes with service chambers on 4 front wheels and spring applied, air released emergency, parking, service chambers on 4 rear wheels. Air dryer standard.

Size —

Rear wheels; 20-1.4" x 7" (0.51 x 0.18 m)
Front wheels; 16-1.2" x 6" (0.42 x 0.15 m)

■ Steering

Sheppard full integral hydraulic power with one master gear, one slave gear and one hydraulic pump for each axle. Steering mounted high on side of frame to minimize exposure to hazards. Separate master and slave for each axle eliminates transfer of steering force from entire system into one axle which could overload and damage linkage. Steering wheel is mechanically connected to axles to allow steering (with increased steering input effort) in the event of hydraulic system failure. Multiple pumps minimize possibility of total hydraulic system failure and only require increase in steering input effort sufficient to compensate for that portion of system that failed. High speed, high power system to maximize maneuverability both on the job site and on the road.

■ Engine

Diesel; 12/24-volt alternator, starter, pressure lubrication, hydraulic pump, dry type air cleaner, and 24 c.f.m. (.68 m³/min) air compressor.

Standard - Detroit Diesel 8V-92 TAC diesel, 8 cylinder. See page 5 for details.

Optional - Cummins N14-460E (available 1991). See page 5 for details.

Clutch - Lipe-Rollway 15-1.2" (0.39 m) 2 plate, dry disc.

■ Transmissions

Main - Eaton RTX 14708LL; ten speeds forward, three reverse.

Auxiliary - Spicer P-1241-C; 4-speed, midship mounting.

■ Cab

One-man, offset, fully enclosed. Air suspension mounted bucket seat with seat belt. Noise absorbing insulation with vinyl covering, sound reduction headliner, rubber floor mat; isolated from engine compartment rubber mounted for sound level reduction. Instrument panel and dash includes speedometer, odometer, voltmeter, and gauges for fuel, engine temperature, air and oil pressures. Low air pressure warning buzzer, key locking switch, starter, tachometer, fire extinguisher, heater and defroster, 2-speed electric windshield wiper, and windshield washer. Tilt and telescope steering column.

■ Electrical System

12-volt; including dual sealed beam headlights, directional signals with 4-way flashing system, stop and tail lights, clearance lights, horn, lighting of instrument panel, dome light, headlight dimmer switch, and two 12-volt, 8D batteries. Individual switches provide circuit control for hydraulic outrigger solenoid valves; one control stat on each side of carrier.

■ Fuel Tank

One 85 gallon (322 liter) capacity tank; side mounted on carrier frame.

■ Auxiliary Equipment

Standard: West Coast type rear view mirrors, lug wrench, 2-way reading bubble levels. High pressure lube fittings at all bearing points. Hand grab rails, carrier deck access ladder, back-up alarm, skid-resistant finish on carrier deck.

Optional: trailer hitch; includes air and electric connections at rear of carrier for trailer lights and air brakes.

GENERAL INFORMATION ONLY



GENERAL INFORMATION ONLY

Link-Belt
CONSTRUCTION EQUIPMENT

Engine Specifications	Detroit Diesel 8V-92 TAC DDEC	Cummins N14-460E
Number of cylinders	8	6
Bore	4.84" (0.12 m)	5.5" (0.14 m)
Stroke	5" (0.13 m)	6" (0.15 m)
Piston Displacement	736 cu. in. (12 061 cm ³)	855 cu. in. (14 013 cm ³)
Max. brake h.p. @ r.p.m.	450 (335.56 kw) @ 2,100	460 (343.02 kw) @ 1,700 or 350 (261.00 kw) @ 2,100
Governed load speed r.p.m.	2,100	2,100
Peak torque @ r.p.m.	1,425 ft. lbs. (1 932 j) @ 1,200	1,550 ft. lbs. (2 102 j) @ 1,200
Electrical system	12/24-volt charging/24-volt starting	12/24-volt charging/24-volt starting
Batteries	Four 12-volt	Four 12-volt
Air compressor	Bendix TU-FLO 1000, 24 cfm (.68 m ³ /min)	Cummins 30 cfm (.85 m ³ /min)

Carrier Speeds

Main — Eaton RTX 14708LL			Auxiliary — Spicer P-1241-C							
Gear		Ratio	4th (.81)		3rd (1.00)		2nd (1.24)		1st (2.37)	
			m.p.h.	km/hr	m.p.h.	km/hr	m.p.h.	km/hr	m.p.h.	km/hr
High	8th	.74	48.0	77.2	47.4	76.3	38.2	61.5	20.0	32.2
	7th	1.00	43.2	69.5	35.1	56.5	28.3	45.5	14.8	23.8
	6th	1.36	31.8	51.2	25.8	41.5	20.8	33.5	10.9	17.5
	5th	1.83	23.6	38.0	19.2	30.9	15.5	24.9	8.1	13.0
Low	4th	2.53	17.1	27.5	13.9	22.4	11.2	18.0	5.9	9.5
	3rd	3.40	12.7	20.4	10.3	16.6	8.3	13.4	4.4	7.1
	2nd	4.63	9.3	15.0	7.6	12.2	6.1	9.8	3.2	5.1
	1st	6.24	6.9	11.1	5.6	9.0	4.5	7.2	2.4	3.9
	L	9.42	4.6	7.4	3.7	6.0	3.0	4.8	1.6	2.6
Deep reduct-ion	LL	14.56	3.0	4.8	2.4	3.9	1.9	3.1	1.0	1.6
Hi Rev.	Rev.	2.89	15.0	24.1	12.1	19.5	9.8	15.8	5.1	8.2
Lo Rev.	Rev.	9.85	4.4	7.1	3.6	5.8	2.9	4.7	1.5	2.4
Deep Reduc-tion	Rev.	15.22	2.8	4.5	2.3	3.7	1.9	3.1	1.0	1.6
Deep Reduction @ 1,200 rpm	LL	14.56	1.7	2.7	1.4	2.3	1.1	1.8	.6	1.0
Deep Reduction @ 1,200 rpm	Rev.	15.22	1.6	2.6	1.3	2.1	1.0	1.6	.6	1.0

Turning Ability

Turning circle diameter	Curb clearance circle diameter	Vehicle clearance circle diameter	
Centerline of outer front tire	Outside of outer front tire	Over outside of front bumper	Over outside of front bumper counterweight "A"
102' 0" (31.09 m)	103' 4" (31.50 m)	104' 10" (31.95 m)	108' 10" (33.17 m)

Upperstructure

Frame

All welded, precision machined; machinery side housings welded integral with frame.

Turntable Bearing

Inner race of bearing bolted to machined surface on under side of frame.

Engines

Diesel; full pressure lubrication, oil filter, air cleaner, hour meter, foot and optional hand throttles. Manual control shutdown for DD engine, electrical shutdown for Cummins engine.



GENERAL INFORMATION ONLY

Engine	DD 6-71N w/single stage torque converter	DD 6-71N w/three stage torque converter	Cummins LT10-200 w/three stage torque converter
Number of cylinders	6	6	6
Bore	4.25" (108 mm)	4.25" (108 mm)	4.92" (125 mm)
Stroke	5" (127 mm)	5" (127 mm)	5.35" (136 mm)
Piston Displacement	426 cu. in. (6 976 cm ³)	426 cu. in. (6 976 cm ³)	611 cu. in. (10 014 cm ³)
Maximum h.p. @ full load speed rpm	171 hp (127 kW)	168 hp (125 kW)	200 (149 kW)
High idle speed	2,040 rpm	2,020 rpm	1,980 rpm
Peak torque @ converter stall	1,400 ft. lbs. (1 898 j)	2,360 ft. lbs. (3 200 j)	2,494 ft. lbs. (3 382 j)
Electrical system	12-volt	12-volt	12-volt
Batteries	One 12-volt	One 12-volt	Two 12-volt
Clutch or power take-off	Disconnect between engine and converter	Disconnect between engine and converter	Disconnect between engine and converter
Transmission			
Number chain wheel teeth	171	171	171
Number engine pinion teeth	21	22	22

Power Train

Transmissions

Quadruple width roller chain enclosed in oil tight chain case with integral lubrication system.

Fuel Tank

75 gallon (284 L) capacity fuel tank equipped with fuel gauge, fill pipe with flame arrester unit, and locking eye for padlock.

Machinery Gear Train

"Full Function" design, two-directional power available to all operating shafts; shafts mounted on anti-friction bearings in precision bored side housings. All load hoist, swing, and boomhoist functions independent of one another. Components such as gears, pinions, chain wheels, brake drums and clutch spiders involute splined to shafts. Drum gear clutch drum assemblies bolted together and mounted on shafts on anti-friction bearings. Machine-cut teeth on drum gears, pinions, spur gears, and chain wheel. Chain wheel and pinion fully enclosed and running in oil.

Principal Operating Functions

Control System

Speed-o-Matic® power hydraulics, a variable pressure system requiring no bleeding. Operating pressure is transmitted through oil to all operating cylinders. The system includes a pump to provide a constant flow of oil, an accumulator to maintain operating pressure, oil filter, relief valve, and variable pressure operator controlled valves to regulate the pressure to each drum clutch and other operating cylinders..

Hydraulic Oil Reservoir

Link-Belt, 12 gallon (45.4 liter) capacity with filter and strainer assembly.

Load Hoisting & Lowering

Wire rope drum gear train (front and rear main, and optional third, operating drums) powered by chain transmission from engine.

Load Hoist Drums

Front and rear main operating drums – One-piece, smooth 17-1/4" (0.44 m) root diameter. Extended length shafts permit installation of power load lowering clutches; special length shaft required for, and furnished with, optional planetary drive units for either or both drums.

Third operating drum - Optional; mounts forward of front main operating drum. One-piece, 12-1/4" (0.31 m) root diameter smooth drum; involute splined to shaft.

Drum Clutches

Speed-o-Matic® power hydraulic two-shoe clutches. Internal expanding, lined shoes; clutch spiders splined to shafts, clutch drums bolted to drum spur gears and mounted on shafts on anti-friction bearings.

Load Hoist clutches — Front and rear main, and optional third, operating drums – 23" (0.58 m) diameter, 6" (0.15 m) face width.

Load Lowering Clutches— Standard on rear main drum; optional on front main, and optional third, operating drums – 23" (0.58 m) diameter, 6" (0.15 m) face width.

Drum planetary drive units — *Optional;* available for load hoist or lowering on either or both front and rear main operating drums.

Planetary units mount on extended drum shafts between drum spur gears and two-shoe clutch drums. Available for either increased or decreased load hoist or lowering line speeds. Two-shoe clutches control standard line speeds. Planetary drive units controlled by external contracting brake brakes through push button located on control lever.

Drum Brakes

Two-piece, external contracting band; mechanically foot operated. Foot pedals equipped with latch to permit locking brake in applied position. *Optional:* automatic brakes for front and rear main operating drums.

Front and rear main drums - Brakes 34" (0.86 m) diameter, 5" (0.13 m) face width

Optional third drum - Brake 28 (0.71 m) diameter, 5" (0.13 m) face width.

Drum Rotation Indicators

Standard for front and rear main operating drums. Two electrically operated indicator buttons, recessed in drum clutch control lever handles; one button pulsates when rope drums rotate in one direction, and the other button pulsates when drums rotate opposite direction. Operator can adjust pulsations to determine either rope speed off drum or hook block speed based on specific number of parts of load hoist rope.

Swing System

Spur gear driven; single bevel gears (enclosed and running in oil) on horizontal and vertical swing shafts. Swing pinion, involute splined to vertical swing shaft, meshes with external teeth of swing gear integral with outer race of turntable bearing.

Swing clutches - 23" (0.58 m) diameter 6" (0.15 m) face width; lined aluminum shoes.



Link-Belt

CONSTRUCTION EQUIPMENT

Swing brake - External contracting band, spring applied, hydraulically released by operator controlled lever. Brake drum involute splined to vertical swing shaft; brake 20" (0.51 m) diameter, 3-1/4" (83 mm) face width.

Swing lock - Mechanically controlled pawl engages external teeth of turntable bearing swing (ring) gear.

Maximum swing speed — 2.8 r.p.m.

Boom Hoist/Lowering System

Independent, spur gear driven. Precision control - hoisting through power hydraulic two-shoe clutch; lowering through low speed planetary drive unit.

Boomhoist Drum

121'4" (0.31 m) root diameter, smooth; involute splined to shaft.

Boomhoist Drum Locking Pawl

Operator controlled; spring applied, mechanically released.

Boomhoist Clutch

23" (0.58 m) diameter, 6" (0.15 m) face width.

Boom lowering planetary - Mounts on outer end of shaft; planetary external contracting band brake hydraulically controlled by boom hoist/lowering control lever.

Boom Lowering Clutch

Optional: in addition to planetary boom lowering. Two-shoe clutch permits higher speed boom lowering mounted on shaft outside planetary unit, clutch drum bolted to outer face of planetary housing. Clutch power hydraulically controlled by depressing solenoid push button located on boom hoist/lowering control lever.

Boom hoist/lowering Brake

External contracting band, spring applied, hydraulically released as hoist clutch or lowering planetary are engaged. Brake drum involute splined to shaft; brake 28" (0.71 m) diameter, 5" (0.13 m) face width.

Boom hoist limiting device - Provided to restrict hoisting boom beyond recommended minimum radius; located on outer right-hand side of operator's cab.

Electrical System

Battery. 12-volt, 225 ampere hour, either one or two batteries depending on engine and 12-volt, 60 ampere alternator.

Optional - Battery lighting system, including two sealed beam automotive type, adjustable headlights located on cab front roof, one interior cab light and automotive type wiring.

Optional - Additional 50 watt sealed beam automotive type headlight mounted on boom. (Three maximum quantity recommended.)

Optional - Onan independent light plant with single cylinder four cycle, air cooled diesel engine with remote electric starting, 3,000 watt, 120-volt, single phase, 60 cycles A.C. including wiring in conduit, three interior interior cab lights, trouble lamp with cord and two 300 watt adjustable flood lights on cab front roof.

Optional - Additional 300 watt floodlights available for mounting on cab and boom.

Operators Cab

Environmental cab, modular type isolated from upper machinery cab. Tinted tempered glass panels in all windows, hand grab rail, adjustable, cushioned seat with headrest, armrests on control consoles, dry chemical fire extinguisher. **Optional:** cab heater/defroster (propane or hot water type) and windshield wiper.

Machinery Cab

Equipped with warning horn, hinged doors on two sides, rear, and top. Removable panels for machinery access, roof-top access ladder, and skid resistant finish on roof.

Gantry

Low type mounted at top rear of machinery side housings; supports boom suspension system.

Gantry bail - Contains seven 15" (0.38 m) root diameter sheaves, mounted on anti-friction bearings, for 16-part boomhoist wire rope reeving.

Counterweight

Total "AB" counterweight - 60,000 lbs. (27,216 kg). Counterweight "A" - 30,000 lbs. (13,608 kg); counterweight "B" - 30,000 lbs. (13,608 kg). Total "A" or "AB" counterweight power hydraulically raised from, or lowered to, carrier deck in seconds. Two hydraulically controlled frustums hold counterweight "A" in place; counterweight "B" bolts to top of "A".

Boom and Jib

Boom

Tubular; two-piece basic boom. Boom 60" (1.52 m) wide, 54" (1.37 m) deep at centerline of connections. Alloy steel, round tubular chords 3-5/8" (92 mm) outside diameter.

Base section - 25' (7.62 m) long. Boom feet 2-3/4" (70 mm) wide on 60" (1.52 m) centers. Lifting lugs on top side of base section to facilitate attaching carrying links for carrying base section, or for boom assembly.

Boom extensions - Available in 10' (3.05 m), 20' (6.10 m), 30' (9.14 m), and 40' (12.19 m) lengths, with appropriate pendants, and one hoist line deflector roller per extension.

Boom connections - In-line tapered pins.

Boom top section - Open throat; 25' (7.62 m) long. Permissible boom lengths without jib - minimum 50' (15.24 m); maximum 230' (70.10 m). Maximum boom length with jib - 200' (60.96 m).

Boompoin machinery - Six 21" (0.53 m) root diameter head sheaves mounted on anti-friction bearings.

Boom top section - Hammerhead; 5' (1.52 m) long. Permissible boom lengths without jib - minimum 30' (9.14 m), maximum 230' (70.10 m). Maximum boom length with jib - 200' (60.96 m).

Boompoin machinery - Six 21" (0.53 m) root diameter head sheaves mounted on anti-friction bearings.

Boom top section - Tapered tip; 45' (13.72 m) long, open throat on under side. Tapers from 60" x 54" (1.52 x 1.37 m) to 36" x 17" (0.91 x 0.43 m) cross section.

Boompoin machinery - Two 28-3/8" (0.72 m) root diameter sheaves; mounted on anti-friction bearings.

Pendant spreader bar - standard; for tapered tip top section only. Mounts between boom suspension pendants to maintain "straight line" pendant spread from boomhoist bridle/spreader bar to point near base of tapered tip top section, and to prevent interference between boom pendants and jib backstay lines. Use required for booms 210' (64.01 m) through 230' (70.10 m) long when equipped with jib; use optional for all other boom lengths.

Boom folding equipment - **Optional:** for folding 90' (27.43 m) or 110' (33.53 m) long booms equipped with open throat top section. Includes folding links, folding shaft, special 10' (3.05 m) long pin-connected boom extension with pendants, one hoist line deflector roller, (continued on page 8)



Link-Belt

CONSTRUCTION EQUIPMENT

and one boom peak wheel with 6.5 x 16 (6-ply rating) tire with tube. Special 10' (3.05 m) extension equipped with lifting lugs to accommodate boom folding shaft. (Combination of boom sections must be of such length that portion folded under is 20' (6.10 m) shorter than that above it.) Note: Folding equipment not available for booms equipped with hammerhead or tapered tip top sections.

■ Jib

Tubular; two-piece basic jib 28' (8.61 m) long (effective length 30' - 9.14 m); 36" (0.91 m) wide, 30" (0.76 m) deep at centerline of connections. Alloy steel tubular chords 2-1/4" (57 mm) outside diameter.

Base section - 13' 3" (4.04 m) long.

Jib extensions - Available in 10' (3.05 m) and 15' (4.57 m) lengths with appropriate length pendants. Maximum boom/jib lengths permitted: open throat and hammerhead booms - 200' (60.96 m) boom plus 60' (18.29 m) jib; tapered tip boom - 230' (70.10 m) boom plus 70' (21.34 m) jib.

Jib connections - In-line, tapered pins

Tip section - 15' (4.57 m) long, equipped with single peak sheave, 21" (0.53 m) root diameter, and mounted on anti-friction bearings. Anchor provided at peak of jib tip section for two-part load hoist wire rope (whipline).

■ Jib Mast

13' 6" (4.11 m) high, mounted on jib base section. Two deflector sheaves mounted within mast to guide whipline; mounted on anti-friction bearings. Two equalizer sheaves mounted on top of mast - one for jib frontstay line, one for jib backstay.

Jib staylines - Front and rear staylines vary in length depending on degree of jib offset from boom centerline; backstay lines attached at bottom end of boom top section.

Jib stops - Telescoping type, pinned from jib mast to boom top section and from jib mast to jib base section.

Items Applicable To Boom And Jib

■ Boom Stops

Dual lever-type; connected to bail shaft and top of boom base section; spring-loaded bumper ends.

■ Boom Live Mast

Supports boomhoist bridle and boom midpoint suspension pendants. Required for all boom lengths. Hydraulically extends from 25' 6" (7.77 m) to 30' 0" (9.14 m) working position, mechanically retracts to 25' 6" (7.77 m) position. Note: Retracted 25' 6" (7.77 m) position required for 30' (9.14 m) hammerhead boom maximum capacities, and used to reduce overall height for travel.

Boom live mast stops - Incorporated with boom stops; manually positioned when using live mast as short boom.

■ Boomhoist Bridle and Spreader Bar

Serves as connection for boom suspension system. Bridle contains eight 15" (0.38 m) root diameter sheaves, (for 16-part boomhoist reeving) mounted on anti-friction bearings, and two 15" (0.38 m) root diameter auxiliary load hoist sheaves, mounted on bronze bushings, which enable boom live mast to be used for machine assembly or disassembly. Spreader bar provides attachment point for boom main pendants.

Boom pendants - Standard; furnished for basic boom lengths plus appropriate length pendants with each boom extension.

Boom midpoint suspension pendants Required for all boom lengths exceeding 160' (48.77 m). Pendants connected at 85' (25.91 m) point of boom.

Deflector rollers - Deflect load hoist wire rope off boom to avoid chafing; steel rollers mounted on anti-friction bearings. One roller furnished with each boom extension, two with open throat boom top, and three with tapered tip top section.

Hydraulic boomfoot pin removal - Standard; a double acting hydraulic cylinder with integral cylinder rods/pins is permanently mounted between boomfoot lugs.

Auxiliary Equipment

■ Boom angle indicator

Pendulum type; mounted on boom base section.

Anti-two block warning device - *Optional*: available for main load hoist line, or main load hoist line and jib line.

Load moment device - *Optional*: audio/visual warning device for main load hoist line, or main load hoist line and jib line.

Automatic function kick-out system - *Optional*: for use with anti-two block warning device and/or load moment device. Note: requires optional automatic brakes.

Load hoist wire ropes - Main load hoist wire rope standard. Jib load hoist wire rope (whipline) furnished with machine only if jib is ordered.

Hook blocks - Blocks, or weighted ball with swivel hook, *optional* - refer to price list.

Bigge Crane and Rigging Co.

10700 Bigge Avenue
San Leandro, CA 94577
Phone: (888) 337-BIGGE or (510) 638-8100
Fax: (510) 639-4053
Email: info@bigge.com
Web site: www.bigge.com

GENERAL INFORMATION ONLY

We are constantly improving our products and therefore reserve the right to change designs and specifications.

● Link-Belt is a registered trademark. All rights reserved. Copyright 1990

Link-Belt Construction Equipment Company Lexington, Kentucky

A unit of Sumitomo Construction Machinery Co., Ltd

