



## AMERICAN HC 80 Hydraulic Crawler Crane



### FEATURES

- 80 tons (73 mt) max lift capacity
- 200 ft. (61 m) max lift crane boom length
- 170+60 ft. (52+18 m) max lift crane boom & jib length
- 240 ft. (73 m) max boom & luffing jib length
- Power up/down and freefall on main, auxiliary and optional third drum
- 32,400 lbs. (14 700 kg) max single line pull, 530 fpm (161 mpm) max line speed
- Quiet, comfortable operator's cab with excellent viewing range
- Shockless stop system gradually retards operating speed to reduce shocks when crane approaches lifting load or boom limits
- Two speed travel allows operator to select the best speed and power control for any condition
- Superior transportability:  
11 ft. 9.75 in. (3.6 m) width  
10 ft. 2 in. (3.09 m) height
- 88,000 lbs. (39 917 kg) transport weight including sideframes and boom inner
- Hydraulic counterweight removal system simplifies installation and removal

simple, available and  
cost effective™

Machines shown may have optional equipment.



## AMERICAN HC 80

### Hydraulic Crawler Crane

Max. Lifting Capacity:  
80 tons (73 mt)

#### 200 ft. (61 m) MAXIMUM LIFT CRANE BOOM

- 47HI tubular chord boom, pin connected.
- 20 ft. (12.4 m) inner and outer and 10/20 /30 ft. (3/6/9 m) available inserts provide boom compositions in 10 ft. (3 m) increments from 40 ft. (12.2 m) to 200 ft. (61 m).

#### ROBUST ENGINE

- 197 BHP @2100 RPM Cummins 6BTA5.9 turbocharged aftercooled diesel engine, 4 cycle, 6 cylinders. Fuel tank capacity is 60 gal. (227 l).

#### ENVIRONMENTAL OPERATOR'S CAB

- Designed to provide excellent viewing range and quiet, comfortable operation.
- 37 in. (.91 m) wide cab has wide curved windows on both top and bottom.
- Easy-to-operate modular and ergonomically designed controls reduce operator fatigue and increase productivity.
- Load Moment Indicator with interactive screen. Operator can select from three display modes: loaded condition diagram, rated lifting curve, rated lifting load table, and features a shockless stop system to reduce shocks.
- Adjustable operator's seat, radio, air conditioner, overhead window, sun visor, fan, overhead and front wipers, and drum rotation indicators standard.



Environmental operator's cab

#### HEAVY DUTY CARBODY AND CRAWLERS

- Fabricated steel carbody is deep box constructed with square axles for the crawler side frames. Precision machined top supports anti-friction swing circle and multiple pass hydraulic swivel joint.
- Crawlers have high alloy steel tumbler yokes and rigid fabricated structures with sealed rollers.
- 36" (914 mm) crawler shoes.
- Travel mechanism is set within shoe width.
- Side frames extended or retracted by cylinders inside the carbody.
- Two travel speed settings – .8/1.24 mph (1.3/2.0 km/h).
- 40% (22°) gradeability.

#### POWERFUL, HIGH-SPEED HOIST SYSTEM

- Identical inline, independent main and auxiliary load hoisting drums are grooved for 7/8 in. (22.4 mm) diameter rope. Line speed is 530 fpm (162 m/min), line pull, 32,400 lbs. (14 697 kg).
- Each drum, including optional third, has power up/down and freefall. Load hoists are further controllable in stepless mode.
- Ample work space in front of drums allows easy access for cable installation and maintenance.
- External contracting brake.
- Internal expanding band clutch.
- 3.3 rpm swing speed.



Hydraulic removable counterweight system

#### HIGH CAPACITY, DEPENDABLE HYDRAULIC SYSTEM

- Open circuit system has 2 variable displacement piston pumps with system capacity of 116 gpm (440 lpm)
- Hydraulic reservoir with 79 gal. (300 l) capacity and 10 micron filtration.
- Component working range is between -4 and 203° F (-20 and 95° C).
- Flip up doors provide easy access to engine and hydraulic components for service.

#### THREE PIECE REMOVABLE COUNTERWEIGHT

- Three piece pin connected counterweight can be assembled or disassembled easily within minutes.
- Hydraulic counterweight removal system is standard and utilizes the "A" frame and crane auxiliary drum to make the HC 80 one of the most transportable cranes in its class.
- Moves on three trucks with full boom and #9HL jib. Carbody sideframes and boom weigh in at under 88,000 lbs. (39 917 kg). At 11 ft. 9.75 in. (3.6 m) wide and 10 ft. 2 in. (3.09 m) high, the HC 80 at working weight will transport on a standard lowboy trailer.

#### OPTIONS INCLUDE:

- Third drum.
- Automotive type lights.
- Hydraulic power take off.
- Jib and jib inserts.
- Luffing jib attachment.
- 46HI angle boom.
- Single sheave extension.

For more information, product demonstration, or details on purchase, lease and rental plans, please contact your local Terex Cranes Distributor.

We reserve the right to amend these specifications at any time without notice. The only warranty applicable is our standard written warranty applicable to the particular product and sale. We make no other warranty, expressed or implied.

## TEREX CRANES

AMERICAN CRANE CORPORATION  
202 Raleigh Street  
Wilmington, NC 28412 USA  
(910) 395-8500 • FAX: (910) 395-8538  
E-mail: american@american-cranes.com

[www.terexlift.com](http://www.terexlift.com)





# AMERICAN HC 80

## Hydraulic Crawler Crane 47 HI Boom

### LIFT RATINGS IN POUNDS

With 47HI Offset Tip Boom and 58,100 Pound Counterweight

Boom	Radius (Feet)	Boom Angle (Degrees)	Side Frames Extended (Pounds)	From Boom Pt. to Ground (Feet)
40' (12.2M)	11	80.5	160,000 *	45
	12	79.0	160,000 *	45
	15	74.6	141,480	44
	20	67.0	87,810	42
	25	58.8	63,360	40
	30	49.9	49,350	36
	35	39.5	40,320	31
	40	25.8	33,970	23
50' (15.2M)	13	80.1	160,000 *	55
	15	77.8	141,440	54
	20	71.8	87,750	53
	25	65.6	63,280	51
	30	59.1	49,250	48
	35	52.0	40,220	45
	40	44.2	33,860	40
60' (18.3M)	14	80.8	145,370 *	65
	15	79.8	141,380	64
	20	74.9	87,660	63
	25	69.9	63,170	62
	30	64.7	49,120	60
	35	59.2	40,100	57
	40	53.4	33,730	54
	60	40.2	25,400	44
70' (21.3M)	16	80.5	125,040 *	74
	20	77.1	87,590	74
	25	72.9	63,090	72
	30	68.5	49,040	71
	35	64.0	40,020	68
	40	59.3	33,640	66
	50	49.2	25,310	58
	70	37.0	20,150	48
80' (24.4M)	17	80.9	109,250 *	84
	20	78.8	87,470	84
	25	75.1	62,960	83
	30	71.3	48,880	81
	35	67.5	39,870	79
	40	63.5	33,480	77
	50	55.1	25,140	71
	80	34.5	16,430	51
90' (27.4M)	19	80.7	94,540	94
	20	80.0	87,330	94
	25	76.8	62,810	93
	30	73.5	48,720	92
	35	70.1	39,720	90
	40	66.7	33,320	88
	50	59.5	24,970	83
	90	16.9	11,690	32

Boom	Radius (Feet)	Boom Angle (Degrees)	Side Frames Extended (Pounds)	From Boom Pt. to Ground (Feet)
100' (30.5M)	21	80.4	80,910	104
	25	78.1	62,690	103
	30	75.2	48,580	102
	35	72.2	39,590	101
	40	69.1	33,190	99
	50	62.8	24,840	94
	60	56.1	19,720	88
	70	48.9	16,130	81
	80	40.7	13,540	71
	90	30.7	11,560	56
	100	16.0	10,010	33
110' (33.5M)	22	80.8	72,040 *	114
	25	79.2	62,530	113
	30	76.5	48,420	112
	35	73.8	39,430	111
	40	71.1	33,020	109
	50	65.5	24,650	105
	60	59.6	19,560	100
	70	53.3	15,970	94
	80	46.4	13,360	85
	90	38.7	11,380	74
	100	29.2	9,840	59
120' (36.6M)	24	80.6	60,160 *	124
	25	80.1	60,160 *	124
	30	77.7	48,260	123
	35	75.2	39,260	121
	40	72.7	32,850	120
	50	67.6	24,470	116
	60	62.3	19,390	112
	70	56.8	15,800	106
	80	50.8	13,190	98
	90	44.3	11,210	89
	100	37.0	9,660	78
130' (39.6M)	25	80.9	50,970 *	134
	30	78.6	48,100	133
	35	76.4	39,120	132
	40	74.1	32,700	130
	50	69.4	24,320	127
	60	64.7	19,240	123
	70	59.6	15,650	118
	80	54.4	13,040	111
	90	48.7	11,060	103
	100	42.5	9,510	93
	140' (42.7M)	27	80.7	42,380 *
30		79.5	42,370 *	143
35		77.4	38,950	142
40		75.3	32,530	141
50		71.0	24,140	138
60		66.6	19,070	134
70		62.0	15,480	129

Boom	Radius (Feet)	Boom Angle (Degrees)	Side Frames Extended (Pounds)	From Boom Pt. to Ground (Feet)
140' (42.7M)	80	57.3	12,860	123
	90	52.2	10,880	116
	100	46.8	9,330	108
	110	40.9	8,070	97
	120	34.1	7,040	84
	130	25.8	6,180	66
	140	13.4	5,470	38
	150' (45.7M)	28	80.9	36,630 *
30		80.2	36,540 *	153
35		78.2	36,070 *	152
40		76.3	32,360	151
50		72.3	23,960	148
60		68.2	18,900	145
70		64.0	15,310	140
80		59.7	12,690	135
90		55.1	10,710	128
100		50.3	9,150	121
110		45.1	7,890	112
160' (48.8M)	120	39.4	6,860	101
	130	32.9	6,000	87
	140	24.9	5,270	69
	150	12.9	4,650	39
	30	80.8	31,770 *	163
	35	79.0	31,370 *	162
	40	77.1	30,790 *	161
	50	73.4	23,800	159
	60	69.7	18,750	155
	70	65.8	15,150	151
	80	61.8	12,530	146
90	57.6	10,550	141	
170' (51.8M)	100	53.2	8,990	134
	110	48.6	7,730	125
	120	43.6	6,690	116
	130	38.1	5,830	104
	140	31.8	5,100	90
	150	24.1	4,480	71
	160	12.5	3,950	40
	31	81.0	27,710 *	173
	35	79.6	27,340 *	173
	40	77.9	26,810 *	172
	50	74.4	23,610	169
60	70.9	18,580	166	
70	67.3	14,980	162	
80	63.6	12,360	158	
90	59.7	10,360	152	
180' (54.9M)	100	55.7	8,800	146
	110	51.5	7,540	139
	120	47.1	6,510	130
	130	42.2	5,650	120
	140	36.9	4,920	108
	150	30.8	4,290	93
	160	23.4	3,750	73
	170	12.1	3,290	41
	33	80.9	24,240 *	183
	35	80.2	24,110 *	183
	40	78.6	23,210 *	182

Form No. HC-80-CR-47HI3



**LIFT RATINGS IN POUNDS (continued)**

**With 47HI Offset Tip Boom and 58,100 Pound Counterweight**

Boom	Radius (Feet)	Boom Angle (Degrees)	Side Frames Extended (Pounds)	From Boom Pt. to Ground (Feet)	Boom	Radius (Feet)	Boom Angle (Degrees)	Side Frames Extended (Pounds)	From Boom Pt. to Ground (Feet)	Boom	Radius (Feet)	Boom Angle (Degrees)	Side Frames Extended (Pounds)	From Boom Pt. to Ground (Feet)
180' (54.9M)	50	75.3	20,080 *	180	190' (57.9M)	60	73.0	16,110 *	187	200' (61.0M)	60	73.8	13,800 *	198
	60	72.0	18,410	177		70	69.8	14,640	184		70	70.8	12,770 *	194
	70	68.6	14,800	173		80	66.5	12,010	180		80	67.8	11,840	191
	80	65.1	12,180	169		90	63.2	10,020	175		90	64.6	9,840	186
	90	61.6	10,190	164		100	59.8	8,460	170		100	61.4	8,270	181
	100	57.9	8,630	158		110	56.2	7,200	163		110	58.1	7,010	175
	110	54.0	7,360	151		120	52.5	6,160	156		120	54.6	5,970	169
	120	50.0	6,330	143		130	48.5	5,290	148		130	51.0	5,100	161
	130	45.7	5,460	134		140	44.4	4,550	138		140	47.2	4,370	152
	140	41.0	4,720	123		150	39.8	3,930	127		150	43.2	3,740	142
	150	35.8	4,100	111		160	34.8	3,390	114		160	38.8	3,190	131
	160	29.9	3,550	95		170	29.1	2,910	98		170	33.9	2,710	117
	170	22.7	3,080	75		180	22.1	2,500	77		180	28.4	2,300	100
	180	11.8	2,690	42		190	11.5	2,150	43		190	21.5	1,940	79
190' (57.9M)	35	80.7	19,320 *	193	200' (61.0M)	36	80.9	16,750 *	203		200	11.2	1,560 *	44
	40	79.2	18,660 *	192		40	79.7	16,230 *	202					
	50	76.1	17,360 *	190		50	76.8	15,000 *	200					

**With 47HI Boom, #9HL Jib and 58,100 Pound Counterweight**

Boom and Jib Length	Jib Radius (Feet)	5.0 Deg Offset		15.0 Deg Offset		25.0 Deg Offset		Boom and Jib Length	Jib Radius (Feet)	5.0 Deg Offset		15.0 Deg Offset		25.0 Deg Offset	
		Boom Angle	Ratings (Pounds)	Boom Angle	Ratings (Pounds)	Boom Angle	Ratings (Pounds)			Boom Angle	Ratings (Pounds)	Boom Angle	Ratings (Pounds)	Boom Angle	Ratings (Pounds)
40' (12.2M) JIB & 100' (30.5M) BOOM	30	80.7	22,550*					40' (12.2M) JIB & 140' (42.7M) BOOM	36	80.8	20,660*				
	35	78.6	22,550*						40	79.5	20,290*				
	40	76.5	22,270*	79.2	21,040*				50	76.3	19,360*	78.4	17,140*	80.4	13,940*
	50	72.2	21,530*	74.9	20,440*	77.5	19,530*		60	73.0	18,380*	75.1	16,530*	77.0	13,730*
	60	67.9	19,790	70.5	19,790	73.0	19,110*		70	69.6	15,440	71.7	15,440	73.6	13,330*
	70	63.4	16,210	66.0	16,220	68.4	16,220		80	66.2	12,840	68.2	12,840	70.1	12,840
	80	58.7	13,610	61.2	13,610	63.6	13,620		90	62.6	10,870	64.7	10,870	66.5	10,870
40' (12.2M) JIB & 110' (33.5M) BOOM	90	53.7	11,640	56.2	11,640	58.4	11,650	100	59.0	9,310	61.0	9,320	62.7	9,320	
	100	48.4	10,100	50.8	10,100	52.9	10,100	110	55.1	8,060	57.1	8,070	58.8	8,070	
	31	80.9	22,530*					120	51.1	7,030	53.1	7,040	54.7	7,040	
	35	79.3	22,530*					130	46.9	6,180	48.8	6,180	50.3	6,180	
	40	77.4	22,380*	79.9	21,070*			140	42.3	5,440	44.1	5,440	45.5	5,450	
	50	73.5	21,690*	76.0	20,550*	78.3	19,620*	40' (12.2M) JIB & 150' (45.7M) BOOM	37	81.0	17,540*				
	60	69.4	19,590	71.9	19,590	74.2	19,200*	40	80.1	17,270*					
40' (12.2M) JIB & 120' (36.6M) BOOM	70	65.3	16,020	67.7	16,020	70.0	16,020	50	77.0	16,390*	79.0	14,570*	80.9	11,850*	
	80	61.0	13,420	63.4	13,420	65.6	13,420	60	73.9	15,480*	75.9	13,950*	77.7	11,580*	
	90	56.5	11,440	58.9	11,440	61.0	11,440	70	70.7	14,620*	72.7	13,330*	74.5	11,160*	
	100	51.7	9,890	54.1	9,890	56.1	9,890	80	67.5	12,640	69.4	12,640	71.2	10,710*	
	110	46.6	8,640	48.9	8,640	50.8	8,640	90	64.2	10,670	66.1	10,670	67.8	10,200*	
	33	80.7	22,520*					100	60.8	9,120	62.7	9,120	64.4	9,120	
	35	80.0	22,520*					110	57.2	7,870	59.1	7,870	60.7	7,870	
40' (12.2M) JIB & 130' (39.6M) BOOM	40	78.2	22,500*	80.6	21,220*			120	53.5	6,840	55.4	6,840	57.0	6,840	
	50	74.5	21,840*	76.9	20,640*	79.1	19,450*	130	49.7	5,970	51.5	5,970	53.0	5,970	
	60	70.8	19,400	73.1	19,400	75.3	19,290*	140	45.5	5,240	47.3	5,240	48.7	5,250	
	70	66.9	15,820	69.2	15,820	71.4	15,830	150	41.1	4,620	42.8	4,620	44.1	4,620	
	80	62.9	13,220	65.2	13,220	67.3	13,220	40 (12.2M) JIB & 160' (48.8M) BOOM	39	80.9	14,880*				
	90	58.8	11,240	61.1	11,240	63.1	11,240	40	80.6	14,800*					
	100	54.5	9,690	56.7	9,690	58.7	9,690	50	77.7	13,940*	79.6	12,410*			
40' (12.2M) JIB & 130' (39.6M) BOOM	110	49.9	8,440	52.1	8,440	53.9	8,440	60	74.7	13,080*	76.6	11,810*	78.4	9,770*	
	120	45.0	7,410	47.1	7,420	48.8	7,420	70	71.7	12,280*	73.6	11,240*	75.3	9,380*	
	34	80.9	22,500*					80	68.7	11,520*	70.5	10,610*	72.2	8,910*	
	35	80.6	22,500*					90	65.6	10,480	67.4	10,000*	69.1	8,440*	
	40	78.9	22,500*					100	62.4	8,930	64.2	8,930	65.8	7,940*	
	50	75.4	21,960*	77.7	20,260*	79.8	16,510*	110	59.1	7,680	60.9	7,680	62.4	7,460*	
	60	71.9	19,220	74.1	19,220	76.2	16,330*	120	55.6	6,650	57.4	6,650	58.9	6,650	
70	68.3	15,640	70.5	15,640	72.5	15,640	130	52.1	5,790	53.8	5,790	55.3	5,790		
40' (12.2M) JIB & 130' (39.6M) BOOM	80	64.7	13,030	66.8	13,040	68.8	13,040	140	48.3	5,060	50.0	5,060	51.4	5,070	
	90	60.9	11,060	63.0	11,060	64.9	11,070	150	44.3	4,440	46.0	4,440	47.3	4,440	
	100	56.9	9,510	59.0	9,510	60.8	9,520	160	40.0	3,890	41.6	3,890	42.8	3,900	
	110	52.7	8,260	54.8	8,260	56.6	8,270								
	120	48.3	7,230	50.4	7,240	52.0	7,240								
	130	43.6	6,380	45.5	6,380	47.1	6,380								

**LIFT RATINGS IN POUNDS (continued)**

**With 47HI Boom, #9HL Jib and 58,100 Pound Counterweight (continued)**

Boom and Jib Length	Jib Radius (Feet)	5.0 Deg Offset		15.0 Deg Offset		25.0 Deg Offset	
		Boom Angle	Ratings (Pounds)	Boom Angle	Ratings (Pounds)	Boom Angle	Ratings (Pounds)
50' (15.2M) JIB & 130' (39.6M) BOOM	37	80.8	21,560*				
	40	79.8	21,560*				
	50	76.5	21,230*	79.2	18,440*		
	60	73.2	19,260	75.9	18,050*	78.3	14,500*
	70	69.9	15,670	72.5	15,670	74.9	14,320*
	80	66.4	13,070	69.0	13,070	71.4	13,070
	90	62.9	11,100	65.5	11,100	67.8	11,100
	100	59.2	9,540	61.8	9,550	64.0	9,550
50' (15.2M) JIB & 140' (42.7M) BOOM	110	55.4	8,290	57.9	8,300	60.1	8,300
	120	51.4	7,260	53.8	7,270	55.9	7,270
	130	47.1	6,410	49.5	6,410	51.5	6,410
	38	80.9	19,100*				
	40	80.3	19,090*				
	50	77.3	18,270*	79.8	15,660*		
	60	74.2	17,330*	76.6	15,230*	79.0	12,250*
	70	71.0	15,480	73.5	14,660*	75.8	12,030*
50' (15.2M) JIB & 150' (45.7M) BOOM	80	67.8	12,870	70.2	12,870	72.5	11,660*
	90	64.4	10,890	66.9	10,890	69.1	10,890
	100	61.0	9,340	63.4	9,340	65.6	9,340
	110	57.5	8,090	59.9	8,090	62.0	8,090
	120	53.8	7,060	56.1	7,060	58.2	7,060
	130	49.9	6,200	52.2	6,200	54.2	6,200
	140	45.8	5,470	48.0	5,470	49.9	5,480
	40	80.8	16,350*				
50' (15.2M) JIB & 160' (48.8M) BOOM	50	77.9	15,500*	80.3	13,360*		
	60	75.0	14,620*	77.3	12,930*	79.6	10,360*
	70	72.0	13,810*	74.3	12,350*	76.5	10,130*
	80	68.9	12,680	71.3	11,790*	73.4	9,780*
	90	65.8	10,690	68.1	10,700	70.2	9,390*
	100	62.6	9,140	64.9	9,140	67.0	8,960*
	110	59.3	7,890	61.6	7,890	63.6	7,890
	120	55.9	6,860	58.1	6,860	60.1	6,860
50' (15.2M) JIB & 170' (51.8M) BOOM	130	52.3	6,000	54.5	6,000	56.4	6,010
	140	48.5	5,270	50.7	5,270	52.5	5,280
	150	44.5	4,650	46.7	4,650	48.4	4,650
	41	81.0	13,930*				
	50	78.5	13,220*	80.8	11,420*		
	60	75.7	12,420*	78.0	10,970*	80.1	8,790*
	70	72.9	11,620*	75.1	10,460*	77.2	8,530*
	80	70.0	10,910*	72.2	9,900*	74.3	8,170*
50' (15.2M) JIB & 180' (54.9M) BOOM	90	67.0	10,200*	69.2	9,370*	71.3	7,790*
	100	64.0	8,960	66.2	8,830*	68.2	7,370*
	110	60.9	7,710	63.1	7,710	65.0	6,950*
	120	57.7	6,680	59.9	6,680	61.8	6,550*
	130	54.4	5,810	56.5	5,810	58.4	5,820
	140	50.9	5,080	53.0	5,080	54.8	5,090
	150	47.3	4,470	49.3	4,470	51.0	4,470
	160	43.4	3,920	45.4	3,920	47.0	3,930
50' (15.2M) JIB & 190' (57.9M) BOOM	43	80.9	11,760*				
	50	79.0	11,240*				
	60	76.4	10,490*	78.5	9,290*	80.6	7,450*
	70	73.7	9,740*	75.8	8,800*	77.8	7,150*
	80	70.9	9,090*	73.1	8,250*	75.0	6,780*
	90	68.1	8,440*	70.3	7,730*	72.2	6,400*
	100	65.3	7,840*	67.4	7,250*	69.3	6,010*
	110	62.4	7,290*	64.4	6,740*	66.3	5,600*
	120	59.4	6,470	61.4	6,280*	63.2	5,220*
	130	56.3	5,610	58.3	5,620	60.1	4,840*
	140	53.0	4,880	55.1	4,890	56.8	4,450*
150	49.7	4,260	51.6	4,260	53.3	4,070*	
160	46.1	3,720	48.1	3,720	49.6	3,700*	
170	42.3	3,240	44.2	3,250	45.7	3,250	

Boom and Jib Length	Jib Radius (Feet)	5.0 Deg Offset		15.0 Deg Offset		25.0 Deg Offset	
		Boom Angle	Ratings (Pounds)	Boom Angle	Ratings (Pounds)	Boom Angle	Ratings (Pounds)
60' (18.3M) JIB & 150' (45.7M) BOOM	42	80.9	15,270*				
	50	78.7	14,640*				
	60	75.9	13,810*	78.7	11,900*		
	70	73.1	13,030*	75.8	11,450*	78.3	9,070*
	80	70.2	12,320*	72.9	10,950*	75.4	8,860*
	90	67.3	10,730	69.9	10,420*	72.4	8,540*
	100	64.3	9,160	66.9	9,170	69.3	8,220*
	110	61.2	7,910	63.8	7,910	66.1	7,830*
	120	58.0	6,880	60.6	6,880	62.9	6,890
	130	54.6	6,020	57.2	6,020	59.4	6,030
	140	51.2	5,290	53.7	5,300	55.9	5,300
150	47.5	4,670	50.0	4,670	52.1	4,670	
60' (18.3M) JIB & 160' (48.8M) BOOM	44	80.8	12,930*				
	50	79.3	12,460*				
	60	76.6	11,740*	79.2	10,100*		
	70	73.9	11,020*	76.5	9,660*	78.9	7,700*
	80	71.1	10,310*	73.7	9,200*	76.1	7,440*
	90	68.4	9,670*	70.9	8,730*	73.3	7,110*
	100	65.5	8,990	68.0	8,270*	70.4	6,790*
	110	62.6	7,740	65.1	7,740	67.4	6,440*
	120	59.6	6,700	62.1	6,710	64.3	6,070*
	130	56.5	5,840	58.9	5,850	61.1	5,710*
	140	53.3	5,100	55.7	5,110	57.8	5,110
150	49.9	4,490	52.3	4,490	54.3	4,490	
160	46.3	3,940	48.7	3,940	50.6	3,950	
60' (18.3M) JIB & 170' (51.8M) BOOM	45	81.0	11,020*				
	50	79.7	10,620*				
	60	77.2	9,940*	79.7	8,590*		
	70	74.6	9,250*	77.1	8,170*	79.4	6,460*
	80	72.0	8,600*	74.5	7,710*	76.8	6,190*
	90	69.4	8,020*	71.8	7,230*	74.1	5,870*
	100	66.6	7,430*	69.1	6,790*	71.3	5,530*
	110	63.9	6,910*	66.3	6,340*	68.5	5,190*
	120	61.1	6,400*	63.4	5,920*	65.6	4,850*
	130	58.1	5,640	60.5	5,500*	62.6	4,520*
	140	55.1	4,910	57.5	4,910	59.5	4,180*
150	52.0	4,280	54.3	4,280	56.3	3,850*	
160	48.7	3,740	51.0	3,740	52.9	3,530*	
170	45.2	3,260	47.5	3,270	49.3	3,190*	



# AMERICAN MODEL HC 80 GENERAL DIMENSIONS

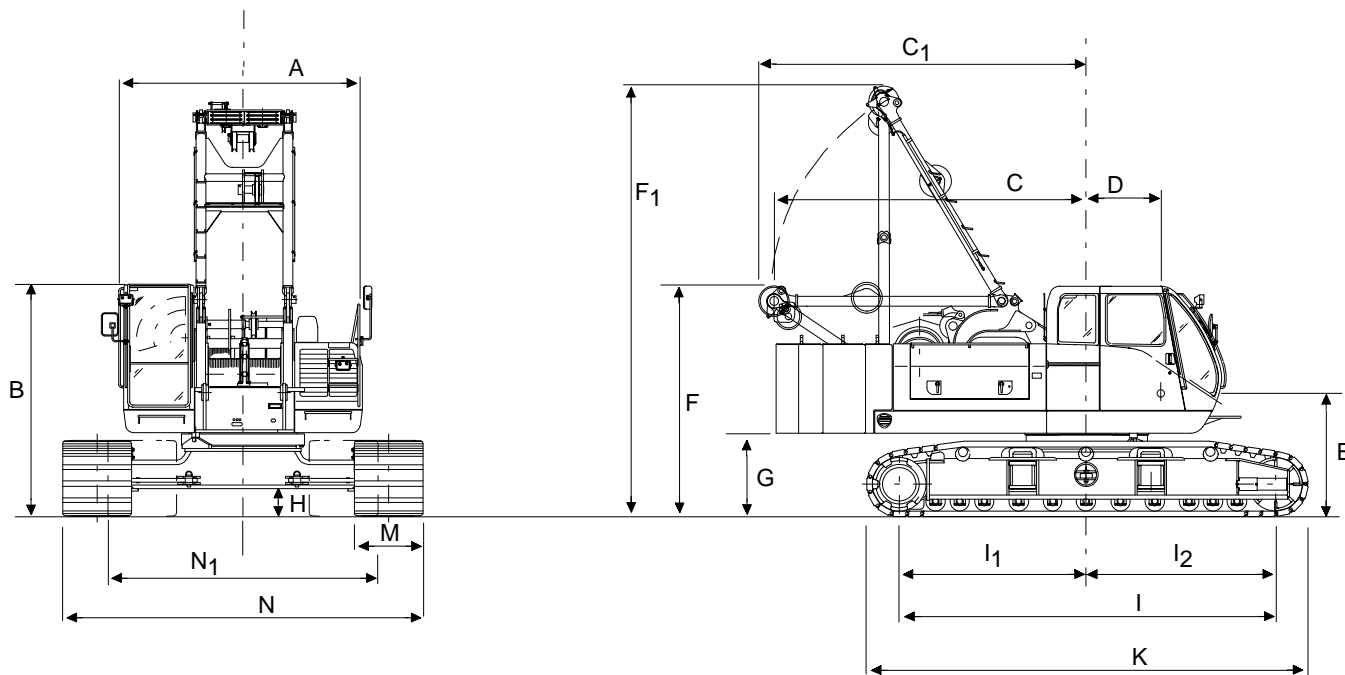

	FEET	MM		FEET	MM		
A	Width of machinery cab	10'-5 3/16"	3,180	I	Center to center of crawler tumbler	16'-7 1/4"	5060
B	Height over operator's cab	10'-1 1/14"	3,080	I <sub>1</sub>	Center of drive tumbler to center of rotation	8'-3 1/4"	2,520
C	Tail swing	13'-8 3/8"	4,175	I <sub>2</sub>	Center of idler tumbler to center of rotation	8'-4"	2,540
C <sub>1</sub>	Tail swing with A-Frame lowered	14'-5 1/4"	4,400	K	Overall length of crawlers	19'-5 7/8"	5,940
D	Center rotation to boom foot	3'-3 3/8"	1,000	M	Width of tread shoe (standard)	36"	915
E	Ground to center of boom foot	5'-5"	1,650	N	Overall width of crawler Shoes Extended	15'-9"	4,800
F	Height over A-Frame lowered	10'-1 5/8"	3,090	N <sub>1</sub>	Shoes Retracted	11'-9 3/4"	3,600
F <sub>1</sub>	Height over A-Frame raised	18'-0 15/16"	5,510				
G	Ground to bottom of counterweight	3'-7 7/8"	1,115				
H	Minimum ground clearance	1'-2 9/16"	370				

## TRANSPORT LOADS - HC 80 MACHINE, 170' 47HI BOOM AND 60' #9HL JIB

Load 1	Weight	Load 2*	Weight	Load 3*	Weight
Basic upper Including: Carbody, 47HI Boom Inner & Side Frames	88,000lbs (39,917kg)	47H 30' Boom Center	2,045lbs (928kg)	Outside Counterweight	21,000lbs (9,526kg)
		Inside Counterweight	16,000lbs (7,258kg)	47HI Boom Outer	2,225lbs (1,009kg)
		47H 30' Boom Center	2,045lbs (928kg)	47H 30' Boom Center	2,045lbs (928kg)
		#9HL 20' Jib Center	385lbs (175kg)	#9HL Jib Inner	890lbs (404kg)
		47H 30' Boom Center	2,045lbs (928kg)	#9HL Jib Outer	665lbs (303kg)
		Center Counterweight	21,000lbs (9,526kg)	Crate: Misc. Parts Block & Ball	3,500lbs (1588kg)
		47H 10' Boom Center	700lbs (318kg)		
Total Weights	88,000lbs (39,917kgs)		44,220lbs (20,058kg)		30,325lbs (13,755kg)

\*Loads based on 48 ft flatbed trailer.  
Loading information above is an example only, specific loads will vary depending on crane options.

## SHIPPING DATA

**Basic Crane with 47HI Inner**

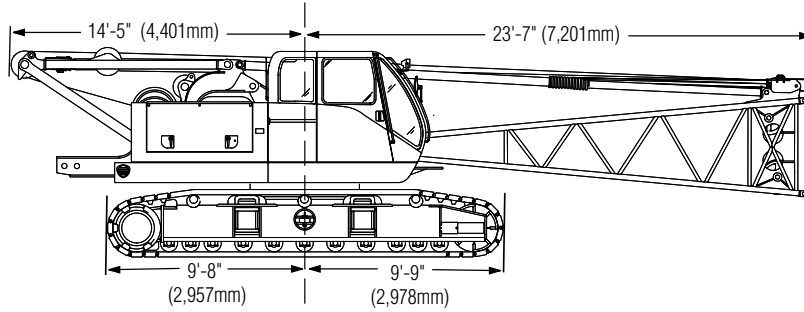

**47HI Boom Outer**

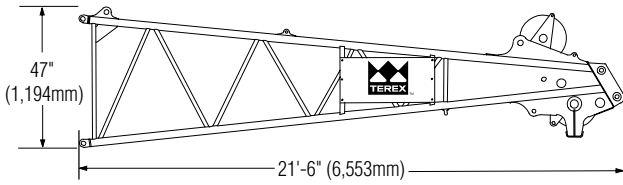

**Counterweight**

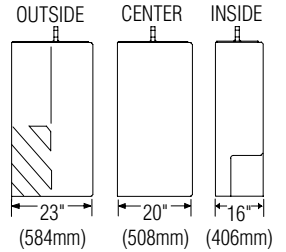
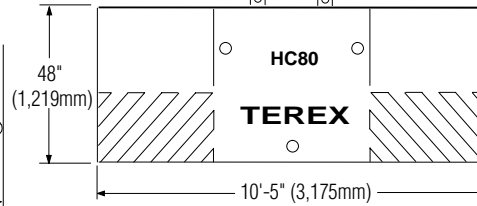

**47HI Boom Inner**

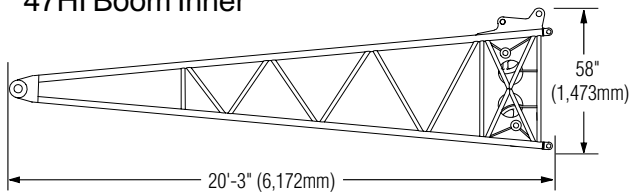

**#9HL Jib**

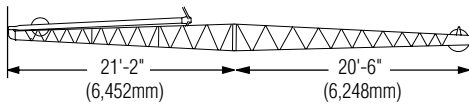

## COMPONENT WEIGHTS

	LBS.	KGS.
Basic Upper, Carbody, Boom Inner and Side Frames .....	88,000	39,917
Counterweight - Total .....	58,000	26,309
Inside Counterweight .....	16,000	7,258
Center Counterweight .....	21,000	9,526
Outside Counterweight .....	21,000	9,526
Boom Inner 47HI .....	3,660	1,660
Boom Outer 47HI .....	2,225	1,009
Boom Center Section with Pendants - 10 ft. - 47H ...	700	318
Boom Center Section with Pendants - 20 ft. - 47H ...	1,230	558
Boom Center Section with Pendants - 30 ft. - 47H ...	2,045	928
Jib Inner with Mast, 9HL .....	890	404
Jib Outer with Pendant, 9HL .....	665	303
Jib Center Section with Pendant, 10 ft. 9HL .....	190	87
Jib Center Section with Pendant, 20 ft. 9HL .....	385	175

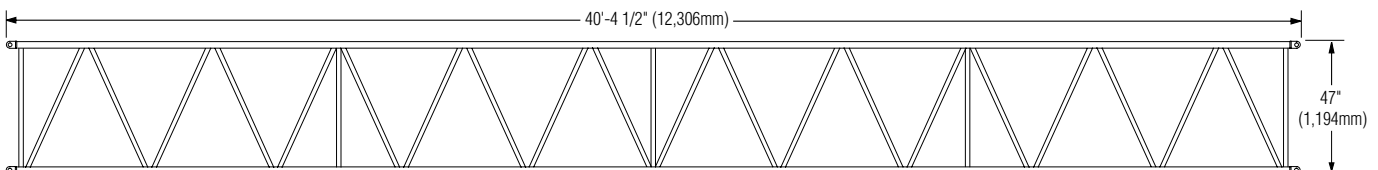
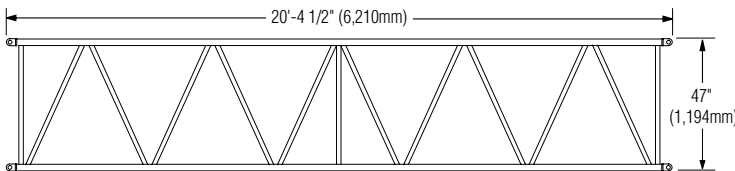
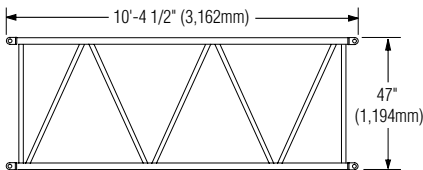

## BOOM COMPOSITION CHART

Boom Length Feet	Boom Sections				
	20' 47HI Inner	10' 47H Center	20' 47H Center	30' 47H Center	20' 47HI Outer
40	1	0	0	0	1
50	1	1	0	0	1
60	1	0	1	0	1
70	1	0	0	1	1
80	1	1	0	1	1
90	1	0	1	1	1
100	1	0	0	2	1
110	1	1	0	2	1
120	1	0	1	2	1
130	1	0	0	3	1
140	1	1	0	3	1
150	1	0	1	3	1
160	1	0	0	4	1
170	1	1	0	4	1
180	1	0	1	4	1
190	1	0	0	5	1
200	1	1	0	5	1

### #9HL Jib Composition

Jib Length Feet	20' Inner	10' Center	20' Center	20' Outer
40	1	0	0	1
50	1	1	0	1
60	1	0	1	1

## LOAD HOISTING INFORMATION

Maximum Lifting Capacity in Pounds	Minimum Parts of Line	Maximum Hoisting Dist. in Ft.
		Main & Auxiliary
160,000	8	73
159,180	7	84
136,440	6	98
113,700	5	117
90,960	4	147
68,220	3	196
45,480	2	294
22,740	1	588

## SPECIFICATIONS

Swing Speed ..... 3.30 RPM  
 Travel Speed ..... 1.24 MPH High Range  
 ..... 0.8 MPH Low Range  
 Gradeability ..... 40% (approximately 22°)

## GROUND PRESSURE

Lifting crane with 40' 47HI boom, standard counterweight  
 36" (914 mm) Shoes ..... 9.17 psi

## MAXIMUM BOOM & JIB SELF-ERECTION DATA

#9HL JIB	Over The End		Over The Side	
	Boom Length Ft.	Jib Length Ft.	Boom Length Ft.	Jib Length Ft.
	200	0	200	0
170	60	170	60	

## HC80 DRUM PERFORMANCE

### MAIN & AUXILIARY HOIST - 7/8" DIAMETER ROPE

Rope Layer	Low Range		High Range		Total Rope Length Ft.
	Line Speed Ft. per Min.	Single Line Pull Pounds**	Line Speed Ft. per Min.	Single Line Pull Pounds**	
1	258	32,400	337	24,400	81
2	279	29,900	365	22,500	174
3	300	27,900	392	21,000	268
4	321	26,000	420	19,600	375
5	336	24,500	447	18,400	482
6	363	23,000	474	17,300	603
7*	379	22,100	495	16,600	722
8*	407	20,500	532	15,430	860

\*RECOMMENDED FOR STORAGE ONLY

### 3rd DRUM WITH FREE FALL - 5/8" DIAMETER ROPE

Rope Layer	Load		No Load	
	Line Speed Ft. per Min.	Single Line Pull Pounds**	Line Speed Ft. per Min.	Total Rope Length Ft.
1	181	18,600	219	59
2	195	17,300	235	118
3	209	16,200	252	185
4	222	15,200	269	253
5	236	14,300	285	329
6	250	13,500	302	405
7	263	12,800	318	490
8	277	12,200	335	575
9	291	11,600	352	669
10	305	11,100	368	761
11*	317	10,590	384	835

\*RECOMMENDED FOR STORAGE ONLY

\*\*Single Line Pull reflects the maximum hydraulic capability of the hoist unit at the given layer and range setting. The allowable single line pull may be limited by the strength of the hoist rope. See load hoisting table for rope limitations.

## CRANE RATING DATA

### **WARNING**

**This rating is invalid if the crane has been modified or altered by use of other than GENUINE AMERICAN PARTS as such modifications or alterations may affect its capacity or safe operation. See American Crane Corporation Service Bulletin #259.**

**The ratings in this chart are for planning purposes only. Only those ratings specifically assigned to a crane and mounted in the operator's cab or in the Operator's Manual should be used for actual operation.**

Ratings in this chart are in POUNDS and do not exceed the percentage of tipping specified for this crane by ANSI B30.5. All ratings require that the crane be standing level on a firm uniformly supporting surface.

Do not lift loads in excess of those shown on this chart. Lifting loads in excess of those shown or operation not in accordance with good operating practice, including limitations shown on page 3499 of Operator's Manual, can cause tipping, structural damage or catastrophic failure.

Asterisk (\*) areas on this chart indicate ratings which are limited by strength of material or factors other than stability (tipping).

"RADIUS IN FEET" is the horizontal distance at ground level from the crane centerline of rotation to a vertical line through the center of gravity of the suspended load.

When using the main boom fall with jib in place, the main fall ratings must be reduced by the jib effective weight shown on the jib rating chart plus twice the weight of all suspended blocks, slings, rope, etc., at the jib fall.

When using the main boom fall with boom tip extension in place, the main fall ratings must be reduced by the weight of the boom tip extension plus twice the weight of all suspended blocks, slings, rope, etc., at the boom tip extension fall.

Blocks, slings, buckets and other load carrying devices are considered part of the load. The weight of standard hoisting ropes for the rating at a given radius has been calculated as part of the boom point load and need not be considered in determining net allowable loads.

Ratings shown on this chart make no allowance for such factors as out of plumb loads, wind, poor soil conditions, and dynamic effects due to excessive operating speeds. The user (operator) must exercise judgement to make allowance for these conditions. See page 3499 of Operator's Manual for detailed information.

No account is taken of the wind force on the load. This effect, which can be substantial for loads with large surface areas, must be considered by the user. In any wind it is strongly recommended that taglines be used to control the load.

BOOM HOIST LINE is 14 parts of 5/8 inch diameter EIPS wire rope with a minimum breaking strength of 41,200 pounds.

PENDANT SUSPENSION LINE is 2 parts of 1-1/4 inch diameter MONOLAY wire rope with a minimum breaking strength of 172,800 pounds.

MAIN AND AUXILIARY LOAD LINES are 7/8 inch diameter EIPS wire rope with a minimum breaking strength of 79,600 pounds.

THIRD DRUM LINE is 5/8 inch diameter IPS wire rope with a minimum breaking strength of 35,000 pounds.

Erection "OVER THE END" is with the boom over the idler end. Erection "OVER THE SIDE" is with the boom 90° to the side frames and with the side frames extended. Blocks, slings and other load carrying devices must be on the ground during erection.



# AMERICAN MODEL HC 80 WORKING RANGES WITH 47HI BOOM

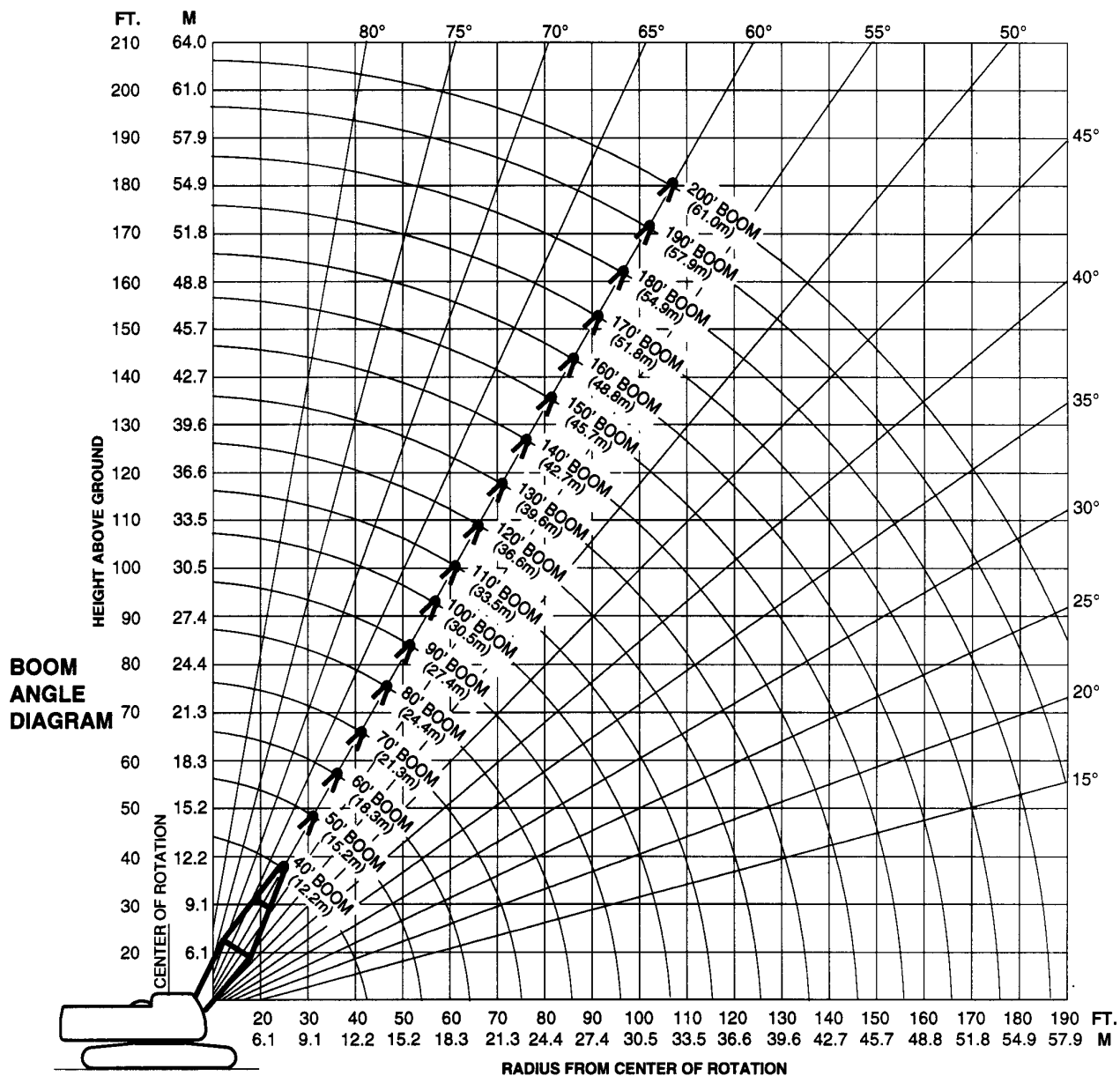

For more information, product demonstration, or details on sales, lease and rental plans, please contact your local Terex American Crane Distributor.

We reserve the right to amend these specifications at any time without notice. The only warranty applicable is our standard written warranty applicable to the particular product and sale. We make no other warranty, expressed or implied.

**Bigge Crane and Rigging Co.**

10700 Bigge Avenue  
 San Leandro, CA 94577  
 Phone: (888) 337-BIGGE or (510) 638-8100  
 Fax: (510) 639-4053  
 Email: info@bigge.com  
 Web site: www.bigge.com

**TEREX CRANES**

AMERICAN CRANE CORPORATION  
 202 Raleigh Street  
 Wilmington, NC 28412 USA  
 (910) 395-8500 • FAX: (910) 395-8538  
 E-mail: american@american-crane.com

