

GROVE

RT875E

**product
guide**

features

- 75 ton (68 mt) capacity
- 41 ft-128 ft (12.6 m-39.0 m)
4 section, full power boom
- 33 ft-56 ft (10.0 m-17.0 m)
offsettable lattice
swingaway extension
- 20 ft (6.1 m) or 40 ft (12.2 m)
extension inserts
- Grove MEGAFORM™ boom
- 18,000 lb (8 165 kg)
hydraulic removable
counterweight
- 275 bhp (205 kW) Tier III
Cummins diesel engine



contents

Features	2
Specifications	3
Dimensions	5
Working Range Bifold	6
Load Charts	7
Working Range Bifold & Inserts	8
Load Charts	10
Load Handling	11

Rough Terrain Hydraulic Crane



features

2



- The Grove MEGAFORM™ boom shape eliminates weight and increases capacity compared to conventional shapes.



- For improved operator comfort and visibility of the boom load the cab can be tilted up to 20°.



- Max. tip height of 232 ft. (70.6 m) w/56 ft. (17.0 m) bi-fold and (2) 20 ft. (6.1 m) inserts.

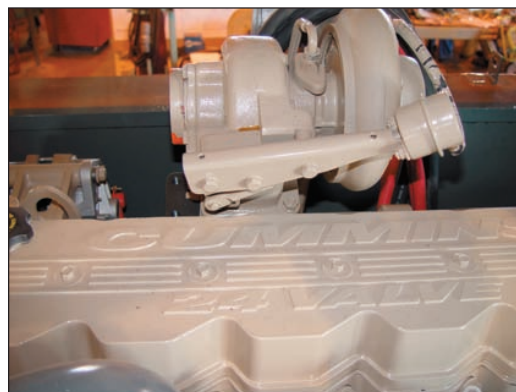

- Electronically controlled Cummins diesel engine provides plenty of power at the jobsite.



specifications

Superstructure



Boom

41 ft. - 128 ft. (12.6 m - 39.0 m) four-section, sequenced synchronized full power boom. Maximum tip height: 138 ft. (41.9 m).



Lattice Extension

33 ft.-56 ft. (10.0 m-17 m) offsettable bifold lattice swingaway extension. Offsets 0°, 20°, and 40°. Stows alongside base boom section. Maximum tip height: 192 ft. (58.6 m).



*Optional Lattice Extension Inserts

(2) x 20 ft. (6.1 m) lattice extension inserts. Installs between the boom nose and bifold extension, non-stowable. Maximum tip height: 232 ft. (70.6 m).



Boom Nose

Four nylatron sheaves mounted on heavy-duty tapered roller bearings with removable pin-type rope guards. Quick-reeving type boom nose. Removable auxiliary boom nose with removable pin type rope guard.



Boom Elevation

One double-acting hydraulic cylinder with integral holding valve provides elevation from -3° to +78°.



Load Moment & Anti-Two Block System

Standard "Graphic Display" load moment and anti-two block system with audio-visual warning and control lever lockout. These systems provide electronic display of boom angle, length, radius, tip height, relative load moment, maximum permissible load, load indication and warning of impending two-block condition. The standard Work Area Definition System allows the operator to pre-select and define safe working areas. If the crane approaches the pre-set limits, audio-visual warnings aid the operator in avoiding job-site obstructions.



Cab

Full-vision, all-steel fabricated with acoustical lining and tinted safety glass throughout. Cab tilts to +20 degrees. Deluxe seat incorporates armrest-mounted hydraulic single-axis controllers. Dash panel incorporates gauges for all engine functions. Other standard features include: hot water heater, cab circulating air fan, sliding side and rear windows, sliding skylight with electric wiper and sunscreen, electric windshield wash/wipe, fire extinguisher and seat belt.



Swing

Two speed, planetary swing drive with foot-applied multi-disc wet brake. Spring applied, hydraulically-released swing brake. Single position mechanical house lock, operated from cab. Maximum speed: 2.0 RPM.



Counterweight

18,000 lbs. (8 165 kg). Hydraulically installed and removed.



Hydraulic System

Two main pumps ([1] piston and [1] gear) with a combined capacity of 133 GPM (503 LPM). Maximum operating pressure: 4000 psi (277.7 bar). Three section pressure compensated valve bank. Return line type filter with full flow by-pass protection and service indicator. Replaceable cartridge with micron filtration rating of 5/12/16. 263 gallon (995 L) hyd. reservoir. Carrier mounted oil cooler with thermostatically controlled hydraulic motor driven fan/air to oil. System pressure test ports.



Hoist Specifications (HP30-19G) Main and Auxiliary Hoist

Planetary reduction with automatic spring applied multi-disc wet brake. Electronic hoist drum rotation indicators and hoist drum cable followers.

Maximum Single Line Pull:

1st layers: 20,250 lb. (9 185 kg)

3rd layer: 17,010 lb. (7 715 kg)

5th layer: 14,660 lb. (6 650 kg)

Maximum Permissible Line Pull:

16,800 lb. (7 620 kg) with 6 x 37 class rope

16,800 lb. (7 620 kg) with 35 x 7 class rope

Maximum Single Line Speed: 514 FPM (156 m/min)

Rope Construction:

6 x 36 EIPS IWRC, Special Flexible

35 x 7 Flex-X, Rotation Resistant

Rope Diameter: 3/4" (19 mm)

Rope Length:

Main Hoist: 600 ft. (182.8 m)

Auxiliary Hoist: 600 ft. (182.8 m)

Maximum Rope Stowage:

841 ft. (256 m)

**Denotes optional equipment*

3

RT875E

GROVE



specifications

4

Carrier

Chassis

Box section frame fabricated from high-strength, low alloy steel. Front/rear towing and tie down lugs.

Outrigger System

Four hydraulic telescoping single-stage double box beam outriggers with inverted jacks and integral holding valves. Three position setting, 0%, 50% and fully extended. All steel fabricated, quick-release type round outrigger floats, 30.5 in. (775 mm) diameter. Maximum outrigger pad load: 125,000 lb. (56 700 kg).

Outrigger Controls

Controls and crane level indicator located in cab.

Engine (Tier III)

Cummins QSB 6.7L diesel, six cylinders, 275 bhp (205 kW) (Gross) @ 2,500 rpm. Maximum torque: 728 ft. lbs. (987 Nm) @ 1,500 RPM.

Fuel Tank Capacity

72 gallons (273 L)

Transmission

Full rangeshift with 6 forward and 6 reverse speeds. Front axle disconnect for 4 x 2 travel.

Electrical System

Two 12-V maintenance free batteries. 12-V starting and lighting. Battery disconnect. CanBus Diagnostic system.

Drive

4 x 4

Steering

Fully independent power steering:

Front: Full hydraulic, steering wheel controlled.

Rear: Full hydraulic, switch controlled.

Provides infinite variations of 4 main steering modes: front only, rear only, crab and coordinated.

Rear steer indicator.

Turning radius - 25 ft.

Axles

Front: Drive/steer with differential and planetary reduction hubs rigid-mounted to frame.

Rear: Drive/steer with differential and planetary reduction hubs pivot-mounted to frame.

Oscillation Lockouts

Automatic full hydraulic lockouts on rear axle permits 10 in. (25.4 cm) oscillation only with boom centered over the front.

Brakes

Full hydraulic split circuit brakes operating on all wheels. Spring-applied, hydraulically released parking brake mounted on front axle.

Tires

Std. 29.5 x 25 - 34 bias ply, General.

Lights

Full lighting including turn indicators, head, tail, brake and hazard warning lights.

Maximum Speed

22 MPH (35 kph).

Gradeability (Theoretical)

75% (Based on 108,158 lb. [49 060 kg] GVW) 29.5 x 25 tires, 128 ft. (39.0 m) boom, plus 56 ft. (17.0 m) swingaway, 18,000 lb. (8 165 kg) counterweight, 75T hookblock and 10T headache ball).

Miscellaneous Standard Equipment

Full width steel fenders, full length aluminum decking, dual rear view mirrors, hookblock tiedown, electronic back-up alarm, light package, front stowage well, tachometer/hourmeter, rear wheel position indicator, 36,000 BTU hot water cab heater, hoist mirrors, engine distress A/V warning system, front/rear tie down and two lugs, coolant sight level indicator.

*Optional Equipment

*Auxiliary Lighting Package (includes cab mounted amber flashing light, hoist mounted work light, and dual base boom mounted floodlights.)

*LMI light bar (in cab)

*Air Conditioning (28,500 BTU)

*360 degree NYC style mechanical swinglock

*Rear Pintle hook

*Cab controlled cross axle differential locks, (front and rear)

*PAT data logger

*Rubber mat for stowage trough

**Denotes optional equipment*

RT875E

GROVE



dimensions

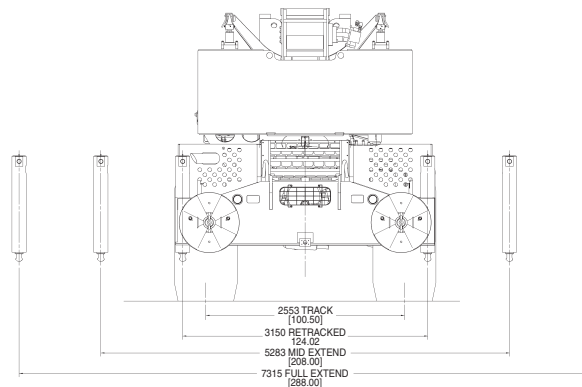
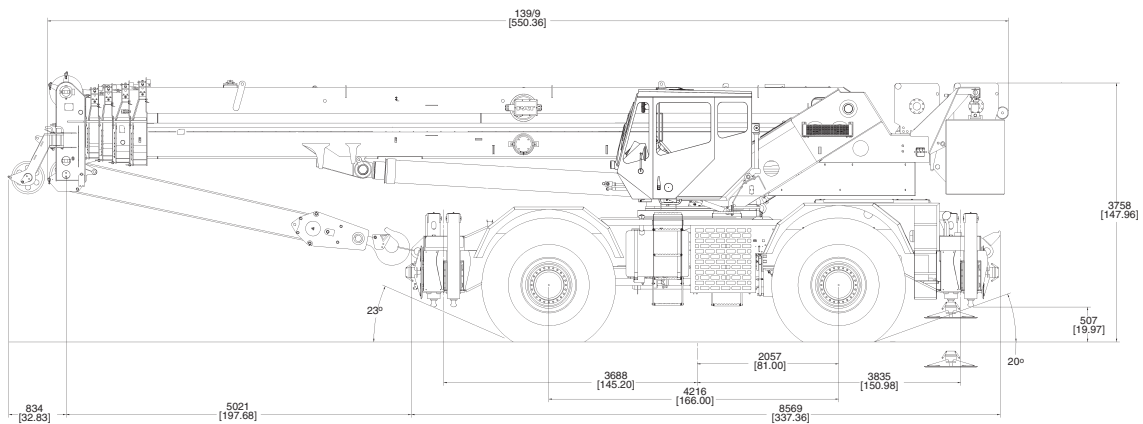
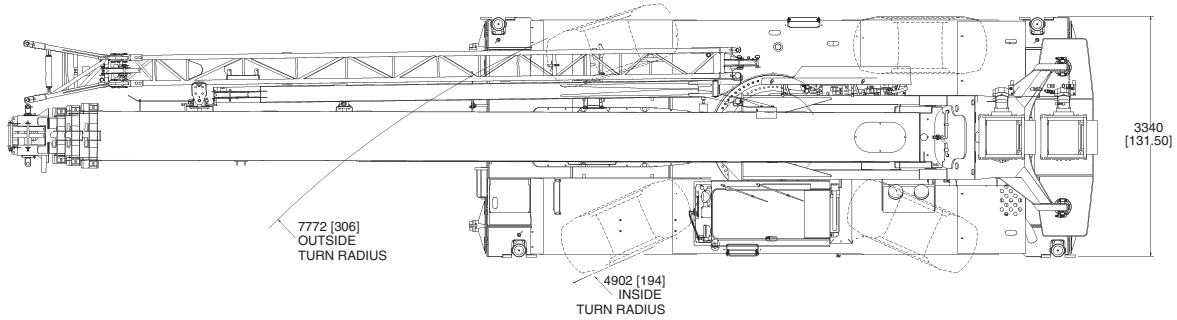

Note: Reference dimensions in mm [inches]

Weights

	GVW		Front		Rear	
	lb.	kg	lb.	kg	lb.	kg
RT875E Basic Machine						
Basic Machine including 128 ft. main boom, main and aux. hoist with 600 ft. of rope, 56' (17 m) bifold swingaway, full counterweight, 10T headache ball, and 75T hookblock:	108,158	49 060	53,888	24 444	54,270	24 617
Remove counterweight and aux. hoist. 56' (17 m) bifold.	87,917	39 879	63,520	28 813	24,397	11 066
Remove counterweight, aux. hoist, and 56' (17 m) bifold swingaway.	85,285	38 685	58,725	26 638	26,560	12 048

RT875E



working range

Working range diagram with bi-fold extension

6

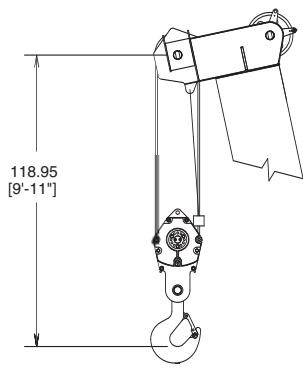
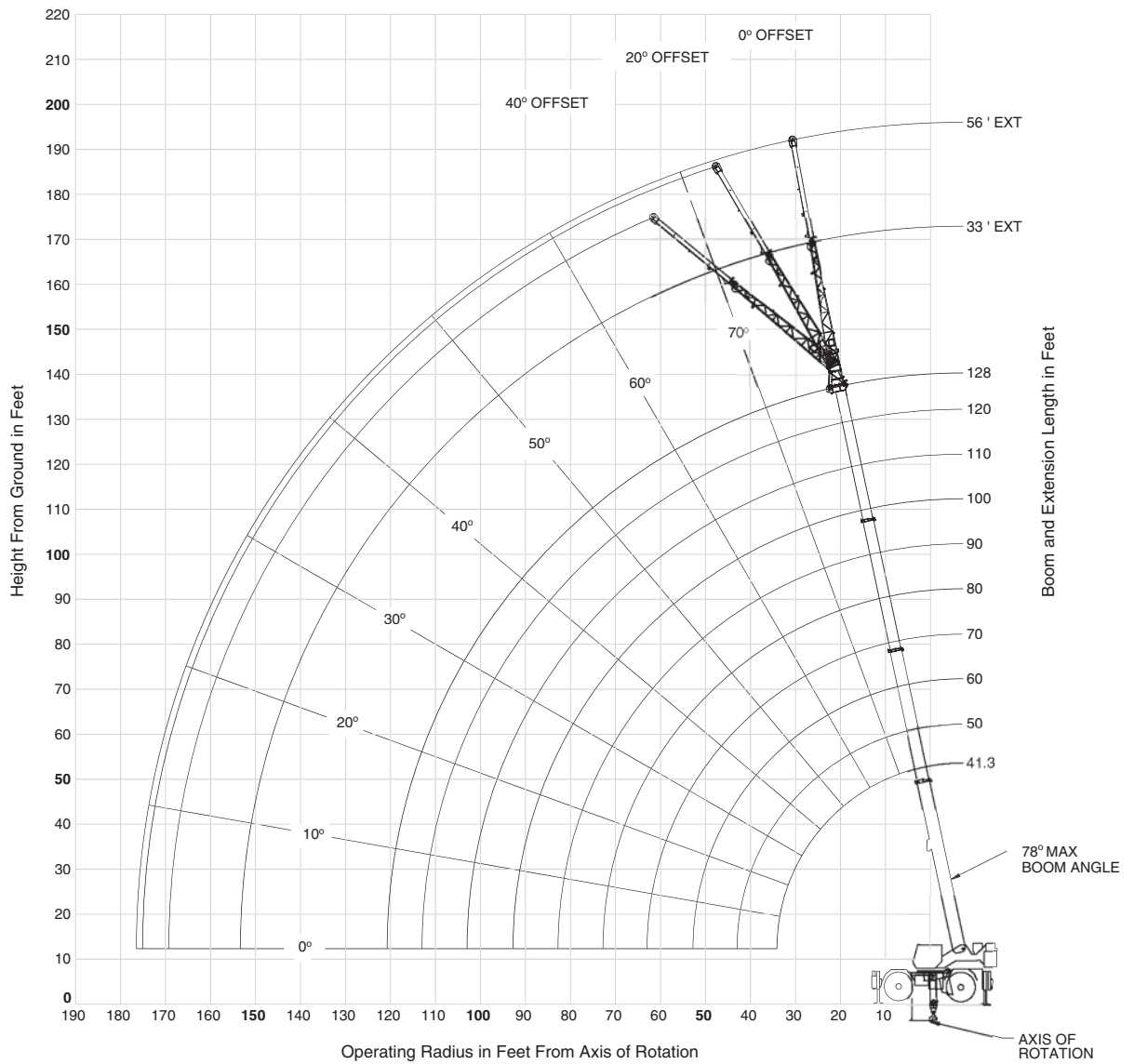

Dimensions are for largest Grove furnished hookblock and overhaul ball, with anti-two block activated.

RT875E

THIS CHART IS ONLY A GUIDE AND SHOULD NOT BE USED TO OPERATE THE CRANE. The individual crane's load chart, operating instructions and other instructional plates must be read and understood prior to operating the crane.



RT875E load chart

Feet	Main Boom Length in Feet											
	41.3	50	60	**70	80	90	100	110	120	128		
10	+150,000 (71)	124,000 (74.5)	105,500 (77.5)									
12	+150,000 (67.5)	124,000 (72)	105,500 (75.5)	59,500 (78)								
15	130,000 (63)	124,000 (68.5)	104,000 (72.5)	59,500 (73.5)	42,100 (78)	42,000 (79)						
20	100,000 (54.5)	99,850 (62)	85,900 (67.5)	59,500 (71)	42,100 (74)	42,000 (76)	*39,650 (78)	*31,950 (78)				
25	80,550 (44.5)	80,250 (55)	72,550 (62)	57,050 (68.5)	42,100 (70)	42,000 (73)	39,650 (75)	31,950 (77)	*25,750 (78)	*22,000 (79)		
30	59,050 (31.5)	58,150 (47)	57,850 (56)	49,300 (62)	42,100 (66)	39,050 (69.5)	36,150 (72)	31,950 (74)	25,750 (76)	22,000 (77)		
35	43,250 (37.5)	43,000 (49.5)	42,800 (57)	42,800 (66)	38,150 (62)	34,100 (68.5)	31,350 (71.5)	29,300 (73.5)	25,750 (74.5)	22,000 (74.5)		
40	33,600 (24.5)	33,400 (42.5)	32,950 (50)	32,950 (58)	33,750 (48.5)	30,050 (62)	27,500 (65.5)	25,850 (68.5)	23,900 (71.5)	22,000 (72.5)		
45	See Note 16	26,800 (34)	26,800 (46)	26,800 (53)	27,400 (58.5)	26,750 (62)	24,400 (65.5)	22,700 (68)	21,450 (70)	20,850 (70)		
50		21,600 (39.5)	21,150 (43)	21,150 (50)	22,450 (48.5)	23,250 (54.5)	21,850 (59)	20,250 (62.5)	19,100 (65.5)	18,350 (67.5)		
55		17,250 (31.5)	17,250 (43)	17,250 (50)	18,650 (48.5)	19,400 (54.5)	19,700 (55)	18,200 (59.5)	17,100 (63)	16,400 (65)		
60		14,200 (21)	14,200 (37)	14,200 (45)	15,600 (45.5)	16,400 (51.5)	17,050 (51.5)	16,450 (56)	15,450 (60)	14,750 (62.5)		
65		13,100 (29.5)	13,100 (40.5)	13,100 (47.5)	13,850 (47.5)	14,550 (53)	14,950 (53)	14,000 (57)	13,350 (59.5)	13,350 (59.5)		
70		11,050 (19)	11,050 (34.5)	11,050 (43)	11,800 (34.5)	12,450 (43)	12,900 (49.5)	12,700 (54)	12,000 (57)	11,050 (54)		
75		10,000 (29)	10,000 (38.5)	10,000 (45.5)	10,700 (38.5)	11,200 (45.5)	11,200 (51)	11,600 (51)	11,600 (54)	11,050 (54)		
80		8,540 (18)	8,540 (33)	8,540 (41.5)	9,170 (33)	9,670 (41.5)	9,670 (47.5)	10,150 (47.5)	10,150 (51)	10,100 (51)		
85		7,860 (25.5)	7,860 (37)	7,860 (44)	8,360 (37)	8,860 (44)	8,860 (49)	9,180 (49)	9,180 (54)	9,180 (54)		
90		6,710 (17.5)	6,710 (32)	6,710 (40)	7,210 (32)	7,700 (40)	7,700 (44.5)	8,050 (44.5)	8,050 (49)	8,050 (49)		
95		6,200 (25.5)	6,200 (35.5)	6,200 (41)	6,700 (35.5)	7,050 (41)	7,050 (47.5)	7,350 (47.5)	7,350 (51)	7,350 (51)		
100		5,310 (30.5)	5,310 (37)	5,310 (45.5)	5,900 (37)	6,160 (45.5)	6,160 (51)	6,160 (56)	6,160 (61)	6,160 (61)		
105		5,010 (32.5)	5,010 (42.5)	5,010 (50.5)	5,360 (42.5)	5,630 (50.5)	5,630 (56)	5,630 (61)	5,630 (66)	5,630 (66)		
110		4,290 (16.5)	4,290 (27.5)	4,290 (35.5)	4,940 (27.5)	5,300 (35.5)	5,300 (41.5)	5,300 (47.5)	5,300 (51)	5,300 (51)		
115		4,000 (21.5)	4,000 (31.5)	4,000 (39.5)	4,000 (31.5)	4,000 (39.5)	4,000 (45.5)	4,000 (51)	4,000 (56)	4,000 (56)		
120		3,410 (10.5)	3,410 (21.5)	3,410 (29.5)	3,410 (21.5)	3,410 (29.5)	3,410 (35.5)	3,410 (41.5)	3,410 (47.5)	3,410 (47.5)		

Minimum boom angle (deg.) for indicated length (no load)
 9
 Maximum boom length (ft.) at 0 deg. boom angle (no load)
 120
 #LMI operating code. Refer to LMI manual for instructions.
 *This capacity is based upon maximum obtainable boom angle.
 Note: () Boom angles are in degrees.
 *9 parts line required to lift this capacity (using aux. boom nose). Refer to Operator's & Safety Handbook for reeving diagram.
Lifting Capacities at Zero Degree Boom Angle

Boom Angle	Main Boom Length in Feet											
	41.3	50	60	**70	80	90	100	110	120			
0°	20,750 (34.1)	15,150 (42.8)	10,500 (52.8)	6,700 (63)	5,100 (72.8)	3,900 (82.8)	2,900 (82.8)	2,000 (102.8)	1,300 (112.8)			

Note: () Reference radii in feet.
 **This boom length is with inner-mid fully extended and outer-mid & fly fully retracted.

Feet	33 ft. LENGTH						56 ft. LENGTH					
	0°	20°	40°	0°	20°	40°	0°	20°	40°	0°	20°	40°
35	11,900 (78)											
40	11,900 (77)									6,060 (79)		
45	11,900 (75.5)	11,900 (78)								6,060 (77.5)		
50	11,900 (72.5)	10,600 (70.5)	9,790 (78)							6,060 (76)		
55	11,900 (71.5)	9,770 (74.5)	8,470 (77)							6,060 (74.5)		
60	11,000 (69.5)	9,020 (72.5)	7,920 (75)							6,060 (78)	6,060 (76)	
65	10,000 (67.5)	8,360 (70.5)	7,430 (73)							6,060 (71)	5,900 (76.5)	
70	9,190 (65.5)	7,780 (68.5)	6,980 (71)							6,060 (75)	5,730 (78)	5,060 (78)
75	8,480 (63.5)	7,280 (69.5)	6,580 (73)							6,060 (73.5)	5,330 (77)	4,640 (77)
80	7,820 (61.5)	6,790 (64.5)	6,210 (66.5)							6,040 (71.5)	4,980 (75.5)	4,370 (75.5)
85	7,250 (59.5)	6,370 (62.5)	5,870 (64.5)							5,570 (73)	4,650 (77)	4,120 (77)
90	6,740 (57)	5,980 (60)	5,560 (62)							5,150 (67.5)	4,380 (71.5)	3,890 (71.5)
95	6,290 (55)	5,640 (57.5)	5,280 (60)							4,780 (66)	4,090 (71.5)	3,680 (66)
100	5,980 (52.5)	5,320 (55.5)	5,020 (57.5)							4,440 (58.5)	3,840 (64)	3,480 (67.5)
105	5,510 (50)	5,030 (53)	4,770 (55)							4,130 (56.5)	3,610 (62)	3,300 (65.5)
110	5,170 (47.5)	4,780 (50.5)	4,550 (52)							3,850 (54.5)	3,400 (60)	3,130 (63.5)
115	4,830 (45)	4,510 (47.5)	4,340 (49.5)							3,590 (52.5)	3,200 (58)	2,970 (61)
120	4,230 (42)	4,280 (45.5)	4,150 (46.5)							3,360 (50.5)	3,020 (55.5)	2,820 (59)
125	3,690 (39)	3,690 (41.5)	3,560 (44)							3,140 (53.5)	2,840 (56.5)	2,680 (56.5)
130	3,200 (36)	3,430 (38.5)	3,430 (40)							2,940 (46)	2,690 (51)	2,540 (54)
135	2,740 (32)	2,930 (35)	2,930 (37)							2,760 (43.5)	2,540 (48.5)	2,420 (51.5)
140	2,320 (28)	2,480 (30.5)	2,480 (32)							2,590 (41)	2,400 (46)	2,300 (48.5)
145	1,940 (23)	2,030 (25.5)	2,030 (27)							2,430 (38.5)	2,270 (43.5)	2,140 (46.5)
150	1,580 (16.5)	1,580 (18.5)	1,580 (20.5)							2,070 (35.5)	2,140 (40.5)	2,030 (44.5)
155										1,730 (32.5)	2,030 (37)	1,910 (40.5)
160										1,420 (29)	1,710 (33.5)	1,600 (37.5)
165										1,120 (24.5)	1,420 (29.5)	1,310 (33.5)

Minimum boom angle (°) for indicated length (no load)
 15 28 44 23 31 46
 Maximum boom length (ft.) at 0° boom angle (no load)
 110 110
 NOTE: () Boom angles are in degrees.
 #LMI operating code. Refer to LMI manual for operating instructions.
 *This capacity is based upon maximum boom angle.

NOTES:

- All capacities above the bold line are based on structural strength of boom extension and do not exceed 85% of tipping loads, in accordance with SAE J-765.
- The 33 ft. extension length may be used with single or double part line lifting service. The 56 ft. extension length may be used for single line lifting service only.
- For main boom lengths less than 128 ft. with the boom extension erected, the rated loads are determined by boom angle. Use only the column which corresponds to the boom extension length and offset for which the machine is set up. For boom angles not shown, use the rating of the next lower boom angle.
- WARNING:** Operation of this machine with heavier loads than the capacities listed is strictly prohibited. Machine tipping with boom extension occurs rapidly and without advance warning.
- Boom angle is the angle above or below horizontal of the longitudinal axis of the boom base section after lifting rated load.
- Capacities listed are with outriggers properly extended and vertical jacks set only.
- When lifting over the main boom nose with 33 ft. or 56 ft. extension erected, the outriggers must be fully extended or 50% extended (17 ft. 4 in. spread).

THIS CHART IS ONLY A GUIDE AND SHOULD NOT BE USED TO OPERATE THE CRANE. The individual crane's load chart, operating instructions and other instructional plates must be read and understood prior to operating the crane.

RT875E

working range

Working range diagram with bi-fold extension and one insert

8

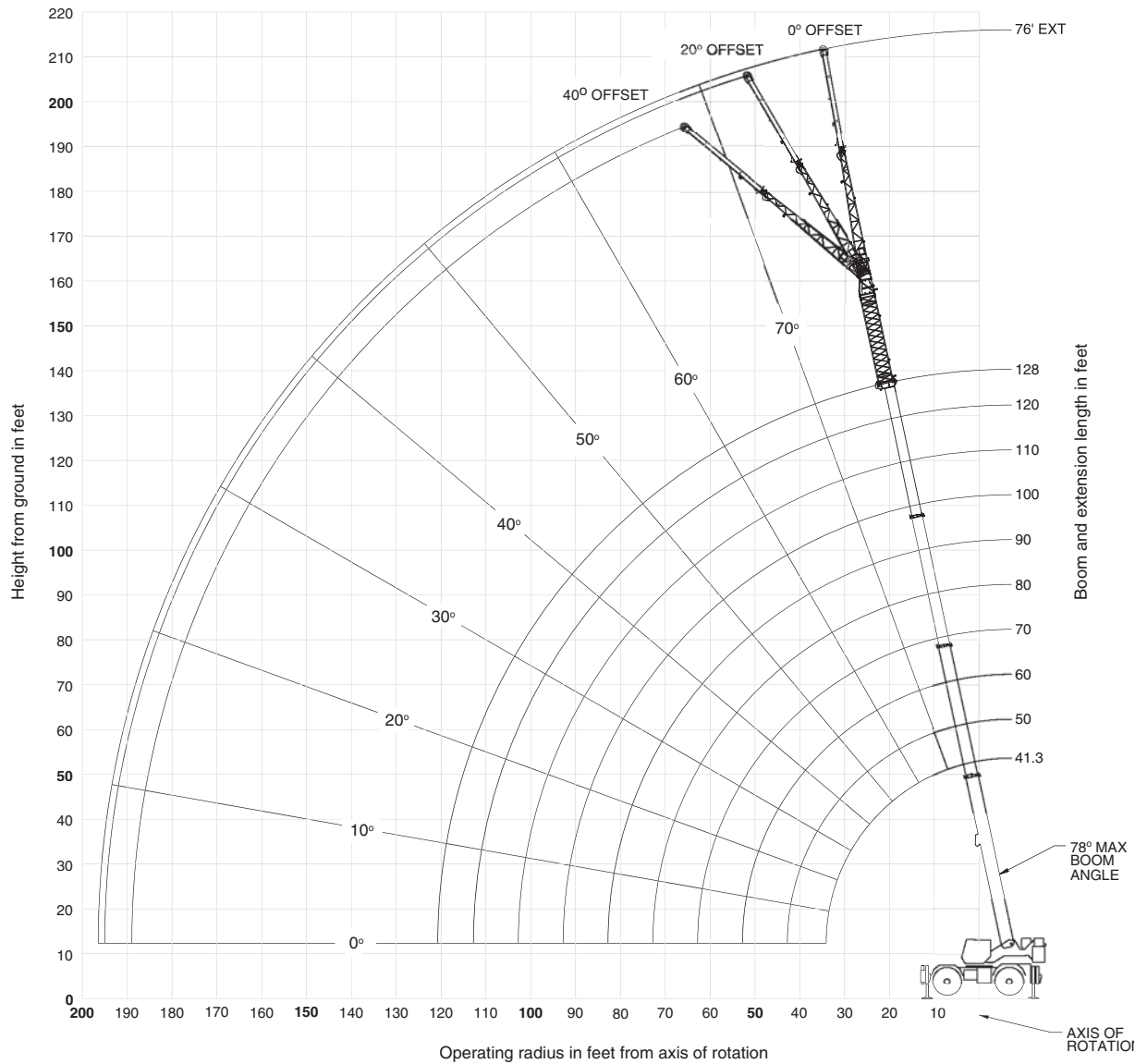

RT875E

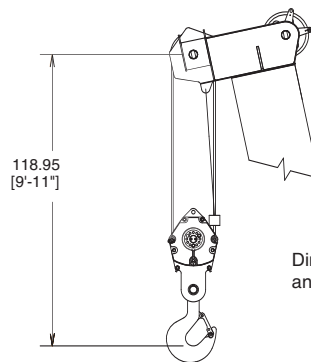

Dimensions are for largest Grove furnished hookblock and overhaul ball, with anti-two block activated.

THIS CHART IS ONLY A GUIDE AND SHOULD NOT BE USED TO OPERATE THE CRANE. The individual crane's load chart, operating instructions and other instructional plates must be read and understood prior to operating the crane.

GROVE



working range

Working range diagram with bi-fold extension and two inserts

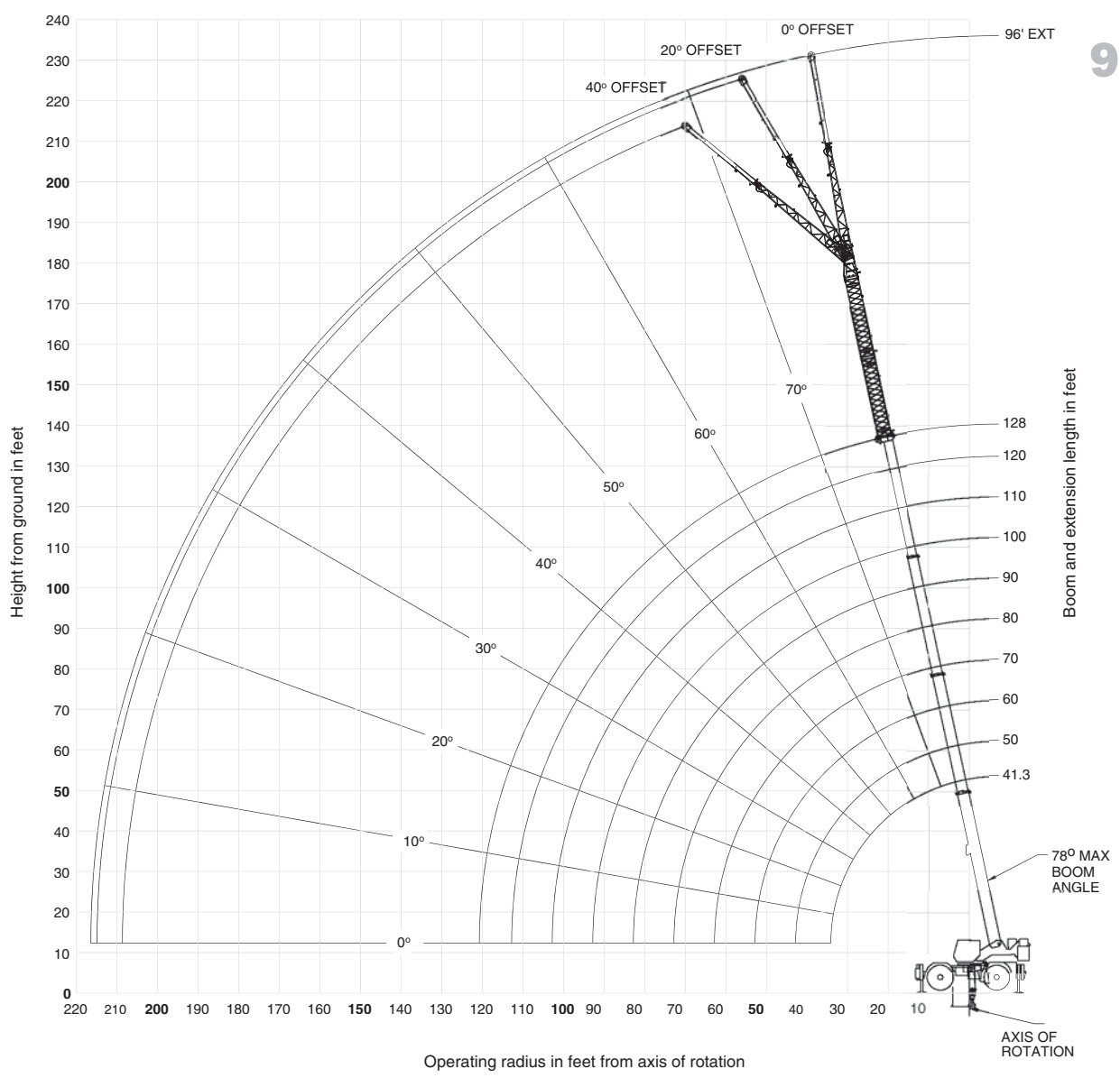

9

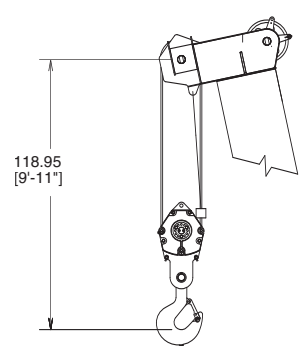

Dimensions are for largest Grove furnished hookblock and overhaul ball, with anti-two block activated.

THIS CHART IS ONLY A GUIDE AND SHOULD NOT BE USED TO OPERATE THE CRANE. The individual crane's load chart, operating instructions and other instructional plates must be read and understood prior to operating the crane.

RT875E

GROVE

RT875E load chart

10



Feet	Pounds					
	76 ft. (56 ft. LENGTH + 1 INSERT)			96 ft. (56 ft. LENGTH + 2 INSERTS)		
	0°	20°	40°	0°	20°	40°
	OFFSET	OFFSET	OFFSET	OFFSET	OFFSET	OFFSET
	#0084	#0085	#0086	#0084	#0085	#0086
50	4,850 (78)					
55	4,850 (77.5)			3,520 (78)		
60	4,850 (76)			3,520 (77.5)		
65	4,850 (74.5)	5,290 (78)		3,520 (76.5)		
70	4,850 (73)	4,860 (77.5)		3,520 (75)		
75	4,850 (71.5)	4,470 (76)		3,520 (73.5)	3,740 (78)	
80	4,730 (70)	4,110 (74.5)	4,050 (78)	3,520 (72.5)	3,420 (76.5)	
85	4,310 (68.5)	3,790 (73)	3,500 (76.5)	3,300 (71)	3,100 (75)	3,250 (78)
90	3,940 (67)	3,500 (71)	3,260 (75)	2,970 (69.5)	2,820 (73.5)	2,720 (77)
95	3,610 (65.5)	3,240 (69.5)	3,030 (73)	2,660 (68)	2,560 (72)	2,490 (75.5)
100	3,310 (64)	3,000 (68)	2,830 (71.5)	2,390 (66.5)	2,320 (71)	2,270 (74)
105	3,040 (62)	2,770 (66)	2,630 (69.5)	2,140 (65)	2,100 (69.5)	2,070 (72)
110	2,790 (60.5)	2,570 (64.5)	2,450 (68)	1,920 (63.5)	1,900 (68)	1,890 (70.5)
115	2,560 (58.5)	2,370 (62.5)	2,280 (66)	1,710 (62)	1,710 (66.5)	1,710 (69)
120	2,350 (57)	2,200 (61)	2,120 (64)	1,520 (60.5)	1,540 (64.5)	1,550 (67.5)
125	2,160 (45)	2,030 (49)	1,970 (51.5)	1,350 (62)	1,380 (63)	1,390 (66)
130	1,990 (53)	1,880 (57)	1,830 (60)	1,190 (57.5)	1,230 (61.5)	1,250 (64)
135	1,820 (51.5)	1,730 (55)	1,700 (58)	1,040 (56)	1,080 (60)	1,110 (62.5)
140	1,670 (49.5)	1,590 (53)	1,570 (56)			
145	1,530 (47)	1,470 (51)	1,450 (53.5)			
150	1,400 (45)	1,340 (49)	1,340 (51.5)			
155	1,270 (43)	1,230 (46.5)	1,230 (48.5)			
160	1,160 (40.5)	1,120 (44)	1,130 (46)			
165	1,050 (38)	1,020 (41.5)				
Minimum boom angle (°) for indicated length (no load)	36	40	44	54	58	60
Maximum boom length (ft.) at 0° boom angle (no load)		70		60		

NOTE: () Boom angles are in degrees. #LMI operating code. Refer to LMI manual for operating instructions. *This capacity is based upon maximum boom angle. RT875E - S/N 229983 A6-829-103655

NOTES:

- All capacities above the bold line are based on structural strength of boom extension and do not exceed 85% of tipping loads, in accordance with SAE J-765.
- The 56 ft. boom extension length may be used for single line lifting service only.
- For main boom lengths less than 128 ft. with the boom extension erected, the rated loads are determined by boom angle. Use only the column which corresponds to the boom extension length and offset for which the machine is set up. For boom angles not shown, use rating of the next lower boom angle.
- WARNING:** Operation of this machine with heavier loads than the capacities listed is strictly prohibited. Machine tipping with boom extension occurs rapidly and without advance warning.
- Boom angle is the angle above or below horizontal of the longitudinal axis of the boom base section after lifting rated load.
- When lifting over the main boom nose with 56 ft. extension erected and inserts, the outriggers must be fully extended and vertical jacks set.

RT875E



Feet	Pounds					
	#9005					
	Main Boom Length in Feet					
	41.3	50	60	*70	80	90
12	49,200 (67.5)	40,750 (72)				
15	38,150 (63)	35,700 (68.5)				
20	24,200 (54.5)	24,350 (62)	22,800 (67.5)	22,000 (71)		
25	16,200 (44.5)	16,200 (55)	15,600 (62)	15,950 (66.5)	15,850 (70)	
30	11,250 (31.5)	11,250 (47)	10,950 (56)	10,650 (62)	11,600 (66)	12,150 (69.5)
35		7,900 (37.5)	7,690 (49.5)	7,270 (57)	8,420 (62)	8,820 (65)
40		5,490 (24.5)	5,280 (42.5)	4,880 (52)	6,020 (58)	6,330 (62)
45			3,430 (34)	3,110 (46)	4,130 (53)	4,480 (58.5)
50			1,350 (22)	1,740 (39.5)	2,610 (48.5)	3,040 (54.5)
55					1,360 (43)	1,070 (50)
Minimum boom angle (deg.) for indicated length (no load)		21	38.5		42	49
Maximum boom length (ft.) at 0 deg. boom angle (no load)				50		

#LMI operating code. Refer to LMI manual for instructions.
 Note: () Boom angles are in degrees.
 *This boom length is with inner-mid fully extended and outer-mid & fly fully retracted.

Boom Angle	Lifting Capacities at Zero Degree Boom Angle	
	Main Boom Length in Feet	
0°	41.3 (34.1)	50 (42.8)

Note: () Reference radii in feet. A6-829-0103649A



Feet	Pounds					
	#9006					
	Main Boom Length in Feet					
	41.3	50	60	*70	80	90
12	59,450 (67.5)	49,400 (72)				
15	49,650 (63)	49,400 (68.5)				
20	38,100 (54.5)	37,800 (62)	36,850 (67.5)	29,750 (71)		
25	30,000 (44.5)	29,700 (55)	29,200 (62)	29,700 (66.5)		
30	24,100 (31.5)	23,750 (47)	23,500 (56)	23,850 (62)	24,450 (66)	
35		18,000 (37.5)	17,900 (49.5)	18,150 (57)	19,000 (62)	19,900 (66)
40		13,650 (24.5)	13,700 (42.5)	13,750 (52)	14,700 (58)	15,500 (62)
45			9,400 (34)	9,290 (46)	11,500 (53)	12,300 (58.5)
50			7,420 (22)	7,200 (39.5)	8,220 (48.5)	8,980 (54.5)
55				5,450 (31.5)	6,510 (43)	7,220 (50)
60				3,970 (21)	5,060 (37)	5,740 (45.5)
65					3,810 (29.5)	4,460 (40.5)
70					2,720 (19)	3,350 (34.5)
75						2,380 (28)
80						1,520 (18)
Minimum boom angle (deg.) for indicated length (no load)						0
Maximum boom length (ft.) at 0 deg. boom angle (no load)						90

#LMI operating code. Refer to LMI manual for instructions.
 Note: () Boom angles are in degrees.

Boom Angle	Lifting Capacities at Zero Degree Boom Angle					
	Main Boom Length in Feet					
0°	41.3 (34.1)	50 (42.8)	60 (52.8)	70 (63)	80 (72.6)	90 (82.8)

Note: () Reference radii in feet. *This boom length is with inner-mid fully extended and outer-mid & fly fully retracted. A6-829-0103650

NOTES:

- Capacities are in pounds and do not exceed 75% of tipping loads as determined by test in accordance with SAE J765.
- Capacities are applicable to machines equipped with 29.6x25 (34 ply) General tires at 76 psi cold inflation pressure.
- Capacities appearing above the bold line are based on structural strength and tipping should not be relied upon as a capacity limitation.
- Capacities are applicable only with machine on firm level surface.
- On rubber lifting with boom extensions not permitted.
- For pick and carry operation, boom must be centered over front of machine, mechanical swing lock engaged and load restrained from swinging. When handling loads in the structural range with capacities close to maximum ratings, travel should be reduced to creep speeds.
- Axle lockouts must be functioning when lifting on rubber.
- All lifting depends on proper tire inflation, capacity and condition. Capacities must be reduced for lower tire inflation pressures. See lifting capacity chart for tire used. Damaged tires are hazardous to safe operation of crane.
- Creep - Not over 200 ft. of movement in any 30 minute period and not exceeding 1 mph.

THIS CHART IS ONLY A GUIDE AND SHOULD NOT BE USED TO OPERATE THE CRANE. The individual crane's load chart, operating instructions and other instructional plates must be read and understood prior to operating the crane.



load handling

11

Weight Reductions for Load Handling Devices

33 FT.-56 FT. FOLDING BOOM EXTENSION	
*33 ft. Extension (Erected) -	3,700 lb.
*56 ft. Extension (Erected) -	7,830 lb.
*76 ft. (1 insert Erected) -	10,350 lb.
*96 ft. (2 inserts Erected) -	13,300 lb.
*Reduction of main boom capacities (no deduct required for stowed boom extension)	

When lifting over swingaway and/or jib combinations, deduct total weight of all load handling devices reeved over main boom nose directly from swingaway or jib capacity.

NOTE: All load handling devices and boom attachments are considered part of the load and suitable allowances **MUST BE MADE** for their combined weights. Weights are for Grove furnished equipment.

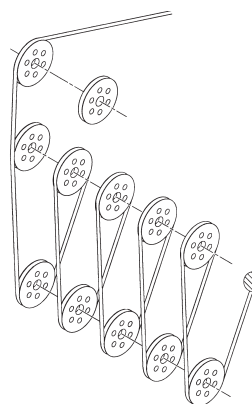

Line Pulls and Reeving Information

Hoists	Cable Specs	Permissible Line Pulls	Nominal Cable Length
Main	3/4" (19 mm) 6x37 Class, EIPS, IWRC Special Flexible Min. Breaking Str. 58,800 lb.	16,800 lb.	600 ft.
Main & Aux.	3/4" (19 mm) Flex-X 35 Rotation Resistant (non-rotating) Min. Breaking Strength 85,800 lb.	16,800 lb.	607 ft.
The approximate weight of 3/4" wire rope is 1.5 lb./ft.			

Hoist Performance

Wire Rope Layer	Hoist Line Pulls Two Speed Hoist		Drum Rope Capacity (ft.) 15 in. Drum	
	Low Available lb.*	High Available lb.*	Layer	Total
1	20,250	9,610	101	101
2	18,490	8,770	110	211
3	17,010	8,070	120	331
4	15,750	7,470	129	460
5	14,660	6,960	139	599

*Max. lifting capacity: 6x37 or 35x7 class = 16,800 lb.

Line Pulls and Reeving Information

AUXILIARY BOOM NOSE	136 lb.
HOOKBLOCK AND OVERHAUL BALL:	
75 Ton, 4 Sheave	1,275 lb.+
10 Ton, Overhaul Ball	568 lb. +
+Refer to rating plate for actual weight.	

Installation and Removal of Counterweight and Auxiliary Hoist

Rated Lifting Capacities in Pounds on Outriggers Fully Extended - 360°

Radius in Feet	LMI Code #0801 Main Boom Length
10	41.3 ft.*
12	24,000
15	24,000
20	24,000
25	24,000
30	24,000

*The boom must be fully retracted.

Boom Section vs. Section Extension Percentages

Boom sections:	Main Boom Length in Feet									
	41.3	50	60	70	80	90	100	110	120	128
Inner-mid	0	30	65	100	100	100	100	100	100	100
Outer-mid	0	0	0	0	17	34	52	69	86	100
Fly	0	0	0	0	17	34	52	69	86	100

Working Area Diagram

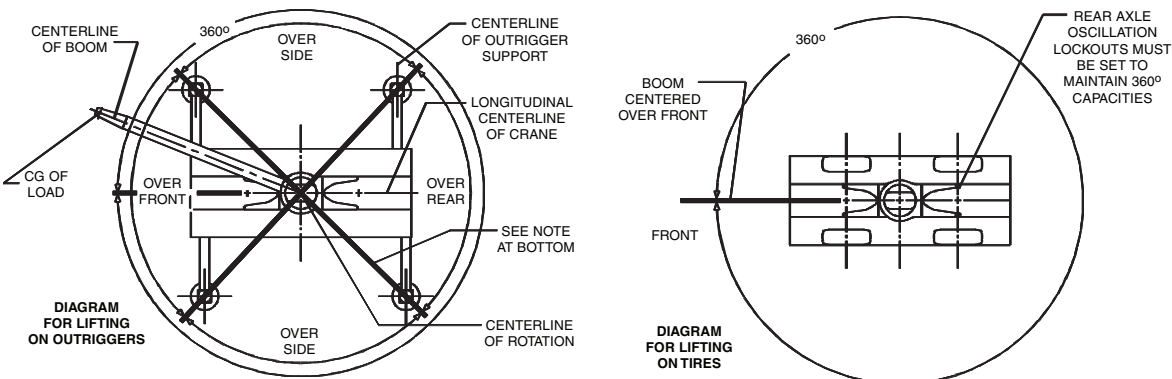

Bold lines determine the limiting position of any load for operation within working areas indicated.

THIS CHART IS ONLY A GUIDE AND SHOULD NOT BE USED TO OPERATE THE CRANE. The individual crane's load chart, operating instructions and other instructional plates must be read and understood prior to operating the crane.

RT875E

GROVE





Manitowoc Crane Group - Americas

Manitowoc, Wisconsin Facility
Tel: [Int + 001] 920 684 6621
Fax: [Int + 001] 920 683 6277
Shady Grove, Pennsylvania Facility
Tel: [Int + 001] 717 597 8121
Fax: [Int + 001] 717 597 4062

Manitowoc Crane Group - EMEA

Europe Middle East & Africa
Tel: [Int + 33] (0) 472 18 20 20
Fax: [Int + 33] (0) 472 18 20 00

Manitowoc Crane Group - UK

Europe Middle East & Africa
Tel: [Int + 44] (0) 191 565 6281
Fax: [Int + 44] (0) 191 564 0442

Manitowoc Crane Group - Germany

(Sales, Parts & Service)
Tel: [Int + 49](0) 2173 8909 0
Fax: [Int + 49] (0) 2173 8909-30

Manitowoc Crane Group - France

France & Africa (Sales, Parts & Service)
Tel: [Int + 33] (0) 1 303 13150
Fax: [Int + 33] (0) 1 303 86085

Manitowoc Crane Group - Netherlands

(Sales, Parts & Service)
Tel: [Int + 31] (0) 76 578 39 99
Fax: [Int + 31] (0) 76 578 39 78

Manitowoc Crane Group - Italy

Italy & Southern Europe (Sales, Parts & Service)
Tel: [Int + 39] (0) 331 49 33 11
Fax: [Int + 39] (0) 331 49 33 30

Manitowoc Crane Group - Portugal

Portugal & Spain (Sales, Parts & Service)
Tel: [Int + 351] (0) 22 968 08 89
Fax: [Int + 351] (0) 22 968 08 97

Manitowoc Crane Group - Singapore

Asia/Pacific excl China (Sales, Parts & Service)
Tel: [Int + 65] 6861 1733
Fax: [Int + 65] 6862 4040 / 4142

Manitowoc Crane Group - Shanghai

China (Sales, Parts & Service)
Tel: [Int + 86] (0) 21 64955555
Fax: [Int + 86] (0) 2164852038

Manitowoc Crane Group - Beijing

China (Sales, Parts & Service)
Tel: [Int + 86] (0) 10 646 71690
Fax: [Int + 86] (0) 10 646 71691

Manitowoc Crane Group - Middle East

(Sales)
Tel: [Int + 971] (0) 4 348 4478
Fax: [Int + 971] (0) 4 348 4478
(Parts & Service)
Tel: [Int + 973] (0) 9 660 899
Fax: [Int + 973] (0) 2 707 740

Distributed By:



Bigge Crane and Rigging Co.

10700 Bigge Avenue
San Leandro, CA 94577
Phone: (888) 337-BIGGE or (510) 638-8100
Fax: (510) 639-4053
Email: info@bigge.com
Web site: www.bigge.com



www.manitowoccrane.com

Constant improvement and engineering progress make it necessary that we reserve the right to make specification, equipment, and price changes without notice. Illustrations shown may include optional equipment and accessories, and may not include all standard equipment.