

Technical Data

Specifications & Capacities

RTC-8060

Telescopic Boom Rough Terrain Crane
60 ton (54.4 metric ton)

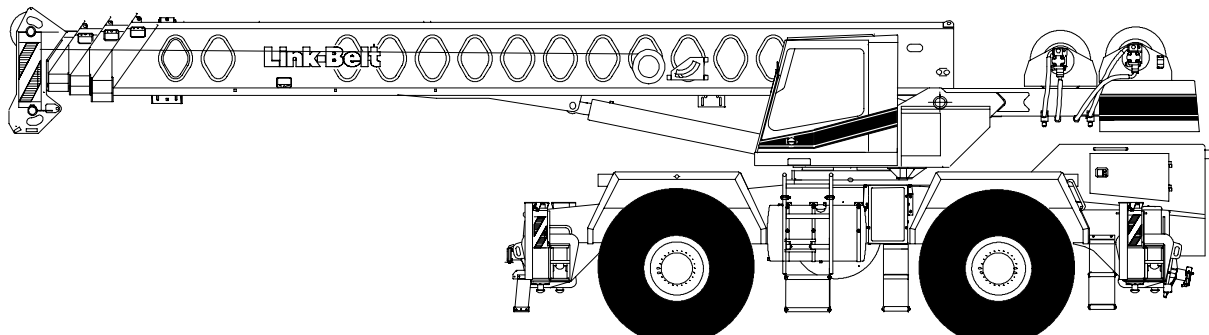

CAUTION: This material is supplied for reference use only. Operator must refer to in-cab Crane Rating Manual and Operator's Manual to determine allowable crane lifting capacities and assembly and operating procedures.



5447-0205-E1

Table Of Contents

	Pages
Specifications	1-4
Capacities	1-12



This page intentionally left blank



Specifications

Telescopic Boom Rough Terrain Crane

RTC-8060

60-ton (54.43 metric tons)

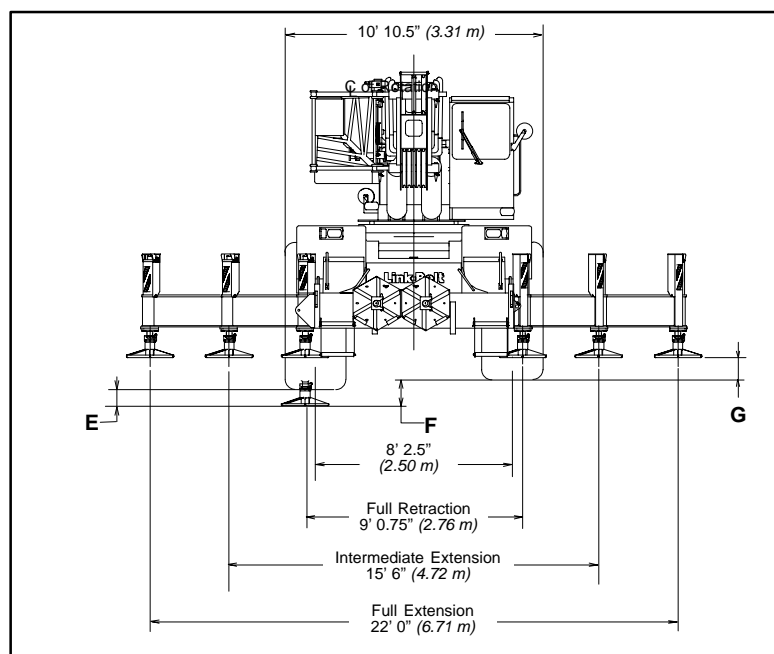
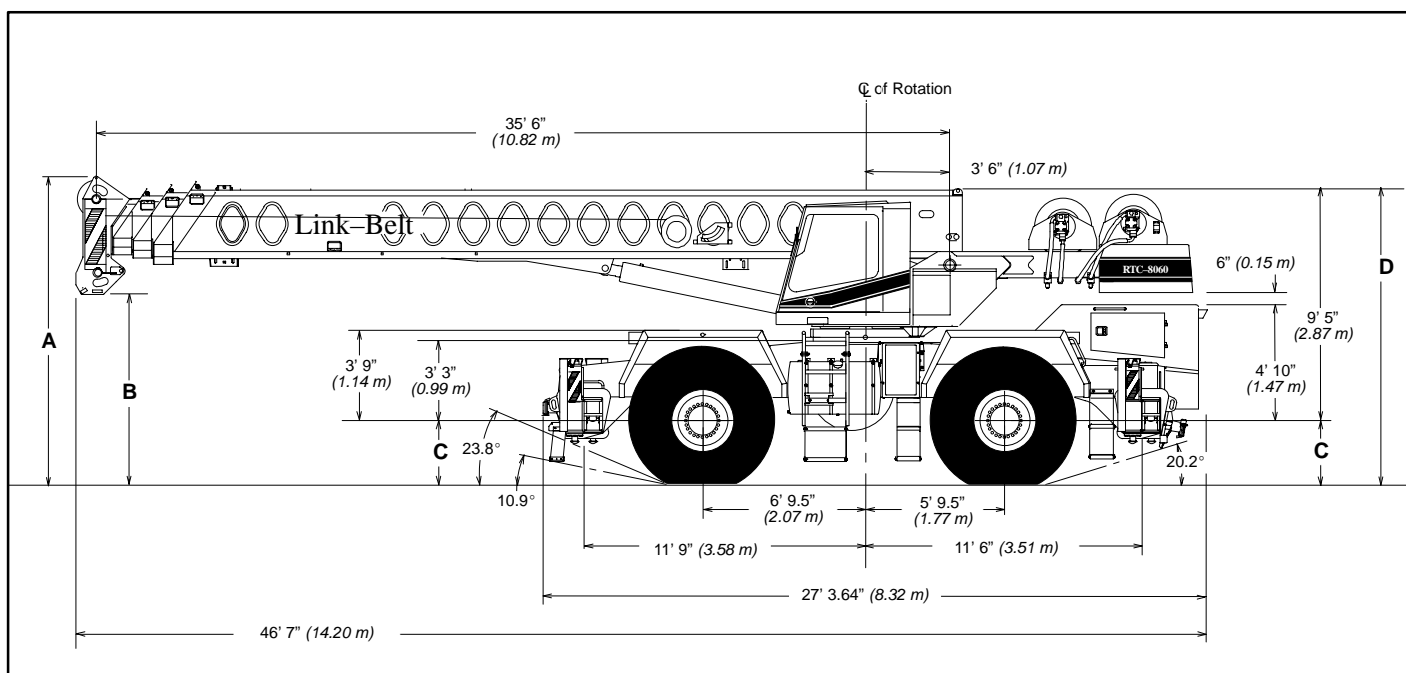

General Dimensions		feet	meters
Turning radius (4-wheel steer centerline of tires)		23' 10"	7.26
Turning radius (2-wheel steer centerline of tires)		46' 10"	14.27
Turning radius (4-wheel steer outside front carrier corner)		27' 5"	8.36
Turning radius (2-wheel steer outside front carrier corner)		49' 10"	15.19
Dimension	Tire Size		
	29.5 x 25	29.5 R 25	
A	12' 10.25" (3.92 m)	12' 11.25" (3.94 m)	
B	7' 11" (2.39 m)	8' 0" (2.42 m)	
C	2' 8" (0.81 m)	2' 9" (0.84 m)	
D	12' 4.25" (3.77 m)	12' 5.25" (3.79 m)	
E	9" (0.23 m)	10" (0.25 m)	
F	14.25" (0.36 m)	15.25" (0.39 m)	
G	11.25" (0.29 m)	12.25" (0.31 m)	



Link-Belt

CONSTRUCTION EQUIPMENT

Upper Structure

■ Boom

Patented Design

- Boom side plates have diamond shaped impressions for superior strength to weight ratio and 100,000 p.s.i. (689.5 MPa) steel angle chords for lateral stiffness.
- Boom telescope sections are supported by top, bottom and adjustable side wear shoes to prevent metal to metal contact.

Standard Boom

- 35.5' – 110' (10.82 – 33.53 m) four-section full power boom.
- Basic mode (or mode 'B') is the full power, synchronized mode of telescoping all sections proportionally 110' (33.53 m).
- The exclusive **A-max** mode (or mode 'A') extends only the inner mid-section to 60.3' (18.38 m) offering increased capacities for in-close, maximum capacity picks.
- Mechanical Boom Angle Indicator

Boom Head

- Five 16.5" (0.42 m) root diameter nylon sheaves handle up to ten parts of wire rope.
- Quick reeve design
- Boom head designed for quick reeve of hook block.
- Rope dead end lugs provided on each side of boom head.
- Easily removable wire rope guards
- Fly pinning alignment tool

Boom Elevation

- Two hydraulic cylinders with holding valves and bushings in each end.
- Foot control for controlling boom elevation from -3° to +78°.
- Hand and foot control for controlling boom elevation – optional.

Optional Auxiliary Lifting Sheave

- Single 16.5" (0.42 m) root diameter nylon sheave with removable wire rope guard mounted on boom.
- Use with one or two parts of line.
- Does not affect erection of fly or use of main head sheaves for multiple reeving.

Optional

- 70-ton (63.50 mt) 5-sheave, quick reeve hook block
- 60-ton (54.43 mt) 4-sheave, quick reeve hook block
- 40-ton (36.29 mt) 4-sheave, quick reeve hook block
- 8.5-ton (7.7 mt) hook ball
- Boom floodlight

■ Fly

Optional

- 34' (10.36 m) One piece lattice fly, stowable, offsettable to 1°, 15° or 30° with or without additional lugs to allow for second section.
- 34' – 56' (10.36 – 17.07 m) Two piece (bi-fold) lattice fly, stowable, offsettable to 1°, 15° or 30°.

■ Cab and Controls

Environmental Cab

- Isolated from sound and vibration by a neoprene seal.
- Six-way adjustable operator's seat with retractable seat belt.
- Four-way adjustable tilting-telescoping and locking steering wheel.
- All windows are tinted and tempered safety glass.
- Slide by door opens to 3' (0.91 m) width.
- Sliding rear and right side windows and swing up roof windows for maximum visibility and ventilation.
- Engine dependent warm-water heater with defroster.
- Dash mounted outrigger controls
- Sight level bubble
- Audible swing alarm
- Backup alarm
- Sun screen
- Electric windshield wiper
- Windshield washer
- Fire extinguisher
- Top hatch window wiper
- Hand throttle
- Warning horn
- Travel lights
- Circulating fan
- Mirrors
- Cup holder

Optional

- Amber strobe light and rotating beacon
- Emergency steering system
- Rear steer indicator
- Air conditioning
- Cab mounted spotlight

Controls

Hydraulic control levers for:

- Main winch
- Boom hoist
- Boom telescope
- Swing
- Drum rotation Indicators
- Optional – auxiliary winch controls

Foot controls for:

- Swing brake
- Foot throttle
- Boom hoist foot control – optional

Cab Instrumentation

Dash mounted gauges for:

- Hydraulic oil temperature
- Fuel
- Converter temperature
- Voltmeter
- Oil pressure
- Tachometer
- Audio / visual warning system
- Water temperature

■ Rated Capacity Limiter

- **Microguard 434** Graphic audio-visual warning system built into dash with anti-two block and function limiters.

Operating data available includes:

- Machine configuration
- Boom length
- Head height
- Allowed load
- % of allowed load
- Boom angle
- Radius of load
- Actual load

Presetable alarms include:

- Maximum and minimum boom angles
- Maximum tip height
- Maximum boom length
- Swing left/right positions.
- Operator defined area alarm is standard.
- Anti-two block weight designed for quick reeve of hookblock.

Optional

- **Internal RCL light bar:** Visually informs operator when crane is approaching maximum load capacity with a series of lights; green, yellow and red.
- **External RCL light bar:** Visually informs ground crew when crane is approaching maximum load capacity kickouts and pre-settable alarms with a series of three lights; green, yellow and red.

■ Swing

- Bi-directional hydraulic swing motor mounted to a planetary reducer for 360° continuous smooth swing at 2.4 r.p.m.
- **Swing brake** – 360°, foot operated, hydraulic applied disc brake mounted on the speed reducer.
- **Counterweight** – Pinned to the upper structure of frame. 12,900 lbs. (5 851 kg).
- **360° Swing Lock** – meets New York City requirements.

■ Hydraulic System

Main Pump

- Three-section gear-type pump
- Combined pump capacity 136 gpm (515 lpm)
- Mounted on torque converter, powered by engine through a pump disconnect.
- Pump disconnect is a spline-type clutch engaged/disengaged from carrier.
- Pump operates at 3,000 p.s.i. (20.7 MPa) maximum system pressure.

Brake Pump

- Pressure compensated piston pump powered by carrier engine. Operates at 2,650 psi (18.3 Mpa) maximum.

Swing / Outrigger / Steering Pump

- Single gear-type pump, 24 gpm (91 lpm) maximum. Mounted on torque converter, powered by engine through a straight mechanical drive.
- Pump operates at 3,000 p.s.i. (20.7 MPa) maximum system pressure.

Reservoir

- 170 gal. (643.5 l) capacity. Diffusers for deaeration

Filtration

- One, 10-micron filter located inside hydraulic reservoir. Accessible for easy replacement.



Control Valves:

- Six separate pilot operated control valves allow simultaneous operation of all crane functions.

Load Hoist System

Standard

- 2M rear winch with grooved lagging.

- Two-speed motor and automatic brake.
- Power up/down mode of operation.
- Controls for future addition of auxiliary winch.
- Bi-directional gear-type hydraulic motor, driven through a planetary reduction unit for positive operator control under all load conditions.
- Asynchronous parallel double crossover grooved drums minimize rope harmonic motion.

Line Pulls and Speeds

- Maximum line pull 16,266 lbs. (7 378 kg) and maximum line speed of 454 f.p.m. (138 m/min) on standard 16" (0.41 m) root diameter grooved drum
- Rotation resistant rope

Optional

- 2M front winch with two-speed motor and automatic brake, power up/down mode of operation.

Carrier

Type

- 10' 10.5" (3.31 m) wide, 151" (3.84 m) wheelbase.
- 4 x 4 x 4 – (4-wheel steer, 4-wheel drive) For rough terrain with limited turning area.

Frame

- 100,000 p.s.i. (689.5 MPa) steel, double walled construction.
- Integral 100,000 p.s.i. (689.5 MPa) steel outrigger boxes.

Standard Carrier Equipment

- Two front and rear carrier steps
- Non-slip safety strips on carrier deck
- Deep front storage
- Fenders
- Pontoon storage
- Full lighting package
- Lifting lugs
- Front towing shackles

Optional

- Front and rear mounted pintle hook
- Front tow winch

Engine

Engine	Caterpillar 3126B 7.2L
Cylinders – cycle	6 – 4
Bore	4.33 in. (110 mm)
Stroke	5.00 in. (127 mm)
Displacement	442 cu. in. (7.2 L)
Maximum brake hp	225 @ 2,200 rpm
Peak torque (ft. lb.)	646 @ 1,500 rpm
Electric system	12 volt
Starting system	12 volt
Fuel capacity	95 gallons (359.61 l)
Alternator	130 amps
Crankcase capacity (total system)	30 qts. (28 l)

- Water/fuel separator on engine
- Ether injection package – optional

Transmission

- Spicer off-highway three-speed, two range power shift transmission.
- Six speeds forward and two reverse
- Front axle disconnect for two or four-wheel drive.

Axles

- Front and Rear – Heavy duty planetary drive/steer type.
- Front axle disconnect

Suspension

Front Axle

- Rigid mounted to frame.

Rear Axle

- Pin mounted on bronze bushings.
- Automatic hydraulic rear axle oscillation lock-out cylinders engage when upper structure rotates past 2.5° of centerline.

Steering

- Hydraulic two-wheel, four-wheel and "crab" steering.
- Modes selected by toggle switch on dash.
- All modes fully controlled by steering wheel.

Tires

Front and Rear

- Standard 29.5 x 25 (28-PR) Earthmover type

Optional

- 29.5R25 XHA 1 star radials
- Spare tires and rims.

Brakes

Service

- Hydraulic disc-type brakes at each wheel end.

Parking/Emergency

- Disc-type spring applied, hydraulic release, cab controlled, mounted to front axle.

Outriggers

- Three position operation capability.
- Four hydraulic, telescoping beam and jack outriggers.
- Vertical jack cylinders equipped with integral holding valve.
- Beams extend to 22' 0" (6.71 m) centerline-to-centerline and retract to within 10' 10.5" (3.31 m) overall width.
- Equipped with stowable, lightweight 23.5" x 27.25" (59.7 x 69.2 cm) hexagonal steel pontoons.
- Controls and sight level bubble located in upper structure cab.

Confined Area Lifting Capacities (CALC™) System

- Three operational outrigger configurations are available:
 - Full extension –24' 0" (7.32 m)
 - Intermediate position – 17' 6" (5.33 m).
 - Full retraction –11' 0.75" (3.37 m).
- For confined area operation, rated lifting capacities are provided for the intermediate and fully retracted outrigger positions.
- When the outrigger position levers (located on the outrigger beams) are engaged, the operator can set the crane in the intermediate or full retraction outrigger position without having to leave the cab.

Optional

- Outrigger cover package

Travel Speeds and Gradability

Tires	29.5 x 25
Maximum Speed	19.8 (31.9 km/h)
Gradability at 70% convertor efficiency	140.7%
Maximum Tractive Effort at 70% convertor efficiency	76,507 lbs. (34 703 kg)
Gradability at 1.0 mph (1.6 km/hr)	62.5%
Maximum Tractive Effort at 1.0 mph. (1.61 km/hr)	50,376 lbs. (22 850 kg)
Machine operating angle must not exceed 35° (77% grade). Numbers reflect main hydraulic pump engaged.	



Link-Belt

CONSTRUCTION EQUIPMENT

■ Axle Loads

Base machine with standard 35.5' – 110' (10.82 – 33.53 m) four-section boom, 2M main winch with 2-speed hoisting and power up/down, 600' (182.88 m) 3/4" (19 mm) wire rope. 4x4x4 carrier with Caterpillar 3126B 7.2L engine, 29.5 x 25 tires, counterweight and no fuel.	G.V.W. ¹		Upper facing front				Upper facing rear			
			Front axle		Rear axle		Front axle		Rear axle	
	lbs.	kg.	lbs.	kg.	lbs.	kg.	lbs.	kg.	lbs.	kg.
	83,482	37 867	41,285	18 727	42,197	19 140	35,563	16 131	47,919	21 736
29.5R25 XHA Tires	1,240	562	620	281	620	281	620	281	620	281
Jack cylinder beams	154	70	72	33	82	37	72	33	82	37
Tow winch	686	311	1,002	454	-316	-143	1,002	454	-316	-143
100 gallons (378.5 l) fuel	685	310	364	165	321	145	364	165	321	145
2M auxiliary winch with 600' (182.88 m) of 3/4" (19 mm) rope	908	412	142	64	766	348	695	315	212	97
Air conditioning	264	120	69	31	195	89	174	79	90	41
34' (10.36 m) One-piece lattice fly, stowable	1,383	627	2,778	1 260	-1,395	-633	-1,505	-683	2,888	1 310
34' (10.36 m) One-piece lattice fly, with tip lugs, stowable	1,466	665	2,945	1 336	-1,479	-671	-1,595	-723	3,061	1 388
34' – 56' (10.36 – 17.07 m) Two-piece (bifold) lattice fly, stowable	2,122	963	3,913	1 775	-1,791	-812	-1,959	-888	4,081	1 851
Fly storage brackets with all fly options	160	73	257	117	-97	-44	-110	-49	270	122
Auxiliary lifting sheave assembly	110	50	343	156	-233	-106	-242	-109	352	159
8.5-ton (7.71 mt) hook ball @ front bumper	325	147	977	443	-652	-296	-677	-307	1,002	454
40-ton (36.45 mt) 4-sheave hook block @ front bumper	720	327	2,164	982	-1,444	-655	-1,501	-681	2,221	1 007
60-ton (54.43 mt) 4-sheave hook block @ front bumper	1,109	503	3,333	1 512	-2,224	-1 009	-2,312	-1 049	3,421	1 552
70-ton (63.50 mt) 5-sheave hook block @ front bumper	1,390	631	2,186	992	-796	-361	n/a	n/a	n/a	n/a

¹ – Adjust gross weight and axle loading according to component weight. Note: All weights are ± 3%.

Tire	Max. Axle Load @ 20 mph (32.2 km/hr)
29.5 x 25 (28-PR)	53,000 (24 040 kg)
29.5R25 XHA 1 Star	53,000 (24 040 kg)

Link-Belt Construction Equipment Company Lexington, Kentucky www.linkbelt.com

©Link-Belt is a registered trademark. Copyright 2005. All rights reserved. We are constantly improving our products and therefore reserve the right to change designs and specifications.



Lifting Capacities

Telescopic Boom Rough Terrain Crane

RTC-8060 60-ton (54.43 metric ton)

Boom and fly capacities for this machine are listed by the following sections:

Fully Extended Outriggers

- Working Range Diagram (12,900 lbs. Counterweight)
- 35.5' – 60.3' (10.82 – 18.38 m) Main Boom Capacities, **A-max** Mode
- 35.5' – 110' (10.82 – 33.53 m) Main Boom Capacities, Basic Mode "B"
- 34' (10.36 m) Offset Fly Capacities, Basic Mode "B"
- 34' – 56' (10.36 – 17.07 m) Two-piece Offset Fly Capacities, Basic Mode "B"

On Tires

- Working Range Diagram (12,900 lbs. Counterweight)
- 35.5' – 60.3' (10.82 – 18.38 m) Main Boom Capacities, **A-max** Mode
- 35.5' – 110' (10.82 – 33.53 m) Main Boom Capacities, Basic Mode "B"

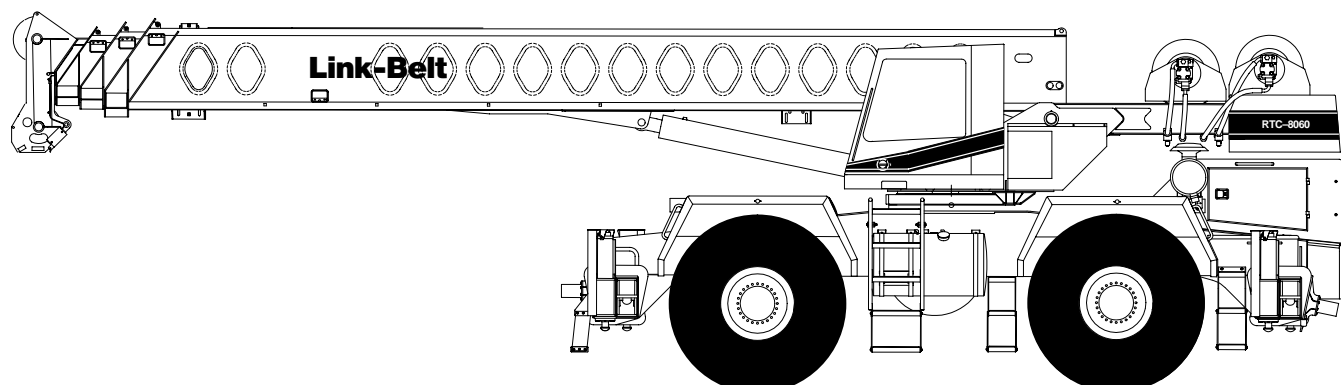

CAUTION: This material is supplied for reference use only. Operator must refer to in-cab Crane Rating Manual to determine allowable machine lifting capacities and operating procedures.



WARNING

READ AND UNDERSTAND THE OPERATOR'S AND SAFETY MANUALS AND THE FOLLOWING INSTRUCTIONS AND RATED LIFTING CAPACITIES BEFORE OPERATING THE CRANE. OPERATION WHICH DOES NOT FOLLOW THESE INSTRUCTIONS MAY RESULT IN AN ACCIDENT.

OPERATING INSTRUCTIONS

GENERAL:

1. Rated lifting capacities in pounds as shown on lift charts pertain to this crane as originally manufactured and normally equipped. Modifications to the crane or use of optional equipment other than that specified can result in a reduction of capacity.
2. Construction equipment can be dangerous if improperly operated or maintained. Operation and maintenance of this crane must be in compliance with the information in the Operator's, Parts, and Safety Manuals supplied with this crane. If these manuals are missing, order replacements through the distributor.
3. The operator and other personnel associated with this crane shall read and fully understand the latest applicable American National Standards Institute (ANSI) safety standards for cranes.
4. The maximum allowable lifting capacities are based on crane standing level on firm supporting surface.

SET UP:

1. The crane shall be leveled on a firm supporting surface. Depending on the nature of the supporting surface, it may be necessary to have structural supports under the outrigger pontoons or tires to spread the load to a larger bearing surface.
2. When making lifts on outriggers, all tires must be free of supporting surface. All outrigger beams must be extended to the same length; fully retracted, intermediate, or fully extended.
3. When making lifts on tires, they must be inflated to the recommended pressure. (See Operation note 19 and Tire Inflation.)
4. When operating on tires, do not exceed 76 degree maximum boom angle. Loss of backward stability will occur causing a tipping condition.
5. For required parts of line, see Wire Rope Capacity and Winch Performance.

OPERATION:

1. Rated lifting capacities at rated radius shall not be exceeded. Do not tip the crane to determine allowable loads. For concrete bucket operation, weight of bucket and load shall not exceed 80% of rated lifting capacities. For clamshell bucket operation, weight of bucket and bucket contents is restricted to a maximum weight of 7000 pounds or 80% of rated lifting capacity, whichever is less. For magnet operation, weight of magnet and load is restricted to a maximum weight of 7000 pounds or 80% of rated lifting capacity, whichever is less. For clamshell and magnet operation, maximum boom length is restricted to 55 feet and the boom angle is restricted to a minimum of 35 degrees. Lifts with either fly erected or boom in "Mode A" are prohibited for both clam and magnet operation.
2. The crane capacities shown on fully extended, or intermediate extended outriggers do not exceed 85% of the tipping loads. The crane capacities shown on fully retracted outriggers or tires do not exceed 75% of the tipping loads as determined by SAE crane stability test code J-765A.

3. The crane capacities in the shaded areas above the bold lines, are based on structural strength or hydraulic limitations. The crane capacities below the bold lines are based on stability ratings. Some capacities are limited by a maximum obtainable 78° boom angle.
4. Rated lifting capacities include the weight of hook block, slings, bucket, magnet, and auxiliary lifting devices. Their weights must be subtracted from the listed rated capacity to obtain the net load which can be lifted. Also, see Capacity Deductions For Auxiliary Load Handling Equipment.
5. Rated lifting capacities are based on freely suspended loads. No attempt shall be made to move a load horizontally on the ground in any direction.
6. Rated lifting capacities are for lift crane service only.
7. Do not operate at any radii or boom lengths (minimum or maximum) where capacities are not listed. At these positions, the crane can overturn without any load on the hook or cause boom failure.
8. The maximum loads which can be telescoped are not definable because of variation in loadings and crane maintenance, but it is permissible to attempt retraction and extension within the limits of the applicable load rating chart.
9. For main boom capacities when either boom length or radius or both are between values listed, proceed as follows:
 - a. For boom lengths not listed, use rating for next longer boom length or next shorter boom length, whichever is smaller.
 - b. For load radii not listed, use rating for next larger radius.
10. The user shall operate at reduced ratings to allow for adverse job conditions, such as: soft or uneven ground, out of level conditions, wind, side loads, pendulum action, jerking or sudden stopping of loads, hazardous conditions, experience of personnel, traveling with loads, electrical wires, etc. Side load on boom or fly is extremely dangerous.
11. When making lifts with auxiliary head machinery, the effective length of the boom increases by 2 feet.
12. Power sections of boom must be extended in accordance with boom mode "A" or "B". In boom mode "B" all power sections must be extended or retracted equally.
13. The least stable rated working area on outriggers is over the side.
14. Rated lifting capacities are based on correct reeving. Deduction must be made for excessive reeving. Any reeving over minimum required (see Wire Rope Capacity) is considered excessive and must be accounted for when making lifts. Use working range diagram to estimate the extra feet of rope then deduct 1 lb for each extra foot of wire rope before attempting to lift a load.
15. The loaded boom angle combined with the boom length give only an approximation of the operating radius. The boom angle, before loading, should be greater to account for deflection. For main boom capacities, the loaded boom angle is for reference only. For fly capacities, the load radius is for reference only.



BOOM EXTENSION

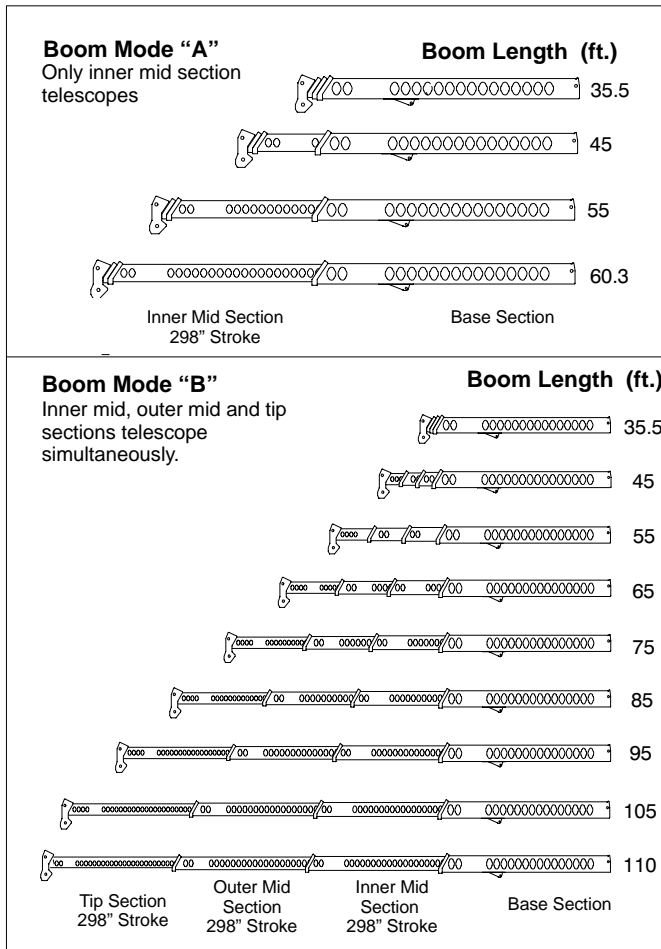

WINCH PERFORMANCE

Wire Rope Layer	Winch Line Pulls		Drum Rope Capacity (ft.)	
	Two Speed Winch		Layer	Total
	Low Speed Available lbs.	High Speed Available lbs.		
1	16,266*	7,726	102	102
2	14,998*	7,124	111	213
3	13,914*	6,609	120	333
4	12,976*	6,164	128	461
5	12,156	5,774	137	598
6	11,434	5,431	145	743

* - Reduce to 12,920 lbs. if using Type RB rope

WIRE ROPE CAPACITY

Maximum Lifting Capacities Based On Wire Rope Strength		
Parts of Line	3/4"	Notes
	Type RB	
1	12,920	Capacities shown are in pounds and working loads must not exceed the ratings on the capacity charts in the Crane Rating Manual. Study Operator's Manual for wire rope inspection procedures and single part of line applications.
2	25,840	
3	38,760	
4	51,680	
5	64,600	
6	77,520	
7	90,440	
8	103,360	
9	116,280	
10	129,200	

LBCE	DESCRIPTION
TYPE RB	18 X 19 Rotation Resistant – Compact Strand, High Strength Preformed, Right Regular Lay

HYDRAULIC CIRCUIT PRESSURE SETTINGS

Function	Pressure (PSI)
Front And Rear Winch	2,750
Outriggers	3,000
Boom Hoist	2,900
Telescope	3,000
Swing	1,500
Steering	2,500

TIRE INFLATION

Tire Size	Operation	Tire Pressure (psi)
29.5 X 25 – 28 PR	2.5 MPH	65
	Stationary	75

PONTOON LOADINGS

Maximum Pontoon Load:	Maximum Pontoon Ground Bearing Pressure:
94,000 lbs.	208 psi

CAPACITY DEDUCTIONS FOR AUXILIARY LOAD HANDLING EQUIPMENT

Load Handling Equipment:	(lbs.)
Auxiliary Head Attached	100
60-ton hook block (see hook block for actual weight)	1,100
40-ton hook block (see hook block for actual weight)	720
8.5-ton hook ball (see hook ball for actual weight)	360

Lifting From Main Boom With:	(lbs.)
22 ft. fly tip stowed on boom base	300
34 ft. offset fly stowed on boom base	900
34 ft. offset fly erected but not used	4,400
56 ft. offset fly stowed on boom base	1,200
56 ft. offset fly erected but not used	7,800

Lifting From 34 ft. Offset Fly With:	(lbs.)
22 ft. fly tip stowed on boom base	300
22 ft. fly tip erected but not used	PROHIBITED
22 ft. fly tip stowed on 34 ft. offset fly	PROHIBITED

Note: Capacity deductions are for Link-Belt supplied equipment only.

WORKING AREAS

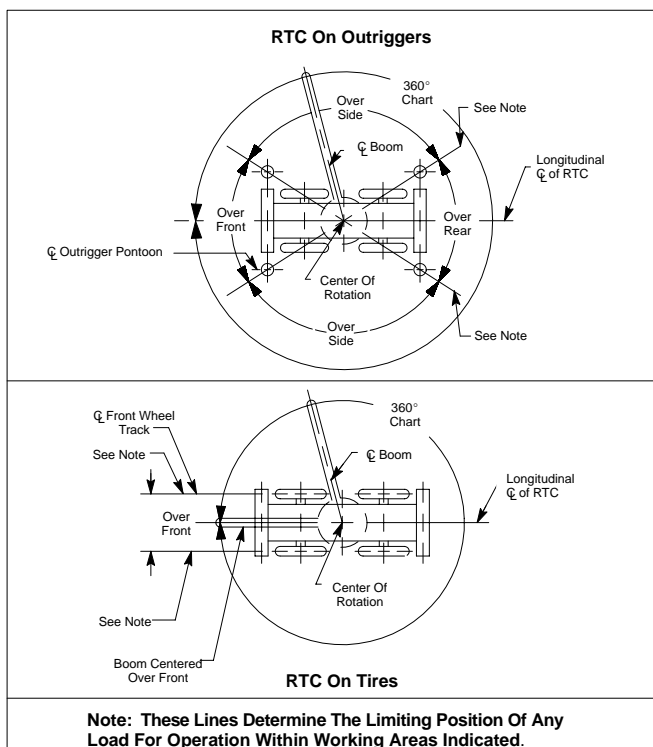

WORKING RANGE DIAGRAM

**Working Range Diagram
On Fully Extended Outriggers**

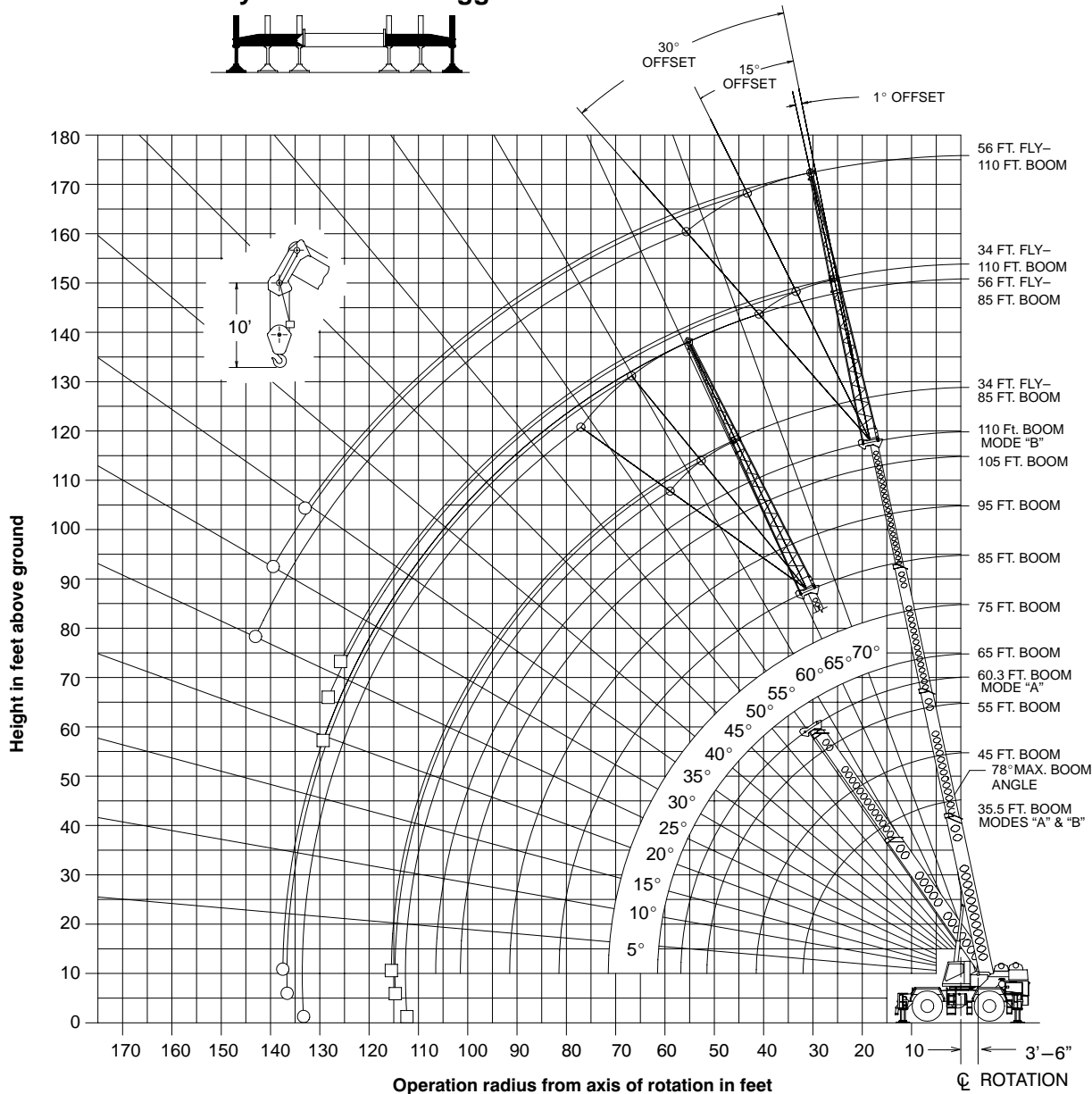

- Denotes Main Boom + 56' Fly-Boom Mode "B"
- Denotes Main Boom + 34' Fly-Boom Mode "B"

Note: Boom and fly geometry shown are for unloaded condition and crane standing level on firm supporting surface. Boom deflection, subsequent radius and boom angle change must be accounted for when applying load to hook.

WARNING

Do Not Lower The Boom Below The Minimum Boom Angle For No Load As Shown In The Above Chart For The Boom Lengths Shown. Loss Of Stability Will Occur Causing A Tipping Condition.

Note: Refer To Page 3 For “Lifting Capacity Deductions” For Capacity Reductions Caused By Stowed Or Erected Auxiliary Load Handling Equipment. * This Capacity Based On Maximum Obtainable Boom Angle.

Rated Lifting Capacities In Pounds On Fully Extended Outriggers. See Set Up Note 2.

Boom Mode “A”

Load Radius (ft)	Loaded Boom Angle (Deg.)	35.5 Ft.		45 Ft.		
		360°	Over Front	Loaded Boom Angle (Deg.)	360°	Over Front
10	68.5	120,000	120,000	73.5	87,200	87,200
12	65.0	106,800	106,800	71.0	87,200	87,200
15	59.5	90,800	90,800	66.5	82,500	82,500
20	49.5	71,400	71,400	59.5	67,400	67,400
25	37.5	55,800	56,300	51.5	55,100	55,600
30	20.0	38,700	40,500	43.0	38,300	40,500
35				32.0	28,300	32,700
40				15.5	21,800	25,200
Min. Boom Angle/Cap.	0°	20,900	20,900	0°	14,000	14,000
Load Radius (ft)	Loaded Boom Angle (Deg.)	55 Ft.		60.3 Ft.		
		360°	Over Front	Loaded Boom Angle (Deg.)	360°	Over Front
10	77.0	79,700	79,700			
12	75.0	72,400	72,400	76.5	61,400	61,400
15	71.5	63,500	63,500	73.5	57,600	57,600
20	66.0	52,300	52,300	68.5	47,100	47,100
25	60.0	44,200	44,200	63.0	39,500	39,500
30	53.5	37,800	38,000	57.5	33,900	33,900
35	47.0	27,900	32,300	51.5	27,700	29,700
40	39.0	21,500	24,900	45.0	21,400	24,800
45	29.0	17,000	19,700	37.5	16,800	19,600
50	14.5	13,500	15,800	28.5	13,400	15,800
55				15.0	10,800	12,800
Min. Boom Angle/Cap.	0°	9,000	9,000	0°	7,100	7,100

Rated Lifting Capacities In Pounds On Fully Extended Outriggers. See Set Up Note 2.

Boom Mode “B”

Load Radius (ft)	Loaded Boom Angle (Deg.)	35.5 Ft.		45 Ft.		55 Ft.			
		360°	Over Front	Loaded Boom Angle (Deg.)	360°	Over Front	Loaded Boom Angle (Deg.)	360°	Over Front
10	68.5	120,000	120,000	73.0	42,000	42,000	76.5	42,000	42,000
12	65.0	106,800	106,800	70.5	42,000	42,000	74.5	42,000	42,000
15	59.5	90,800	90,800	66.5	42,000	42,000	71.5	42,000	42,000
20	49.5	71,400	71,400	59.5	42,000	42,000	66.0	42,000	42,000
25	37.5	55,800	56,300	51.5	42,000	42,000	60.0	42,000	42,000
30	20.0	38,700	40,500	43.0	39,800	40,500	53.5	40,400	40,500
35				32.0	29,800	34,200	46.5	30,400	34,800
40				15.5	23,100	26,500	38.5	23,800	27,200
45							29.0	19,100	22,000
50							14.0	15,600	18,000
Min. Boom Angle/Cap.	0°	20,900	20,900	0°	15,100	15,100	0°	10,900	10,900
Load Radius (ft)	Loaded Boom Angle (Deg.)	65 Ft.		75 Ft.		85 Ft.			
		360°	Over Front	Loaded Boom Angle (Deg.)	360°	Over Front	Loaded Boom Angle (Deg.)	360°	Over Front
12	77.0	42,000	42,000						
15	74.5	42,000	42,000	77.0	42,000	42,000			
20	70.0	42,000	42,000	73.0	42,000	42,000	75.5	36,000	36,000
25	65.5	42,000	42,000	69.0	41,700	41,700	72.0	31,500	31,500
30	60.5	40,700	40,500	65.0	37,100	37,100	68.5	28,200	28,200
35	55.0	30,700	35,100	60.5	30,900	32,500	64.5	25,400	25,400
40	49.0	24,200	27,600	56.0	24,400	27,800	61.0	23,000	23,000
45	43.0	19,500	22,300	51.0	19,700	22,600	57.0	19,900	21,100
50	35.5	16,000	18,400	46.0	16,300	18,700	52.5	16,400	18,800
55	27.0	13,300	15,400	40.0	13,600	15,600	48.0	13,700	15,800
60	13.5	11,100	12,900	33.5	11,500	13,200	43.0	11,700	13,400
65				25.0	9,700	11,300	38.0	9,900	11,500
70				12.5	8,200	9,700	31.5	8,400	9,900
75							24.0	7,200	8,500
80							12.0	6,100	7,300
Min. Boom Angle/Cap.	0°	8,000	8,000	0°	5,900	5,900	0°	4,300	4,300
Load Radius (ft)	Loaded Boom Angle (Deg.)	95 Ft.		105 Ft.		110 Ft.			
		360°	Over Front	Loaded Boom Angle (Deg.)	360°	Over Front	Loaded Boom Angle (Deg.)	360°	Over Front
20	77.5	31,800	31,800						
25	74.5	28,300	28,300	76.0	25,700	25,700	77.0	22,500	22,500
30	71.0	25,300	25,300	73.5	23,100	23,100	74.5	22,200	22,200
35	68.0	22,900	22,900	70.5	20,900	20,900	72.0	20,100	20,100
40	64.5	20,800	20,800	67.5	19,000	19,000	69.0	18,300	18,300
45	61.5	19,000	19,000	65.0	17,400	17,400	66.0	16,700	16,700
50	58.0	16,500	17,500	61.5	15,900	15,900	63.5	15,200	15,200
55	54.0	13,800	15,900	58.5	13,900	14,700	60.5	13,900	13,900
60	50.0	11,800	13,500	55.0	11,900	13,600	57.0	11,900	12,500
65	45.5	10,000	11,700	51.5	10,100	11,800	54.0	10,200	11,200
70	41.0	8,600	10,000	48.0	8,700	10,100	50.5	8,700	10,100
75	36.0	7,300	8,700	43.5	7,400	8,800	47.0	7,500	8,800
80	30.0	6,300	7,500	39.5	6,400	7,600	43.0	6,400	7,700
85	23.0	5,400	6,500	34.5	5,500	6,600	38.5	5,500	6,700
90	12.0	4,500	5,600	29.0	4,700	5,700	34.0	4,700	5,800
95				22.0	4,000	4,900	28.5	4,000	5,000
100				11.5	3,300	4,200	22.0	3,400	4,300
105							11.0	2,800	3,700
Min. Boom Angle/Cap.	0°	3,100	3,100	0°	2,100	2,100	0°	1,700	1,700



Link-Belt

CONSTRUCTION EQUIPMENT

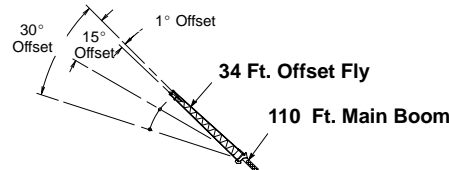
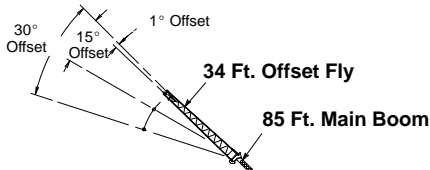

Rated Lifting Capacities In Pounds On Fully Extended Outriggers. See Set Up Note 2.

Boom Mode "B"

Load Radius (ft)	1° Offset		15° Offset		30° Offset	
	Loaded Boom Angle (Deg.)	360°	Loaded Boom Angle (Deg.)	360°	Loaded Boom Angle (Deg.)	360°
25	77.5	18,600				
30	75.0	17,000				
35	73.0	15,600	76.5	12,000		
40	70.5	14,500	74.0	11,400	77.5	9,400
45	68.0	13,600	71.5	10,800	75.0	9,100
50	65.5	12,700	69.0	10,400	72.5	8,800
55	62.5	11,900	66.5	9,900	69.5	8,400
60	60.0	11,100	63.5	9,500	67.0	8,100
65	57.0	10,300	60.5	9,100	64.0	7,800
70	54.0	9,600	58.0	8,800	61.0	7,500
75	51.0	8,600	54.5	8,400	58.0	7,300
80	47.5	7,500	51.5	8,000	54.5	7,100
85	44.0	6,600	48.0	7,000	51.0	6,900
90	40.0	5,800	44.0	6,100	47.0	6,400
95	36.0	5,100	39.5	5,400	42.5	5,600
100	31.5	4,400	35.0	4,700	37.5	4,900
105	26.0	3,900	29.5	4,100	31.5	4,200
110	19.5	3,400	22.5	3,500	23.0	3,500
Min. Boom Angle/Cap.	0°	1,800	0°	1,800	0°	1,900

Rated Lifting Capacities In Pounds On Fully Extended Outriggers. See Set Up Note 2.

Boom Mode "B"

Load Radius (ft)	1° Offset		15° Offset		30° Offset	
	Loaded Boom Angle (Deg.)	360°	Loaded Boom Angle (Deg.)	360°	Loaded Boom Angle (Deg.)	360°
35	76.5	10,500				
40	74.5	10,500				
45	72.5	10,500	76.0	9,800		
50	70.5	9,800	74.0	9,000	77.0	8,300
55	68.5	8,900	71.5	8,200	75.0	7,700
60	66.5	8,200	69.5	7,600	72.5	7,100
65	64.0	7,500	67.5	7,000	70.5	6,600
70	62.0	6,900	65.0	6,500	68.0	6,200
75	59.5	6,400	63.0	6,100	65.5	5,800
80	57.5	6,000	60.5	5,700	63.0	5,500
85	55.0	5,600	58.0	5,300	60.5	5,100
90	52.5	5,100	55.5	5,000	58.0	4,800
95	49.5	4,700	53.0	4,700	55.5	4,600
100	47.0	4,200	50.0	4,300	52.5	4,300
105	43.5	3,600	47.0	3,900	49.5	4,000
110	40.5	3,100	43.5	3,400	46.0	3,600
115	37.0	2,600	40.5	2,900	42.5	3,100
120	33.5	2,200	36.5	2,400	38.5	2,600
125	29.5	1,800	32.5	2,000	34.0	2,100
130			27.5	1,600	28.5	1,700

WARNING

Do Not Lower 34 Ft. Offset Fly In Working Position Below 26° Main Boom Angle Unless Main Boom Length Is 98 Ft. Or Less, Since Loss Of Stability Will Occur Causing A Tipping Condition.

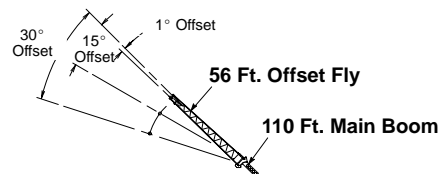
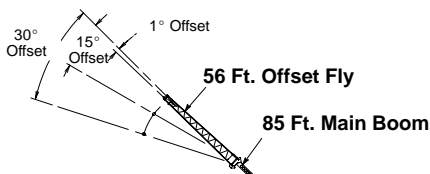

Rated Lifting Capacities In Pounds On Fully Extended Outriggers. See Set Up Note 2.

Boom Mode "B"

Load Radius (ft)	1° Offset		15° Offset		30° Offset	
	Loaded Boom Angle (Deg.)	360°	Loaded Boom Angle (Deg.)	360°	Loaded Boom Angle (Deg.)	360°
35	76.5	11,100				
40	74.5	10,500				
45	72.5	9,600	77.5	7,100		
50	70.0	8,800	75.5	6,700		
55	68.0	8,100	73.0	6,300		
60	66.0	7,600	71.0	5,900	76.0	4,800
65	63.5	7,000	69.0	5,600	74.0	4,600
70	61.5	6,600	66.5	5,300	71.5	4,500
75	59.0	6,200	64.0	5,100	69.0	4,300
80	56.5	5,800	61.5	4,800	66.5	4,100
85	54.0	5,500	59.0	4,600	64.0	4,000
90	51.5	5,200	56.5	4,400	61.5	3,900
95	49.0	4,900	54.0	4,300	58.5	3,800
100	46.0	4,700	51.0	4,100	55.5	3,700
105	43.0	4,400	48.0	3,900	52.0	3,600
110	39.5	4,000	44.5	3,800	49.0	3,500
115	36.0	3,500	41.0	3,700	45.0	3,400
120	32.0	3,100	37.0	3,300	40.5	3,400
125	27.5	2,700	32.5	2,900	35.0	3,000
130	22.0	2,300	26.5	2,500	28.0	2,500
135	14.5	2,000	18.0	2,100		
Min. Boom Angle/Cap.	0°	900	0°	900	0°	1,000

Rated Lifting Capacities In Pounds On Fully Extended Outriggers. See Set Up Note 2.

Boom Mode "B"

Load Radius (ft)	1° Offset		15° Offset		30° Offset	
	Loaded Boom Angle (Deg.)	360°	Loaded Boom Angle (Deg.)	360°	Loaded Boom Angle (Deg.)	360°
40	77.0	7,000				
45	75.5	7,000				
50	74.0	7,000				
55	72.5	7,000	77.5	6,400		
60	71.0	6,400	75.5	5,900		
65	69.0	5,900	73.5	5,400		
70	67.0	5,400	71.5	5,000	78.0°	5,000
75	65.0	5,000	70.0	4,600	74.0	4,300
80	63.0	4,600	68.0	4,300	72.0	4,000
85	61.5	4,300	66.0	4,000	70.0	3,800
90	59.5	4,000	64.0	3,700	68.0	3,500
95	57.0	3,700	61.5	3,500	66.0	3,300
100	55.0	3,500	59.5	3,300	63.5	3,100
105	53.0	3,300	57.5	3,100	61.5	2,900
110	50.5	3,100	55.0	2,900	59.0	2,800
115	48.5	2,900	53.0	2,700	56.5	2,600
120	46.0	2,600	50.5	2,600	54.0	2,500
125	43.0	2,300	47.5	2,400	51.0	2,300
130	40.5	1,900	45.0	2,200	48.0	2,100
135	37.5	1,600	42.0	1,900	45.0	1,900
140			38.5	1,500	41.5	1,700
145					37.0	1,400

WARNING

Do Not Lower 56 Ft. Offset Fly In Working Position Below 34.5° Main Boom Angle Unless Main Boom Length Is 89 Ft. Or Less, Since Loss Of Stability Will Occur Causing A Tipping Condition.

WORKING RANGE DIAGRAM

Working Range Diagram
On Tires

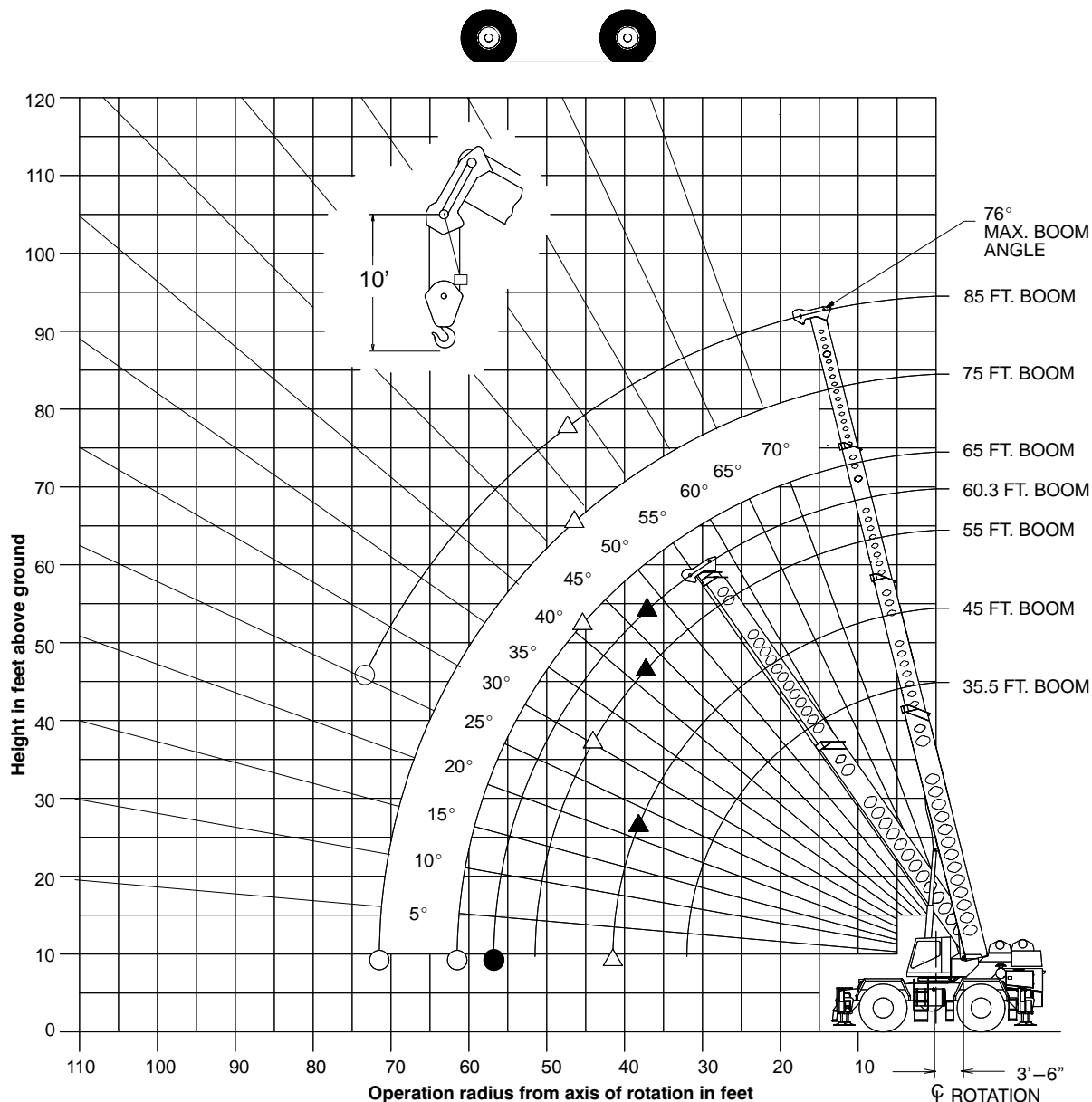

- Denotes Main Boom—Between Tire Tracks Or Centered Over Front — Boom Mode “B”
- Denotes Main Boom—Between Tire Tracks Or Centered Over Front — Boom Mode “A”
- △ Denotes Main Boom—360°—Boom Mode “B”
- ▲ Denotes Main Boom—360°—Boom Mode “A”

Note: Boom geometry shown is for unloaded condition and crane standing level on firm supporting surface. Boom deflection, subsequent radius and boom angle change must be accounted for when applying load to hook.

⚠ WARNING

Do Not Lower The Boom Below The Minimum Boom Angle For No Load As Shown In The Above Chart For The Boom Lengths Shown. Loss Of Stability Will Occur Causing A Tipping Condition. Do not exceed 76° boom angle while over side on tires to prevent tipping backwards.



Link-Belt

CONSTRUCTION EQUIPMENT

On Tire Capacities In Pounds Tire Pressure: See page 3. Stationary Capacities – Over Front – Between Tire Tracks See Operation Note 19.				
Load Radius (ft)	35.5 Ft.		45 Ft.	
	Loaded Boom Angle (Deg.)	Load	Loaded Boom Angle (Deg.)	Load
10	68.5	72,700		
12	65.0	64,400		
15	59.5	54,100	66.5	53,300
20	49.5	37,100	59.5	36,400
25	37.5	24,800	51.5	24,300
30	20.0	17,700	42.5	17,300
35			32.0	12,800
40			15.5	9,600
Min. Boom Angle/Cap.	0°	15,400	0°	8,600
Load Radius (ft)	55 Ft.		60.3 Ft.	
	Loaded Boom Angle (Deg.)	Load	Loaded Boom Angle (Deg.)	Load
20	65.5	35,800		
25	59.5	23,800	62.5	23,600
30	53.5	16,900	57.0	16,800
35	46.5	12,500	51.0	12,400
40	38.5	9,400	44.5	9,300
45	29.0	7,000	37.0	7,000
50	14.0	5,200	28.0	5,200
55			15.0	3,700
Min. Boom Angle/Cap.	0°	4,600	0°	3,100

On Tire Capacities In Pounds Tire Pressure: See Page 3. Pick & Carry (2.5 MPH) – Boom Centered Over Rear Tire Pressure: See Operation Note 19.				
Load Radius (ft)	35.5 Ft.		45 Ft.	
	Loaded Boom Angle (Deg.)	Load	Loaded Boom Angle (Deg.)	Load
10	68.5	54,700		
12	65.0	47,600		
15	59.5	39,300	66.5	38,700
20	49.5	29,800	59.0	29,300
25	37.5	23,400	51.5	22,900
30	20.0	17,700	42.5	17,300
35			32.0	12,800
40			15.5	9,600
Min. Boom Angle/Cap.	0°	15,400	0°	8,600
Load Radius (ft)	55 Ft.		60.3 Ft.	
	Loaded Boom Angle (Deg.)	Load	Loaded Boom Angle (Deg.)	Load
20	65.5	28,900		
25	59.5	22,600	62.5	22,400
30	53.5	16,900	57.0	16,800
35	46.5	12,500	51.0	12,400
40	38.5	9,400	44.5	9,300
45	29.0	7,000	37.0	7,000
50	14.0	5,200	28.0	5,200
55			15.0	3,700
Min. Boom Angle/Cap.	0°	4,600	0°	3,100

On Tire Capacities In Pounds Tire Pressure: See page 3. Stationary Capacities – Over Front – Between Tire Tracks See Operation Note 19.						
Load Radius (ft)	35.5 Ft.		45 Ft.		55 Ft.	
	Loaded Boom Angle (Deg.)	Load	Loaded Boom Angle (Deg.)	Load	Loaded Boom Angle (Deg.)	Load
10	68.5	72,700				
12	65.0	64,400				
15	59.5	54,100	66.5	42,000		
20	49.5	37,100	59.0	37,800	65.5	38,200
25	37.5	24,800	51.5	25,500	59.5	25,900
30	20.0	17,700	42.5	18,500	53.0	18,900
35			32.0	13,900	46.0	14,300
40			15.5	10,600	38.5	11,200
45					28.5	8,800
50					14.0	6,900
Min. Boom Angle/Cap.	0°	15,400	0°	9,700	0°	6,300
Load Radius (ft)	65 Ft.		75 Ft.		85 Ft.	
	Loaded Boom Angle (Deg.)	Load	Loaded Boom Angle (Deg.)	Load	Loaded Boom Angle (Deg.)	Load
25	65.0	26,100				
30	59.5	19,100	64.5	19,300		
35	54.5	14,600	60.0	14,700	64.0	14,900
40	48.5	11,400	55.5	11,600	60.5	11,700
45	42.5	9,100	50.5	9,200	56.0	9,400
50	35.5	7,200	45.5	7,400	52.0	7,600
55	26.5	5,800	39.5	6,000	47.5	6,100
60	13.0	4,500	33.0	4,800	42.5	4,900
65			25.0	3,800	37.0	4,000
70			12.0	2,900	31.0	3,100
Min. Boom Angle/Cap.	0°	4,100	0°	2,700	25.5°	

On Tire Capacities In Pounds Tire Pressure: See Page 3. Pick & Carry (2.5 MPH) – Boom Centered Over Rear Tire Pressure: See Operation Note 19.						
Load Radius (ft)	35.5 Ft.		45 Ft.		55 Ft.	
	Loaded Boom Angle (Deg.)	Load	Loaded Boom Angle (Deg.)	Load	Loaded Boom Angle (Deg.)	Load
10	68.5	54,700				
12	65.0	47,600				
15	59.5	39,300	66.5	39,300		
20	49.5	29,800	59.0	29,800	65.5	29,800
25	37.5	23,400	51.5	23,400	59.5	23,400
30	20.0	17,700	42.5	18,500	53.0	18,900
35			32.0	13,900	46.0	14,300
40			15.5	10,600	38.5	11,200
45					28.5	8,800
50					14.0	6,900
Min. Boom Angle/Cap.	0°	15,400	0°	9,700	0°	6,300
Load Radius (ft)	65 Ft.		75 Ft.		85 Ft.	
	Loaded Boom Angle (Deg.)	Load	Loaded Boom Angle (Deg.)	Load	Loaded Boom Angle (Deg.)	Load
25	65.0	23,400				
30	59.5	19,100	64.5	19,300		
35	54.5	14,600	60.0	14,700	64.0	14,900
40	48.5	11,400	55.5	11,600	60.5	11,700
45	42.5	9,100	50.5	9,200	56.0	9,400
50	35.5	7,200	45.5	7,400	52.0	7,600
55	26.5	5,800	39.5	6,000	47.5	6,100
60	13.0	4,500	33.0	4,800	42.5	4,900
65			25.0	3,800	37.0	4,000
70			12.0	2,900	31.0	3,100
Min. Boom Angle/Cap.	0°	4,100	0°	2,700	25.5°	

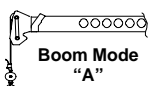
 On Tire Capacities In Pounds Tire Pressure : See Page 3. Stationary Capacities – 360 Degree See Operation Note 19.					
Load Radius (ft)	35.5 Ft.		45 Ft.		
	Loaded Boom Angle (Deg.)	Load	Loaded Boom Angle (Deg.)	Load	
10	68.5	53,000			
12	65.0	39,000			
15	59.5	26,800			
20	49.0	16,400			
25	37.5	10,700			
30	20.0	7,100	42.5	6,800	
35			31.5	4,400	
Min. Boom Angle/Cap.	0°	5,800	22.5°		
Load Radius (ft)	55 Ft.		60.3 Ft.		
	Loaded Boom Angle (Deg.)	Load	Loaded Boom Angle (Deg.)	Load	
15					
20	65.5	15,400			
25	59.5	9,900			
30	53.0	6,500			
35	46.0	4,200			
Min. Boom Angle/Cap.	42.5°		48.0°		

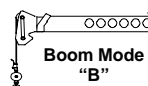
 On Tire Capacities In Pounds Tire Pressure : See Page 3. Stationary Capacities – 360 Degree See Operation Note 19.						
Load Radius (ft)	35.5 Ft.		45 Ft.		55 Ft.	
	Loaded Boom Angle (Deg.)	Load	Loaded Boom Angle (Deg.)	Load	Loaded Boom Angle (Deg.)	Load
10	68.5	53,000				
12	65.0	39,000				
15	59.5	26,800				
20	49.0	16,400				
25	37.5	10,700				
30	20.0	7,100	42.5	7,900	53.0	8,200
35			31.5	5,400	46.0	5,800
40			15.5	3,600	38.0	4,100
Min. Boom Angle/Cap.	0°	5,800	0°	3,000	30.5°	
Load Radius (ft)	65 Ft.		75 Ft.		85 Ft.	
	Loaded Boom Angle (Deg.)	Load	Loaded Boom Angle (Deg.)	Load	Loaded Boom Angle (Deg.)	Load
20						
25	64.5	12,000				
30	59.5	8,500				
35	54.0	6,100				
40	48.5	4,300				
45	42.5	3,000	50.5	3,200	56.0	3,300
Min. Boom Angle/Cap.	41.5°		48.5°		53.5°	

This page intentionally blank



This page intentionally left blank



5447-0205-E1

Bigge Crane and Rigging Co.

10700 Bigge Avenue
San Leandro, CA 94577
Phone: (888) 337-BIGGE or (510) 638-8100
Fax: (510) 639-4053
Email: info@bigge.com
Web site: www.bigge.com

Link-Belt Construction Equipment Company

Lexington, Kentucky

www.linkbelt.com

®Link-Belt is a registered trademark. Copyright 2005. We are constantly improving our products and therefore reserve the right to change designs and specifications.

