

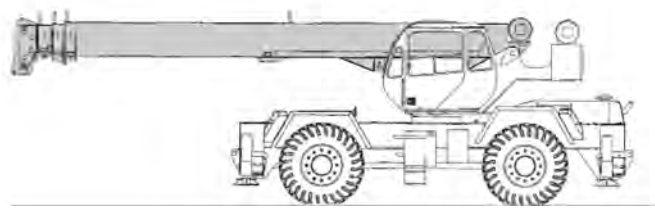

## Rough Terrain Crane Specifications | RT300-1 Series



### STANDARD BOOM EQUIPMENT

#### BOOM

30-94' (9.23-28.78 m), four section full power, mechanically synchronized boom. High-strength four plate construction with side plate holes. Anti-friction slide pads. Single boom hoist cylinder. Maximum tip height is 100' (30.48 m).

#### BOOM HEAD

Welded to fourth section of boom. Four or five load sheaves and two idler sheaves mounted on heavy duty, anti-friction bearings. Quick reeving boom head. Provisions made for side-stow jib mounting.

### OPTIONAL BOOM EQUIPMENT

#### JIBS

32' (9.68 m) side stow swing-on one-piece lattice type jib. Single sheave mounted on anti-friction bearing. Jib is offsettable at 0°, 15°, or 30°. Maximum tip height is 129' (39.32 m) with 94' (28.49 m) boom.

32-49' (9.68 -14.86 m) side-stow swing-on lattice type jib. Single sheave mounted on anti-friction bearing. Jib is extendible to 49' (14.86 m) by means of a 17' (5.18m) manual pull-out tip section, roller supported for ease of extension. Jib is offsettable at 0°, 15°, or 30°. Maximum tip height is 147' (44.81 m) with 94' (28.49 m) boom.

#### AUXILIARY BOOM HEAD

Removable auxiliary boom head has single sheave mounted on anti-friction bearing. Removable pin-type rope guard for quick reeving. Installs on main boom peak only. Removal is not required for jib use.

#### HOOK BLOCK

Three or four metallic sheaves on anti-friction bearings with hook and heavy duty hook latch.

#### HOOK AND BALL

7.0 ton (6.3 mt) top swivel ball with hook and hook latch.



# TEREX

## ROUGH TERRAIN CRANE RT300-1 SERIES

### STANDARD UPPERSTRUCTURE EQUIPMENT

#### UPPERSTRUCTURE FRAME

All welded one-piece structure fabricated with high tensile strength alloy steel. Counterweight is removable.

#### TURNTABLE CONNECTION

Swing bearing is a single row, ball type, with external teeth. The swing bearing is bolted to both the revolving upperstructure and the carrier.

#### SWING

A hydraulic motor drives a double planetary reduction gear for precise and smooth swing function. Swing speed (no load) is 2.8 rpm.

#### SWING BRAKE

Heavy duty multiple disc swing brake is mechanically actuated from operator's cab by foot pedal. Brake may be locked on or used as a momentary brake.

#### RATED CAPACITY INDICATOR

Rated Capacity Indicator with visual and audible warning system and automatic function disconnects. Second generation pictographic display includes: boom radius, boom angle, boom length, allowable load, actual load, and percentage of allowable load registered by bar graph. Operator settable alarms provided for swing angle, boom length, boom angle, tip height, and work area exclusion zone. Anti-two block system includes audio/visual warning and automatic function disconnects.

#### OPERATORS CAB

Environmental cab with all steel construction, optimized visibility, tinted safety glass throughout, and rubber floor matting is mounted on vibration absorbing pads. The cab has a sliding door on the left side, framed sliding window on the right side, hinged tinted all glass skylight and removable front windshield to provide optimized visibility of the load open or closed. Acoustical foam padding insulates against sound and weather. The deluxe six-way adjustable operator's seat is equipped with a mechanical bar suspension and includes head and arm rests.

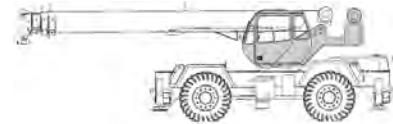

#### CONTROLS

All control levers and pedals are positioned for efficient operation. Armrest mounted dual axis controls for winch(s), swing, and boom elevation, winch rotation indication incorporated into control handles. Armrest swings up to improve access and egress. Vernier adjustable hand throttle included. Steering column mounted turn signal, wiper, and shift controls. Switches include ignition, engine stop, lights, horn, roof window wiper, hot air defroster, steering mode, parking brake, outriggers, 360° house lock. Horn and winch speed shift switches are mounted in the levers. Foot control pedals include swing brake, boom telescope, service brake and accelerator.

#### INSTRUMENTATION AND ACCESSORIES

In-cab gauges include air pressure, bubble level, engine oil pressure, fuel, engine temperature, voltmeter, transmission temperature and transmission oil pressure. Indicators include low air, high water temperature, low oil pressure, high transmission temperature and low coolant level audio/visual warning, hoist drum rotation indicator(s) and Rated Capacity Indicator. Accessories include fire extinguisher; light package including headlights, tail light, brake lights, directional signals, four-way hazard flashers, dome light and back-up lights with audible back-up alarm; windshield washer/wiper; skylight wipers; R.H. and L.H. rear view mirrors; dash lights; and seat belt. Circuit breakers protect electrical circuits.

#### HYDRAULIC CONTROL VALVES

Valves are mounted on the rear of the upperstructure and are easily accessible. Valves have electric/hydraulic operators and include one pressure compensated two spool valve for main and auxiliary witch, and one single spool valve for swing. Quick disconnects are provided for ease of installation of pressure check gauges.

#### OPTIONAL EQUIPMENT

Auxiliary Winch, Heater/Defroster, hydraulically powered Air Conditioner with or without hydraulic heater, LP or Diesel Heater/Defroster, Tachometer, Work Lights, Rotating Beacon

### STANDARD CARRIER EQUIPMENT

#### CARRIER CHASSIS

High strength chassis with four-wheel drive and four-wheel steer (4x4x4). Has box beam type construction with reinforcing cross members, a precision machined turn table mounting plate and integrally welded outrigger boxes. Decking has anti-skid surfaces, including tool storage compartment, and access steps and handles left and right side and front and rear corners.

#### AXLES AND SUSPENSION

Rear axle is a planetary drive/steer type with automatic oscillation lockouts that engage when the superstructure is swung 10° in either direction. Front axle is a planetary drive/steer type, rigid mounted to the frame for increased stability.

#### STEERING

Hydraulic four-wheel power steering for two-wheel, four-wheel, or crab steer is easily controlled by steering wheel.

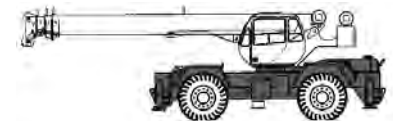

	23.5R25** tires	21.00x25 tires
Two-wheel:	36' 10.75" (11.25 m)	36' 8.7" (13.2 m)
Four-wheel:	20' 4.7" (6.22 m)	24' 7" (7.5 m)

#### TRANSMISSION

Range-shift type power-shift transmission with integral torque converter has neutral safety start, six speeds forward and six speeds reverse provides wide ration coverage. Automatic pulsating back-up alarm.





# ROUGH TERRAIN CRANE RT300-1 SERIES

## STANDARD CARRIER EQUIPMENT (CONTINUED)

### MULTI-POSITION OUT AND DOWN OUTRIGGERS

Fully independent hydraulic outriggers may be utilized fully extended to 22'(6.71 m) centerline to centerline, in their 1/2 extended position, or fully retracted for maximum flexibility. Easily removable aluminum floats, each with an area of 452 in<sup>2</sup> (2 919 cm<sup>2</sup>), stow on the outrigger boxes at their point of use. Complete controls and a sight leveling bubble are located in the operator's cab.

### WHEELS AND TIRES

Disc type wheels with full tapered bead seat rim. 150.50" (3.82 m) wheel-base.

### TIRES

23.5R25\*\* std., 21.00x25 28 PR opt.

## HYDRAULIC SYSTEM

### HYDRAULIC PUMPS

Three gear type pumps, one single and two in tandem, driven off the transmission. Combined system capability is 119 gpm (450 lpm). Includes pump disconnect.

#### Main and auxiliary winch pump

▶ 59.5 gpm (225.2 lpm) @ 3,500 psi (246.1 kg/cm<sup>2</sup>)

#### Boom Hoist and Telescope Pump

▶ 38.5 gpm (145.7 lpm) @ 3,500 psi (246.1 kg/cm<sup>2</sup>)

#### Power Steering, Outrigger and Swing Pump

▶ 21 gpm (79.5 lpm) @ 2,500 psi (175 kg/cm<sup>2</sup>)

## MAIN WINCH SPECIFICATIONS

Hydraulic winch with bent axis piston motor and planetary reduction gearing provides 2-speed operation with equal speeds for power up and down. Winch is equipped with an integral automatic brake, grooved drum, tapered flanges, standard cable roller on drum, and electronic rotation indicator.

Performance	LO-Range	HI-Range
▶ Max line speed (no load)		
▶ First layer	184 fpm (56.1 m/min)	369 fpm (112.5 m/min)
▶ Fifth layer	266 fpm (81.1 m/min)	533 fpm (162.5 m/min)
▶ Max. line pull-first layer	15,639 lb (7 094 kg)	7,298 lb (3 310 kg)
▶ Max. line pull-fifth layer	10,827 lb (4 911 kg)	5,052 lb (2 292 kg)
▶ Permissible line pull	9,000 lb (4 082 kg)	

#### Drum Dimensions

- ▶ 10.62" (270 mm) drum diameter
- ▶ 17.55" (446 mm) length
- ▶ 18.0" (457 mm) flange dia.
- ▶ Cable: 5/8" x 450' (16 mm x 137.2 m)
- ▶ Cable type: 5/8" (16 mm) 6 x 19 IWRC XIPS, right regular lay, performed.

#### Drum Capacity

- ▶ Max. Storage: 570' (173.7 m)
- ▶ 6th layer is not a working layer
- ▶ Max. useable: 455' (138.7 m)\*

\*Based on minimum flange height above top layer to comply with ANSI B30.5

## OPTIONAL AUXILIARY WINCH

Hydraulic 2-speed winch with bent axis piston motor, power up and down, equal speed, planetary reduction with integral automatic brake, grooved drum with tapered flanges, drum roller, and rotation indicator.

**Performance** (Same as main winch)

**Drum Dimensions and Capacity** (Same as main winch)

## SERVICE BRAKES

Split system air over hydraulic brakes on all four wheels, 18" diameter disc single caliper brakes on front and rear axle.

## PARKING BRAKE

Front axle equipped with spring-set, air released emergency/parking brake.

## OPTIONAL EQUIPMENT

Immersion Heater, Pintle Hook(s), Clearance Lights, Independent Rear Steering, Four Mode Rear Wheel Steer, 20,000 lb line pull front mounted winch.

## FILTRATION

Full flow oil filtration system with bypass protection includes a removable 60 mesh (250 micron) suction screen-type filter and 5 micron replaceable return line filter.

## HYDRAULIC RESERVOIR

All steel, welded construction with internal baffles and diffuser. Provides easy access to filters and is equipped with an external sight level gauge. The hydraulic tank is pressurized to aid in keeping out contaminants and in reducing potential pump cavitation. Capacity is 114 gal (432 liters). Hydraulic oil cooler is standard.

## OPTIONAL HOIST LINE

**Main winch and optional auxiliary winch**-5/8' (16mm) rotation resistant compacted strand 18 x 19 or 19 x 19.  
Min. breaking strength 22.6 tons (20.6 mt).

## ENGINE SPECIFICATIONS

Make and Model	Cummins QSB5.9 (155 hp)
▶ Type	6 cylinder
▶ Bore and Stroke	4.02 x 4.72" (102x120 mm)
▶ Displacement	360 cubic inches (5.91)
▶ Rated HP	155 hp (116 kw) @ 2500 rpm
▶ Maximum HP	160 hp (119 kw) @ 2300 rpm
▶ Rated Torque	440 lb•ft (597 N•m) @ 1500 rpm
▶ Aspiration	turbocharged
▶ Air Filter	dry type
▶ Electrical System	12 volt
▶ Alternator	100 amp
▶ Battery	(2) 12V-1600 CCA
▶ Fuel Capacity	50 gal (189 L)

## PERFORMANCE

Transmission Gear	Forward Drive	Max. Speed	Max. Tractive Effort	Grade-ability @ Stall*
▶ 1	4-wheel	1.5 mph 2.4 km/h	78,999 lb 35 800 kg	240%
▶ 2	4-wheel	3.3 mph 5.3 km/h	38,900 lb 17 237 kg	66.8%
▶ 3	4-wheel	9.0 mph 14.5 km/h	13,900 lb 6 309 kg	19.4%
▶ 4	2-wheel	4.6 mph 7.4 km/h	27,165 lb 12 322 kg	42.5%
▶ 5	2-wheel	9.5 mph 15.3 km/h	13,029 lb 5 910 kg	18%
▶ 6	2-wheel	24.5 mph 39.4 km/h	4,768 lb 2 163 kg	5.2%

\*All performance data is based on a gross vehicle weight of 81,000 lb (36 741 kg), 23.5x25 tires, 4x4 drive. Performance may vary due to engine performance. Gradeability data is theoretical and is limited by tire slip, machine stability, or oil pan design.





**GENERAL DIMENSIONS**

- Dimensions given assume the boom is fully retracted in travel position and 23.5R25 tires. Add 3.0" (76 mm) for 21.00x25 tires.
- Minimum ground clearance under:
  - transmission-21.62" (549 mm)
  - axle bowls-18.65" (474 mm)
- Approach and departure angles:
 

	23.5R25	21.00x25
Approach angle (A):	22°	26°
Departure angle (B):	18°	21°

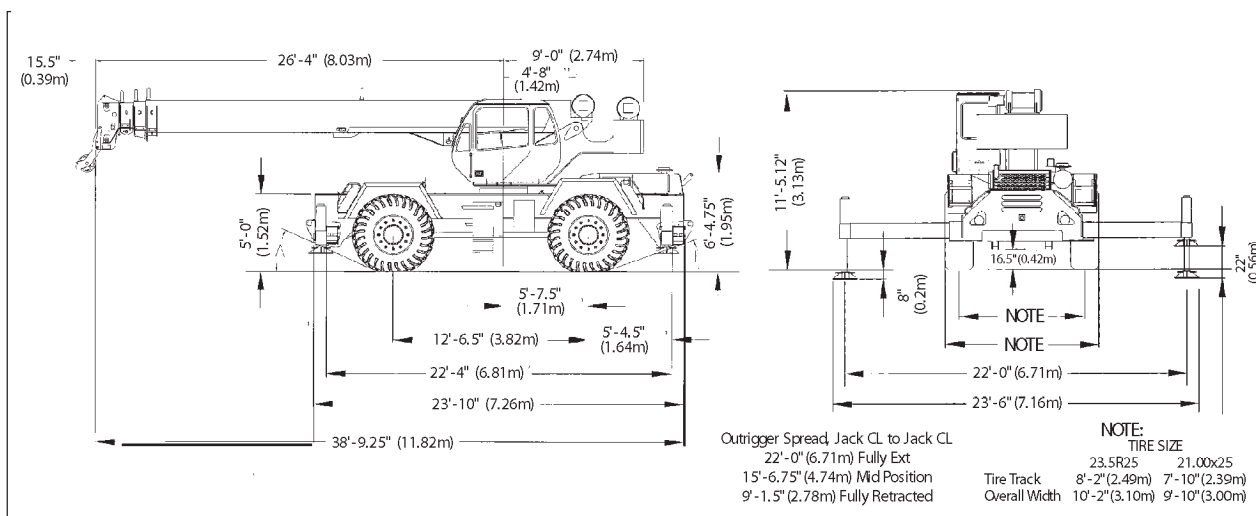

WEIGHTS & AXLE LOADS	GROSS WEIGHT LB	UPPER FACING FRONT		GROSS WEIGHT KG	UPPER FACING FRONT	
		FRONT	REAR		FRONT	REAR
Basic Crane with 10,000 lb (4536 kg) Counterweight	63,260	30,388	32,872	28 694	13 784	14 910
Add Options:						
32' (9.68 m) Swing-on jib (Stowed)	+ 1,368	+ 1,814	- 446	+ 621	+ 823	- 202
32'-49' (9.68 -14.86 m) Swing-on Jib (Stowed)	+ 1,789	+ 2,147	- 358	+ 811	+ 974	- 163
Auxiliary Boom Head	+ 100	+ 260	- 160	+ 45	+ 118	- 73
Auxiliary Winch Controls and Plumbing Only	+ 75	+ 0	+ 75	+ 34	+ 0	+ 34
Auxiliary Winch with Wire Rope, Controls, Etc.	+ 264	- 56	+ 320	+ 120	- 25	+ 145
40T (36.3 mt) 4-Sheave Hook Block	+ 690	+ 1,017	- 327	+ 313	+ 461	- 148
30T (27.2 mt) 3-Sheave Hook Block	+ 670	+ 987	- 317	+ 304	+ 448	- 144
25T (22.7 mt) 2-Sheave Hook Block	+ 682	+ 1,005	- 323	+ 309	+ 456	- 147
7T Hook and Ball (In tool box)	+ 240	+ 261	- 21	+ 109	+ 118	- 9
Pintle Hook: Front	+ 45	+ 64	- 19	+ 20	+ 29	- 9
Rear	+ 45	- 22	+ 67	+ 20	- 10	+ 30
Substitute:						
450' (137.2 m) of 18x19 class spin resistant	+ 60	- 39	+ 99	+ 27	+ 18	+ 45

Note:Weights are forTerex supplied equipment and are subject to 2% variation due to manufacturing tolerances.

**Bigge Crane and Rigging Co.**

10700 Bigge Avenue  
 San Leandro, CA 94577  
 Phone: (888) 337-BIGGE or (510) 638-8100  
 Fax: (510) 639-4053  
 Email: info@bigge.com  
 Web site: www.bigge.com

