

TR

ROUGH TERRAIN CRANE

TR-200M

JAPANESE SPECIFICATIONS

OUTLINE	SPEC. NO.
4-section Boom, 1-stage Jib	TR-200M-2-00102

Control No. JA-02

TR-200M-Z-00102

TR-200M

CRANE SPECIFICATIONS

CRANE CAPACITY

8.35m Boom	20,000kg	at 3.5m	(7 part-line)
14.3m Boom	16,000kg	at 3.5m	(6 part-line)
20.25m Boom	9,000kg	at 6.0m	(4 part-line)
26.2m Boom	6,800kg	at 7.0m	(4 part-line)
7.0m Jib	3,000kg	at 72°	(1 part-line)
Single top	3,000kg		(1 part-line)

MAX. LIFTING HEIGHT

Boom	26.5m
Jib	34.0m

MAX. WORKING RADIUS

Boom	24.0m
Jib	27.5m

BOOM LENGTH

8.35m – 26.2m

BOOM EXTENSION

17.85m

BOOM EXTENSION SPEED

17.85m / 76s

JIB LENGTH

7.0m

MAIN WINCH SINGLE LINE SPEED

High range:	103m/min	(4th layer)
Low range:	51.5m/min	(4th layer)

MAIN WINCH HOOK SPEED

High range:	14.7m/min	(7 part-line)
Low range:	7.3m/min	(7 part-line)

AUXILIARY WINCH SINGLE LINE SPEED

88m/min (2th layer)

AUXILIARY WINCH HOOK SPEED

88m/min (1 part-line)

BOOM ELEVATION ANGLE

0° – 80°

BOOM ELEVATION SPEED

0° – 80° / 40s

SWING ANGLE

360° continue

SWING SPEED

3.0rpm

WIRE ROPE

Main Winch

16mm × 150m (Diameter×Length)
 7×7+6×Fi(29) Class B ordinary · Z twist
 Spin-resistant wire rope
 Breaking strength 17.6t

Auxiliary Winch

16mm × 75m (Diameter×Length)
 7×7+6×Fi(29) Class B ordinary · Z twist
 Spin-resistant wire rope
 Breaking strength 17.6t

BOOM

4-section hydraulically telescoping boom of box construction.

(stage 2: sequential; stages 3, 4: synchronized)

BOOM EXTENSION

2 double-acting hydraulic cylinder
 1 wire rope type telescoping device

JIB

1-staged swingaround boom extension which stores alongside boom base section.
 Offset (10°)

SINGLE TOP

Single sheave. Mounted to main boom head for single line work.

HOIST

Driven by hydraulic motor and via spur gear speed reducer.
 Power load lowering / free-fall lowering type
 2 single winches

BOOM ELEVATION

1 double-acting hydraulic cylinders

SWING

Hydraulic motor driven planetary gear reducer
 Swing bearing
 Swing free/lock changeover type
 Hand brake

OUTRIGGERS

Fully hydraulic X-type (floats mounted integrally)
 Slides and jacks each provided with independent operation device.

Full extended width 5.7m

Middle extended width 3.6m

MAX. OUTRIGGER LOAD

21.4t

HYDRAULIC PUMPS

3 gear pumps

HYDRAULIC OIL TANK CAPACITY

370 liters

SAFETY DEVICES

Automatic moment limiter (AML-U)
 Over-winding cutout
 Level gauge
 Hook safety latch
 Winch drum lock
 Hydraulic safety valve
 Telescopic counterbalance valve
 Elevation counterbalance valve
 Jack pilot check valve
 Swing lock

EQUIPMENTS

Crane cab heater (with defroster)
 Reclining seat (with headrest)

CARRIER SPECIFICATIONS

ENGINE

Model HINO EL100
 Type 4-cycle, 6-cylinder, direct-injection, water-cooled diesel engine
 Piston displacement 7,862cc
 Max. output 165PS at 2,800rpm
 Max. torque 49kg·m at 1,600rpm

TORQUE CONVERTER

4-element, 1-stage unit

TRANSMISSION

Power shift type (wet multi-plate clutch)
 3 forward and 1 reverse speeds

REDUCER

Axle dual-ratio reduction

DRIVE

2-wheel drive (4×2) / 4-wheel drive (4×4) selection

FRONT AXLE

Full floating type

REAR AXLE

Full floating type (with no-spin differential)

SUSPENSION

Front Parallel leaf spring type
 Rear Parallel leaf spring type

STEERING

Fully hydraulic power steering

BRAKE SYSTEM

Service Brake

Hydraulic brake with pneumatic power device.
 Internal expanding leading and trailing type

Parking Brake

Mechanically operated, internal expanding duo-servo shoe type acting on drum at transmission case rear.

FRAME

Welded box-shaped structure

ELECTRIC SYSTEM

24 V DC. 2 batteries of 12V (120Ah)

FUEL TANK CAPACITY

250 liters

CAB

Two-man type

TIRES

Front 14.00-24-20PR (OR)
 Rear 14.00-24-20PR (OR)

SAFETY DEVICES

Emergency steering device
 Spring lock device

GENERAL DATA

DIMENSIONS

Overall length	10,450mm
Overall width	2,490mm
Overall height	3,420mm
Wheel base	3,000mm
Tread Front	2,060mm
Rear	2,060mm

WEIGHTS

Gross vehicle weight	
Total	22,710kg
Front	11,355kg
Rear	11,355kg

PERFORMANCE

Max. traveling speed	40km/h
Gradeability (tan θ)	0.6
Min. turning radius	4.9m (4-wheel steering) 8.3m (2-wheel steering)



TOTAL RATED LOADS

(1) With outriggers set (360°)

Unit : ton

Outriggers fully extended							Outriggers middle extended							
B (m)	A	8.35 m	14.3 m	20.25m	26.2m	E (°)	C	7.0 m	B (m)	A	8.35 m	14.3 m	20.25m	26.2 m
	3.0	20.0	16.0								80		3.0	3.0
3.5	20.0	16.0	9.0			75		3.0	3.5	15.0	16.0	9.0		
4.0	18.5	15.5	9.0			72		3.0	4.0	13.0	13.5	9.0		
4.5	16.5	14.2	9.0	6.8		70		2.8	4.5	11.0	11.0	9.0	6.8	
5.0	15.0	13.1	9.0	6.8		65		2.4	5.0	9.0	9.0	9.0	6.8	
5.5	13.7	12.1	9.0	6.8		60		2.0	5.5	7.7	7.55	8.0	6.8	
6.0	12.5	11.2	9.0	6.8		55		1.65	6.0	6.6	6.4	6.8	6.8	
6.5	11.5	10.4	8.5	6.8		50		1.3	6.5	5.7	5.5	5.9	6.2	
7.0		9.7	8.0	6.8		45		1.0	7.0		4.8	5.2	5.4	
8.0		7.8	7.1	6.1		40		0.8	8.0		3.7	4.1	4.3	
9.0		6.2	6.3	5.5		35		0.65	9.0		2.9	3.3	3.5	
10.0		5.0	5.4	4.9		30		0.5	10.0		2.3	2.7	2.9	
11.0		4.15	4.6	4.4					11.0		1.85	2.2	2.45	
12.0		3.5	3.9	4.0					12.0		1.5	1.85	2.1	
13.0			3.35	3.55					13.0			1.55	1.75	
14.0			2.9	3.1					14.0			1.3	1.5	
15.0			2.55	2.7					15.0			1.05	1.25	
16.0			2.2	2.4					16.0			0.9	1.05	
17.0			1.95	2.1					17.0			0.7	0.9	
18.0			1.7	1.85					18.0			0.5	0.7	
19.0				1.65					19.0				0.6	
20.0				1.45										
22.0				1.15										
24.0				0.9										

A = Boom length B = Working radius C = Jib length
E = Boom angle

NOTES:

1. The total rated loads shown are for the case when the outriggers are set horizontally on firm ground. The values above the bold lines are based on the crane strength while those below are based on the crane stability.
2. The weights of the slings and hooks (main winch hook: 230kg, auxiliary winch hook: 50kg) are included in the total rated loads shown.
3. The total rated load is based on the actual working radius including the deflection of the boom.
4. The number of part lines for each boom length should not exceed the values below. The load per line should not exceed 2.9t for the main winch and 3.0t for the auxiliary winch.

A	8.35 m	14.3 m	20.25 m	26.2 m	J
H	7	6	4	4	1

A = Boom length H = No. of part-line J = Jib / Single top

5. The total rated loads for free-fall operations is 1/5 of the total rated loads given above. The load per line in this case should not exceed 0.6t for both the main winch and the auxiliary winch.
6. Do not use the jib with the "Outriggers middle extended".
7. The total rated load for the single top shall be the value obtained by subtracting 150kg from the total rated load of the main boom and must not exceed 3.0t.

(2) Without outriggers

Unit : ton

B (m)	Stationary						Creep (travelling at 1.6km/h or less)					
	8.35 m BOOM		14.3 m BOOM		20.25 m BOOM		8.35 m BOOM		14.3 m BOOM		20.25 m BOOM	
	F	G	F	G	F	G	F	G	F	G	F	G
3.0	12.0	8.0	8.5	7.0			8.5	6.0	6.5	4.8		
3.5	10.5	7.1	8.5	7.0	6.0	4.5	7.7	5.0	6.5	4.8	5.0	3.2
4.0	9.4	5.8	8.5	5.5	6.0	4.5	6.9	4.3	6.5	4.1	5.0	3.2
4.5	8.4	4.7	7.8	4.4	6.0	4.5	6.2	3.6	6.0	3.4	5.0	3.2
5.0	7.6	3.9	7.0	3.6	6.0	4.0	5.55	3.0	5.3	2.8	5.0	3.2
5.5	6.6	3.2	6.2	3.05	5.5	3.4	5.0	2.5	4.75	2.3	4.7	2.7
6.0	5.8	2.7	5.4	2.55	5.1	2.9	4.5	2.05	4.3	1.9	4.3	2.3
6.5	5.0	2.3	4.65	2.15	4.65	2.5	4.0	1.7	3.9	1.6	3.9	2.0
7.0			4.1	1.8	4.3	2.15			3.5	1.35	3.6	1.7
8.0			3.2	1.3	3.55	1.6			2.7	0.95	3.0	1.25
9.0			2.55	0.9	2.9	1.2			2.1	0.6	2.4	0.9
10.0			2.05	0.55	2.4	0.9			1.65		1.95	0.7
11.0			1.6		2.0	0.65			1.3		1.6	
12.0			1.25		1.6				1.0		1.3	
13.0					1.3						1.05	
14.0					1.1						0.9	
15.0					0.9						0.7	
16.0					0.75						0.55	
17.0					0.6							

B = Working radius F = Front G = 360°

NOTES:

1. The total rated loads shown are for the case when the crane is set horizontally on firm ground. The values above the bold lines are based on the crane strength while those below are based on the crane stability. The foundation, working conditions, etc. should be taken into consideration adequately when using the crane for actual work. (Tire air pressure: 8.0kg/cm²).
2. The weights of the slings and hooks (main winch hook: 230kg) are included in the total rated loads shown.
3. The total rated loads are based on the actual working radii into which are included the deflections of the boom and the tires.
4. The number of part lines for each boom length should not exceed the values below. The load per line should not exceed 2.9t (for the main winch).

A	8.35 m	14.3 m	20.25 m
H	7	6	4

A = Boom length
H = No. of part-line

5. Free-fall operations should not be performed without outriggers.
6. The 26.2m boom, the jib and the single top should not be used without the outriggers.
7. The boom must be kept inside a 2° area (1° each to the left and right) over front of the carrier when performing "Over front" crane operations without the outriggers.

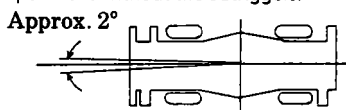

8. When creeping while hoisting a load, the swing brake should be applied, the load should be kept as close to the ground as possible but not touching the ground and the speed should be kept at 1.6km/h or less. In particular, any abrupt steering, starting or braking must be avoided.
9. Crane operations should not be performed when creeping while hoisting a load.

TR-200M-2-00102

WORKING RADIUS - LIFTING HEIGHT

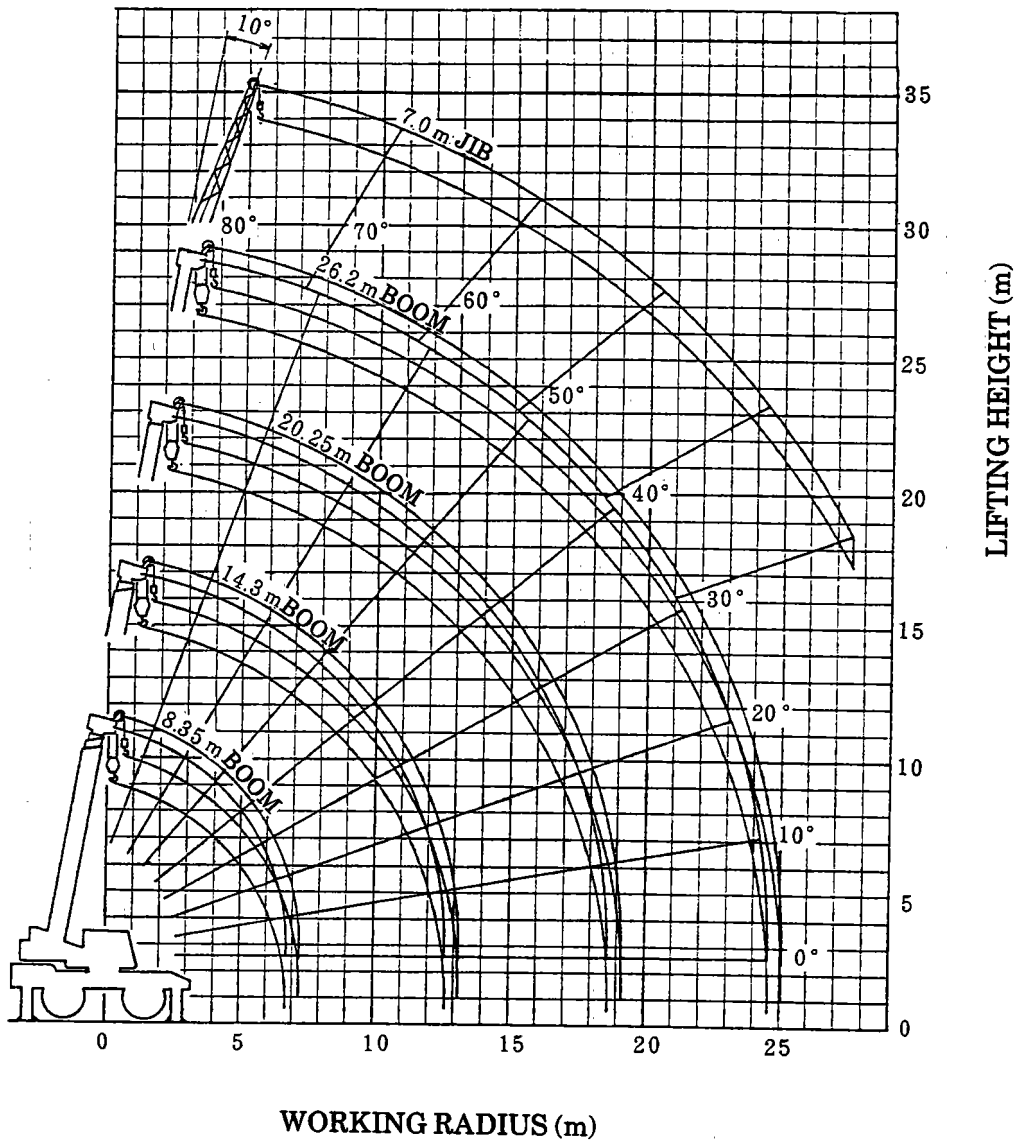

NOTES:

1. The deflection of the boom is not incorporated in the figure above.
2. The figure above is for the case when the outriggers are fully extended (360°).

DIMENSIONS (1/100)

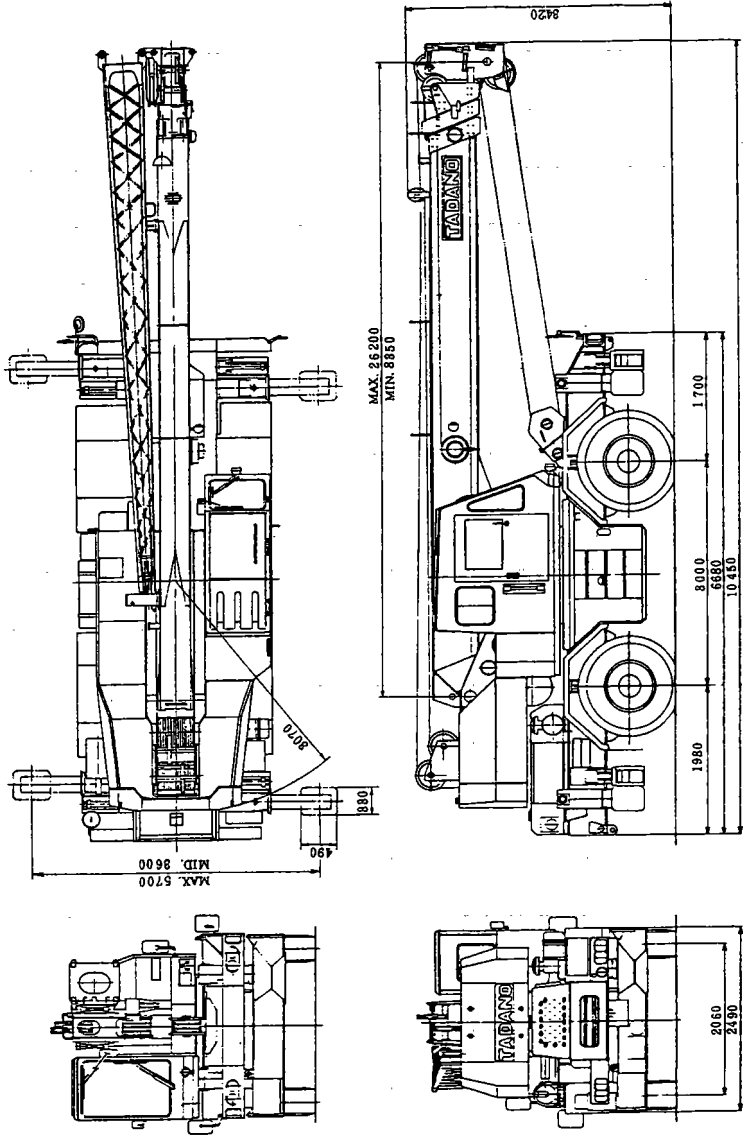

◆ MEMO ◆

Lined area for writing a memo, consisting of multiple horizontal dashed lines.



TR

ROUGH TERRAIN CRANE

TR-200M**Optional Jib*****JAPANESE SPECIFICATIONS***

These specifications are for the optional jib for the TR-200M type crane.
Refer to these specifications along with specification sheet no. TR-200M-2-00102.

Control No. TR-200M-2-TJ-01

TR-200M-2-TJ

TR-200M

CRANE SPECIFICATIONS

Optional Jib

JIB

1-staged swingaround boom extension which stores alongside boom base section.
Dual offset (10°, 30°) type.
With jib extending device

BOOM LENGTH

7.0m

MAXIMUM TOTAL RATED LOAD

3,000kg (1 part-line)

MAX. LIFTING HEIGHT

34.0m

MAX. WORKING RADIUS

27.8m

TOTAL RATED LOADS

Optional Jib

Unit : ton

Outriggers fully extended (360°)		
E (°) \ D	10°	30°
80	3.0	2.0
75	3.0	2.0
73	3.0	2.0
70	2.75	2.0
65	2.35	1.85
60	2.0	1.7
55	1.65	1.45
50	1.25	1.15
45	0.95	0.9
40	0.75	0.7
35	0.6	0.5
30	0.45	0.4

D = Jib offset E = Boom angle

NOTES:

1. The total rated loads shown are for the case when the outriggers are set horizontally on firm ground. The values above the bold lines are based on the crane strength while those below are based on the crane stability.
2. The weights of the slings and hooks (auxiliary winch: 50kg) are included in the total rated loads shown.
3. The number of part lines for the hook is 1.
4. The total rated loads for free-fall operations is 1/5 of the total rated loads given above.

WORKING RADIUS - LIFTING HEIGHT

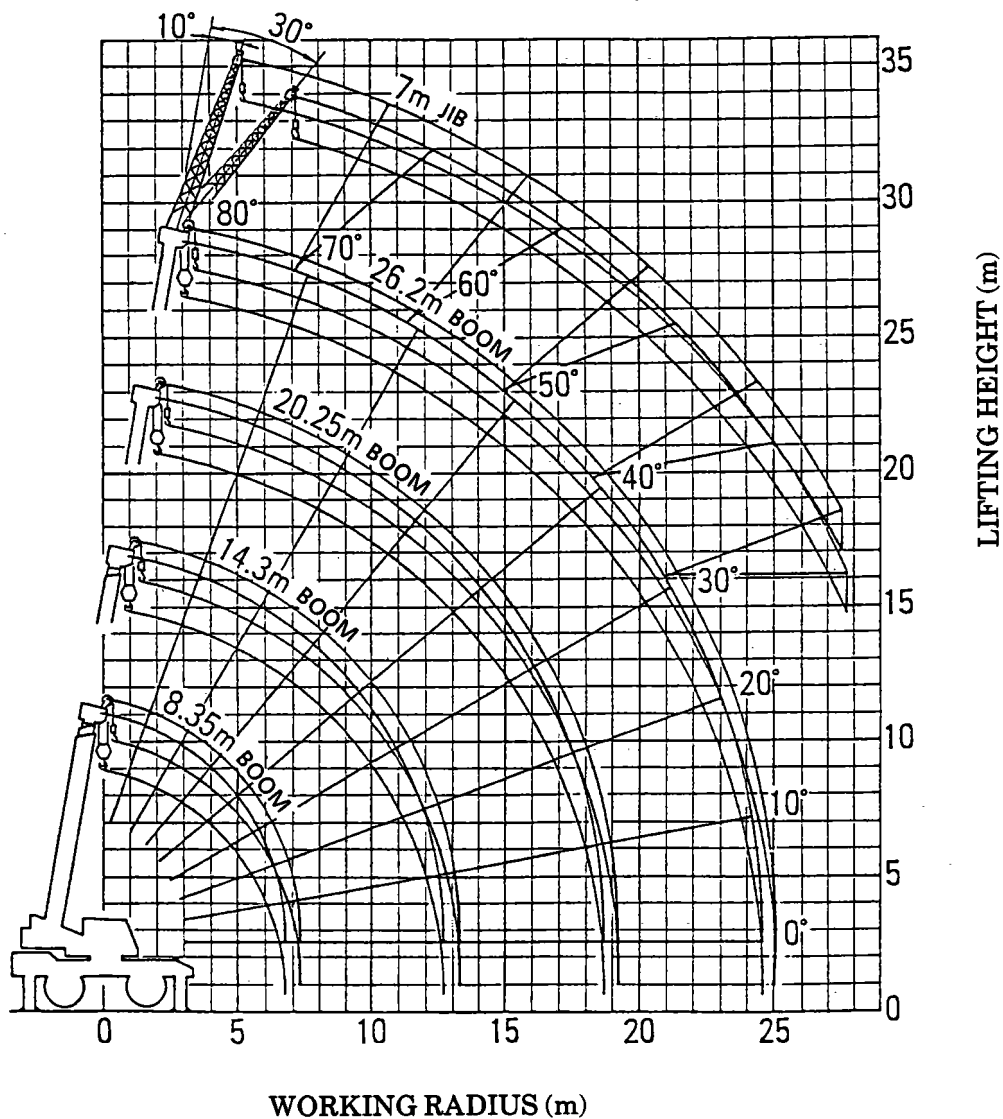

NOTES:

1. The deflection of the boom is not incorporated in the figure above.
2. The figure above is for the case when the outriggers are fully extended (360°).

◆ **MEMO** ◆

Lined area for writing a memo, consisting of multiple horizontal dashed lines.

