

Heavy-Duty - Module Type THP/SL 6

Main Features

- Module longitudinally and laterally combinable
- Box-section center beam with integrated air and hydraulic fluid reservoirs
- Front and rear optimized bolt-plate-coupling for longitudinal combinations
- 2 dual tired pendular axles with a total of 8 tires per axle line
- Wheelsets mounted to the frame by ball bearing race rings
- All wheelsets equipped with hydraulic suspension stroke $\pm 11^{13}/16$ " hydro-pneumatic gas accumulator suspension and hose rupture safety valves
- Hydro-mechanical 2-circuit all-wheel force-steering integrated into the bogie, with maximum wheelset steering angle of $\pm 55^\circ$, including counter-steering
- 2-line all-wheel air service brake and spring-loaded parking brake

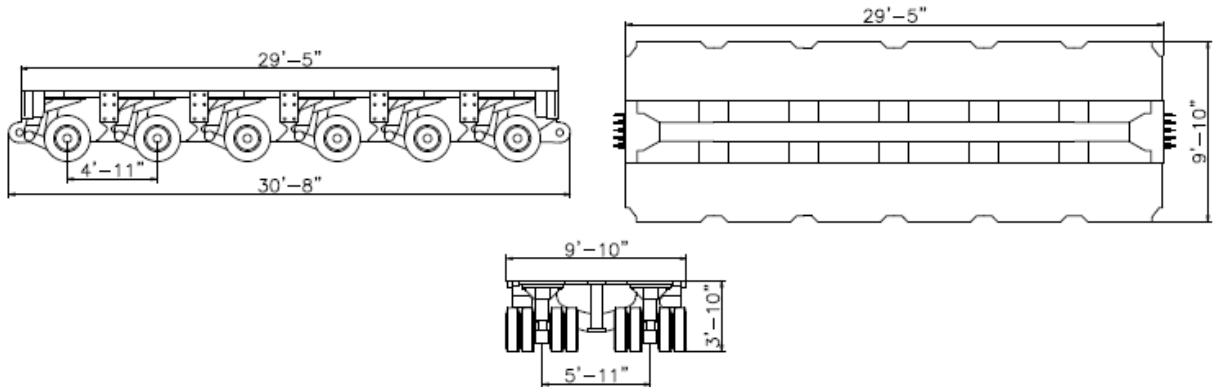

Technical Data

| Speed | | 3 mph | 30 mph | 50 mph |
|-----------------------------------|---------|---------------|-------------|-------------|
| Technical axle load per axle line | | 74,960 lbs | 40,570 lbs | 36,160 lbs |
| Deadweight (without accessories) | approx. | 43,650 lbs | 43,650 lbs | 43,650 lbs |
| Maximum payload | approx. | 406,110 lbs | 199,770 lbs | 173,310 lbs |
| Tires | | 215/75 R 17.5 | | |

* For reference only. Contact your Bigge representative for additional information.