



Provisional Specifications

GS-300XL

30 Ton Capacity (27.2 Metric Tons)

HYDRAULIC TRUCK CRANE

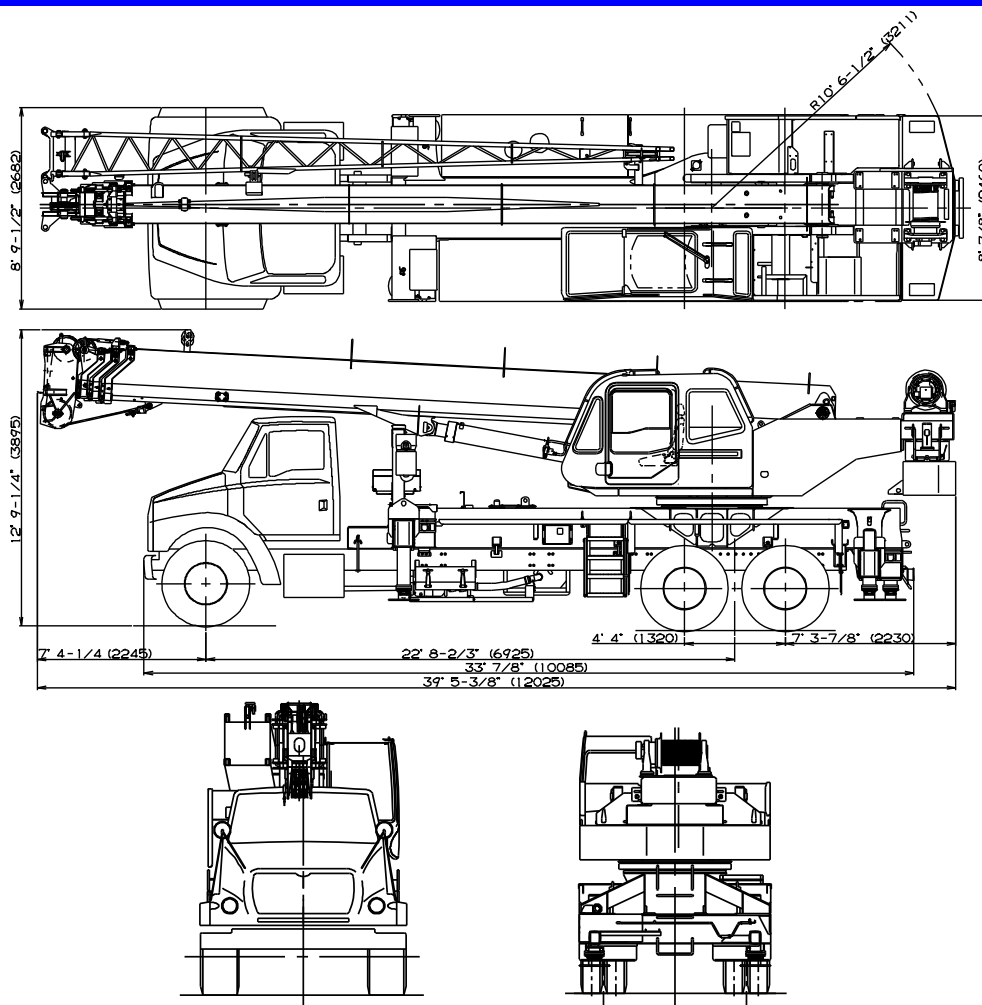

GENERAL DIMENSIONS

	Feet	Meters
Turning radius		
Front tire (curb to curb)	50.9'	15.5
Tail swing of counterweight	10' 6 1/2"	3.21

TRAVELING

Max. traveling speed 80.8mph (130km/h)

Specifications are subject to change without notice.

CRANE SPECIFICATIONS

BOOM

Four section full power synchronized telescoping boom, 32.8'-105.6' (10.0m-32.2m), of round hexagonal box construction with 4 sheaves, 13-1/4" (0.336m) pitch diameter, at boom head. The synchronization system consists of two-telescope cylinders, an extension cable and retraction cable. Hydraulic cylinder fitted with holding valve. Boom telescope sections are supported by wear pads both vertically and horizontally.

BOOM ELEVATION - By a double acting hydraulic cylinder with holding valve. Elevation -2.5°-80.5°.

JIB - Lattice type, 5° or 30° offset (tilt type). Single sheave, 14-1/2"(0.368m) pitch diameter, at jib head. Stored alongside base boom section. Jib length is 26.2' (8.0m).

ANTI-TWO BLOCK - Pendant type over-winding cut out device with audio-visual (FAILURE lamp/BUZZER) warning system.

SWING

Hydraulic axial piston motor driven through planetary swing speed reducer. Continuous 360° full circle swing on ball bearing turntable at 2.8rpm. Equipped with manually locked/released swing brake. Twin swing System: Free swing or lock swing controlled by selector switch on right hand of side console.

HOIST

MAIN HOIST - Variable speed type with grooved drum driven by hydraulic axial piston motor through winch speed reducer. Power load lowering and raising. Equipped with automatic brake (neutral brake) and counterbalance valve. Controlled independently of auxiliary hoist. Equipped with cable follower and drum rotation indicator.

DRUM - Grooved 12-5/8"(0.32m) root diameter x 19-1/16" (0.4845m) wide. Wire rope: 574' of 5/8" diameter rope (175m of 16mm). Drum capacity: 720' (219.5m) 6 layers. Maximum line pull (available): 14,200lbs. (6,430kg). Maximum line speed: 410FPM (125m/min).

HOOK BLOCKS

20 ton (18.1 metric ton) - 3 sheaves with swivel hook and safety latch, for 5/8"(16mm) wire rope. (OPTIONAL)
3.74 ton (3.4 metric ton) - Weighted hook with swivel and safety latch, for 5/8"(16mm) wire rope.

HYDRAULIC SYSTEM

PUMPS - Two variable piston pumps for crane functions. Tandem gear pump for swing and outriggers. Powered by carrier engine. Pump disconnect for crane is engaged/ disengaged by rocker switch from carrier cab.

CONTROL VALVES - Multiple valves actuated by pilot pressure with integral pressure relief valves.

RESERVOIR - 92 gallon (350 lit.) capacity. External sight level gauge.

FILTRATION - 10 micron return filter, full flow with bypass protection, located inside of hydraulic reservoir. Accessible for easy replacement.

OIL COOLER - Air cooled fan type.

COUNTERWEIGHT

Pinned to superstructure frame 1,980lbs.(900kg).
Removable from superstructure frame 3,970lbs. (1,800kg).

CAB AND CONTROLS

Left side, 1 man type, steel construction with sliding door access and safety glass windows opening at side. Door window is powered control. Windshield glass window and roof glass window are shatter-resistant. Adjustable control lever stands for swing, boom hoist, boom telescoping and main hoist. Control lever stands can change neutral positions and tilt for easy access into cab. Engine throttle knob. Foot operated controls: boom hoist, boom telescoping and engine throttle. Hot water cab heater and air conditioning (OPTIONAL).

Dash-mounted engine stop, monitor lamps, cigarette lighter, front washer and wiper switch, power window switch, swing brake switch, free swing / lock swing selector switch and ashtray.

Instruments - Hydraulic oil pressure is monitored and displayed on the AML-L display panel.

Tadano electronic LOAD MOMENT INDICATOR system (AML-L) including:

- Control lever lockout function
- Load radius / boom angle / tip height / swing range preset function
- Warning buzzer
- Boom angle / boom length / jib offset angle / load radius / rated lifting capacities / actual loads read out
- Ratio of actual load moment to rated load moment indication
- Automatic Speed Reduction and Soft Stop function on boom elevation and swing (swing range restricted only) 2222
- Working condition register switch
- External warning lamp

TADANO AML-L monitors outrigger extended length and automatically programs the corresponding "RATED LIFTING CAPACITIES" table.

2nd boom emergency / 3rd, top boom emergency telescoping switch. Correct jib status select switch. Upper console includes working light switch, roof washer and wiper switch, air conditioning control switch. Swing lock lever and 3 way adjustable seat with high back.

NOTE: Each crane motion speed is based on unladen conditions.

HOISTING PERFORMANCE

Layer	Main hoist - 12-5/8" (0.32m) drum, 5/8" (16mm) wire rope							
	Line speeds ²		Line pulls				Drum grooved lagging	
			Available ¹		Permissible ⁴		Total wire rope	
	F.P.M	m/min	Lbs.	kgf	Lbs.	kgf	Feet	Meters
1st	285	87	14,200	6,430	12,600	5,710	98.8	30.1
2nd	311	95	13,000	5,890	11,500	5,210	206.4	62.9
3rd	334	102	12,000	5,430	10,500	4,760	322.2	98.2
4th	360	110	11,100	5,040	9,700	4,400	446.2	136.0
5th	383	117	10,400	4,700	9,000	4,080	579.1	176.5
6th ³	410	125	9,700	4,400	8,400	3,800	720.1	219.5

¹ Developed by machinery with each layer of wire rope, but not based on rope strength or other limitation in machinery or equipment.

² Line speeds based only on hook block, not loaded.

³ Sixth layer of wire rope is not recommended for hoisting operations.

⁴ Permissible line pull may be affected by wire rope strength.

DRUM DIMENSIONS

	Inch	mm
Root diameter	12-5/8"	320
Length	Main 19-1/16"	484
Flange diameter	20-7/8"	530



CARRIER SPECIFICATIONS

MANUFACTURER - STERLING TRUCKS

MODEL - LT7501

TYPE - Left hand steering, 6x4

FRAME - High tensile steel.

TRANSMISSION - 10 forward and 3 reverse speeds.

TRAVEL SPEEDS -

Gear step/Gear	Traveling speeds in mph / k.p.h
1 st gear	0-4.1(0-6.6)
2 nd gear	6.4(10.3)
3 rd gear	9.6(15.4)
4 th gear	13.0(20.9)
5 th gear	17.6(28.3)
6 th gear	23.8(38.3)
7 th gear	32.9(52.9)
8 th gear	44.1(71.0)
9 th gear	60.3(97.0)
10 th gear	80.8(130.0)
1 st Revers gear	0-4.3(6.9)
2 nd Revers gear	6.7(10.8)
3 rd Revers gear	27.2(43.7)

AXLES - Front: Full floating type, steering axle

Rear: Full floating type, driving axle with inter-wheel differential lock.

ENGINE (US EPA on High way)

Model	CUM ISC-300
No. of cylinders	6
Combustion	4 cycle, turbo charged and inter cooled
BoreXStroke, in.(mm)	4.49' X 5.31' (114X135)
Displacement, cu. in (liters)	506 (8.3)
Air cleaner	Dry type, replaceable element
Oil filter	Full flow and bypass with replaceable element
Fuel filter	Spin-on type
Fuel tank, gal.(liters)	70 (265), left side of carrier

STEERING - Dual-circuit hydraulic and mechanical steering
Tilt steering wheel

SUSPENSION - Front and Rear: Leaf springs. (Dana Spicer)

BRAKE SYSTEMS - Service: Full air brakes on all wheels.
ABS system.

TIRES - Front: 425/65R22.5 SingleX2 Rear: 11R22.5 Dual x 4

OUTRIGGERS - Four hydraulic, beam and jack outriggers. Vertical jack cylinders equipped with integral holding valve. Each outrigger beam and jack is controlled independently from either side of carrier. Beams extend to 20' 1/8" (6.1 m) center-line and retract to within 8' 5" (2.48 m) overall width. Controls and sight bubble located on both side of carrier. Two outrigger extension lengths are provided with corresponding "RATED LIFTING CAPACITIES" for crane duty in confined areas

Mid. extension 13' 1-1/2"(4.0m) center to center
Max. extension 20' 1/8"(6.1m) center to center

Float size(Diameter) 1' 3-1/2" (0.4m)



STANDARD EQUIPMENT

FOR SUPERSTRUCTURE

- Four section full power synchronized boom 32.8'~105.6' (10.0 m~32.2 m)
- 26.2' (8.0m) lattice jib (tilt type) with 5° or 30° pinned offsets.
- Main hoist with grooved drum, cable follower and 574' of 5/8" cable.
- Drum rotation indicator main hoist.
- Anti-Two block device (overwind cutout)
- Tadano electronic load moment indicator system (AML-L) including
 - Control lever lockout function
 - Load radius / boom angle / tip height / swing range preset function
 - Warning buzzer
 - Boom angle / boom length / jib offset angle / load radius / rated lifting capacities / actual loads read out
 - Automatic Speed Reduction and Soft Stop function on boom elevation and/or swing.
 - Ratio of actual load moment to rated load moment indication
 - Working condition register switch
 - External warning lamp
- Outrigger extension length detector
- Tadano twin swing system
- Self centering finger control levers with pilot control
- Control pedals for boom hoist and boom telescoping
- 3 way adjustable cloth seat with armrests, high back and seat belt
- Tinted safety glass
- Front windshield wiper and washer
- Roof window wiper and washer
- Power window (Door of the cab)
- Cab floor mat
- Cigarette lighter
- Electric fan in cab
- 3.74 ton (3.4 metric ton) hook with swivel
- Weighted hook storage compartment
- Hydraulic oil cooler
- 4,000lbs removable counterweight
- 3 working lights
- 4,000lbs removable counterweight

FOR CARRIER

- Cummins ISC-300 turbo charged and inter cooled engine.
- Front tires 425/65R22.5
- Rear tires 11R22.5
- Anti-block system (ABS)
- Air dryer
- Windshield wiper and washer
- 3 point type seat belt
- Sun visor
- Tilt steering wheel
- Air suspension seat
- Tachometer
- Hourmeter
- Engine temperature indicator
- Fuel level indicator
- Speedometer
- Reversing signal (Back-up alarm)
- High-beam light
- Hazard warning system
- Electric horn
- Hot water cab heater with defroster
- FM/AM radio
- Hot water cab heater and air conditioner (Upper cab)
- Electric fan in cab

OPTIONAL EQUIPMENT

- 20 ton (18.1) metric ton) - 3 sheaves hook block



GS-300XL WORKING RANGE CHART

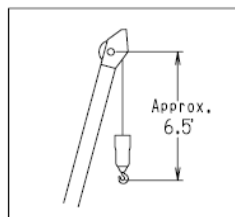
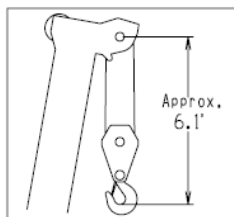
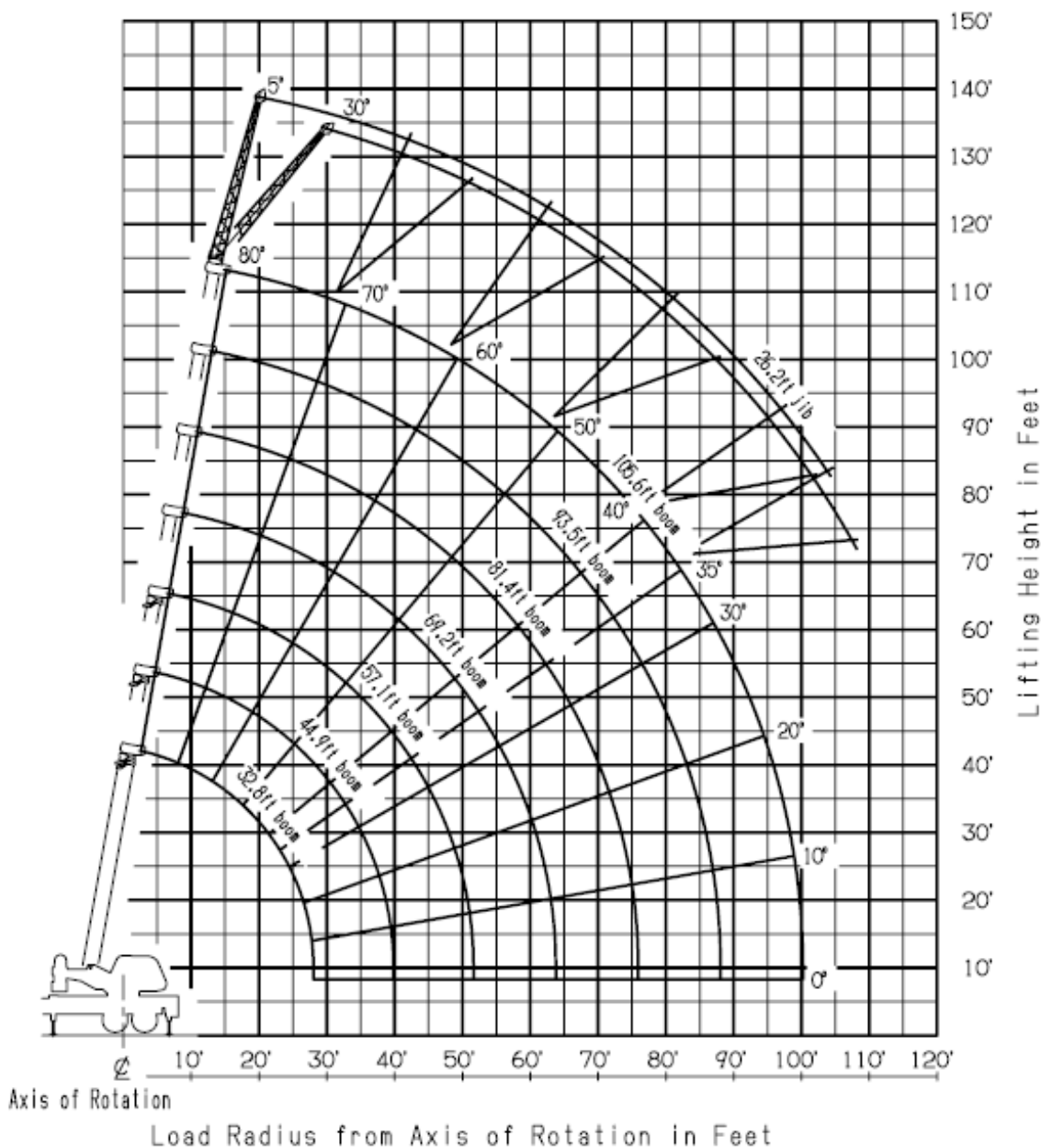

NOTE: Boom and jib geometry shown are for unloaded condition and machine standing level on firm supporting surface. Boom deflection and subsequent radius and boom angle change must be accounted for when applying load to hook.

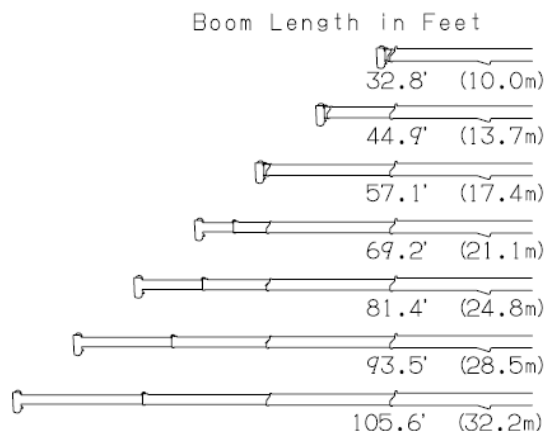

GS-300XL RATED LIFTING CAPACITIES (IN POUNDS)

ON OUTRIGGERS FULLY EXTENDED 20' 1/8" (6.1m) SPREAD, 4,000LBS COUNTERWEIGHT, 360° ROTATION														
Boom Length in Feet														
A	32.8		44.9		57.1		69.2		81.4		93.5		105.6	
	B	(10.0m)	B	(13.7m)	B	(17.4m)	B	(21.1m)	B	(24.8m)	B	(28.5m)	B	(32.2m)
8	70.3	60,000	76.3	38,600	79.5	32,200								
10	66.5	60,000	73.6	38,600	77.5	32,200								
12	62.6	56,000	71.0	38,600	75.5	32,200	78.2	20,900						
15	56.3	48,500	67.0	38,600	72.5	32,200	75.7	20,900	77.9	17,900				
20	44.2	37,100	59.7	36,800	67.0	29,900	71.5	20,900	74.6	17,900	77.2	16,100	79.0	14,300
25	28.3	28,500	51.5	28,000	61.3	24,500	67.1	19,500	71.0	17,200	74.4	15,500	76.4	13,000
30			42.2	19,300	55.1	18,800	62.6	16,600	67.3	14,500	71.1	13,100	73.6	11,200
35			30.4	13,700	48.3	13,300	57.6	14,200	63.3	12,500	67.8	11,200	70.7	9,830
40			7.5	10,200	40.8	9,830	52.4	10,700	59.3	11,000	64.4	9,810	67.8	8,730
45					31.8	7,430	46.6	8,250	54.9	8,710	60.9	8,620	64.8	7,830
50					18.9	5,670	39.2	6,480	50.3	6,920	57.1	7,250	61.6	7,030
55							32.6	5,090	45.2	5,560	53.2	5,860	58.4	6,080
60							23.0	4,010	39.7	4,480	49.0	4,780	55.0	5,000
65									33.4	3,620	44.5	3,900	51.3	4,120
70									25.7	2,890	39.5	3,200	47.5	3,400
75									14.3	2,290	34.0	2,580	43.4	2,800
80											27.4	2,070	39.0	2,270
85											19.1	1,630	34.2	1,830
90													28.5	1,460
95													21.6	1,120
C	0°													

LIFTING CAPACITIES AT ZERO DEGREE BOOM ANGLE ON OUTRIGGERS FULLY EXTENDED 20' 1/8" (6.1m) SPREAD, 4,000LBS COUNTERWEIGHT, 360° ROTATION														
Boom Length in feet														
B	32.8		44.9		57.1		69.2		81.4		93.5		105.6	
	A	(10.0m)	A	(13.7m)	A	(17.4m)	A	(21.1m)	A	(24.8m)	A	(28.5m)	A	(32.2m)
0	28.1	22,500	40.1	10,100	52.3	5,000	64.3	2,800	76.6	2,000	88.6	1,100	100	400

D	105.6' (32.2m) Boom + 26.2' (8.0m) Jib			
	5° Tilt		30° Tilt	
	R	W	R	W
80	24.6	6,610	34.5	4,190
77.5	30.9	6,400	40.3	4,000
75	37.0	6,170	45.9	3,860
72.5	43.1	6,000	51.5	3,700
70	48.8	5,840	56.8	3,530
67.5	54.0	5,300	61.9	3,400
65	59.1	4,720	66.7	3,310
62.5	64.1	4,300	71.5	3,200
60	68.8	3,860	76.0	3,090
57.5	73.5	3,400	80.3	2,800
55	77.9	2,950	84.4	2,600
52.5	82.1	2,500	88.3	2,200
50	86.0	2,070	91.8	1,850
47.5	90.2	1,700	95.4	1,600
45	93.7	1,410	98.8	1,300
42.5	97.5	1,200	102.0	1,100
40	101.0	950	105.0	860
37.5	104.0	800	108.0	700
35	108.0	570	111.0	530

NOTE :The lifting capacity data stored in the LOAD MOMENT INDICATOR (AML-L) is based on the standard number of parts of line listed in the chart.

- A** :Load radius in feet
- B** :Boom angle in degree
- C** :Minimum boom angle in degree for indicated length (no load)
- D** :Boom angle in degree
- R** :Load radius in feet
- W** :Rated lifting capacity in pounds

Boom Length in Feet (meters)	32.8 (10.0m)	32.8 to 57.1 (10.0m to 17.4m)	57.1 to 105.6 (17.4m to 32.2m)	Jib
Number of parts of line	8	6	4	1



GS-300XL RATED LIFTING CAPACITIES (IN POUNDS)

ON OUTRIGGERS FULLY EXTENDED 13' 1-1/2" (4.0m) SPREAD, 4,000LBS COUNTERWEIGHT, 360° ROTATION														
Boom length in feet														
A	32.8		44.9		57.1		69.2		81.4		93.5		105.6	
	B	(10.0m)	B	(13.7m)	B	(17.4m)	B	(21.1m)	B	(24.8m)	B	(28.5m)	B	(32.2m)
8	70.4	60,000	76.2	38,600	79.5	32,200								
10	66.6	60,000	73.7	38,600	77.5	32,200								
12	62.5	56,000	71.0	38,600	75.5	32,200	78.1	20,900						
15	56.2	34,600	66.9	33,800	72.5	32,200	75.7	20,900	78.0	17,900				
20	44.4	19,600	59.4	19,100	66.8	18,700	71.4	19,600	74.6	17,900	77.2	16,100	79.0	14,300
25	28.3	12,900	51.3	12,400	61.0	12,000	66.9	12,900	70.7	13,400	74.1	13,700	76.4	13,000
30			41.9	8,530	54.9	8,200	62.1	9,020	66.9	9,480	70.8	9,810	73.4	10,000
35			30.5	6,020	48.3	5,710	57.2	6,480	62.9	6,940	67.3	7,250	70.3	7,470
40			7.6	4,250	40.9	3,970	51.9	4,720	58.8	5,160	63.8	5,490	67.4	5,710
45					32.1	2,670	46.2	3,400	54.4	3,840	60.2	4,140	64.2	4,390
50					19.1	1,700	39.8	2,380	49.9	2,820	56.4	3,130	61.0	3,350
55							32.4	1,590	44.8	2,030	52.6	2,310	57.8	2,540
60									39.3	1,370	48.4	1,680	54.3	1,870
65											43.8	1,120	50.7	1,340
C	0°						34°			40°		48°		

LIFTING CAPACITIES AT ZERO DEGREE BOOM ANGLE ON OUTRIGGERS FULLY EXTENDED 13' 1-1/2" (4.0m) SPREAD, 4,000LBS COUNTERWEIGHT, 360° ROTATION								
Boom length in feet								
B	32.8		44.9		57.1		69.2	
	A	(10.0m)	A	(13.7m)	A	(17.4m)	A	(21.1m)
0	28.1	9,500	40.1	4,200	52.3	1,200	64.4	300

D	105.6' (32.2m) Boom + 26.2' (8.0m) Jib			
	5° Tilt		30° Tilt	
	R	W	R	W
80	24.6	6,610	34.4	4,190
77.5	30.8	6,400	40.2	4,000
75	37.0	6,170	45.9	3,860
72.5	42.6	5,300	51.6	3,700
70	47.8	4,430	56.5	3,510
67.5	52.8	3,400	61.2	2,700
65	57.5	2,580	65.6	2,120
62.5	62.3	2,000	69.9	1,600
60	67.0	1,410	74.1	1,190
57.5	71.4	1,000	78.5	800
55	75.5	620	82.6	510

NOTE :The lifting capacity data stored in the LOAD MOMENT INDICATOR (AML-L) is based on the standard number of parts of line listed in the chart.

- A** :Load radius in feet
- B** :Boom angle in degree
- C** :Minimum boom angle in degree for indicated length (no load)
- D** :Boom angle in degree
- R** :Load radius in feet
- W** :Rated lifting capacity in pounds

Boom Length in Feet (meters)	32.8 (10.0m)	32.8 to 57.1 (10.0m to 17.4m)	57.1 to 105.6 (17.4m to 32.2m)	Jib
Number of parts of line	8	6	4	1



GS-300XL RATED LIFTING CAPACITIES (IN POUNDS)

ON OUTRIGGERS FULLY EXTENDED 6' 9-7/8" (2.08m) SPREAD,
4,000LBS COUNTERWEIGHT, 360° ROTATION

Boom length in feet		
A	32.8	
	B	(10.0m)
8	70.3	39,700
10	66.5	26,100
12	62.5	18,800
15	55.9	12,600
20	44.2	7,160
25	28.1	4,250
C	0°	

LIFTING CAPACITIES AT ZERO DEGREE BOOM ANGLE ON OUTRIGGERS FULLY EXTENDED
6' 9-7/8" (2.08m) SPREAD, 4,000LBS COUNTERWEIGHT, 360° ROTATION

Boom length in feet		
B	32.8	
	A	(10.0m)
0	28.1	2,700

NOTE :The lifting capacity data stored in the LOAD MOMENT INDICATOR (AML-L) is based on the standard number of parts of line listed in the chart.

- A** :Load radius in feet
- B** :Boom angle in degree
- C** :Minimum boom angle in degree for indicated length (no load)

Boom Length in Feet (meters)	32.8 (10.0m)	Jib
Number of parts of line	8	1



WARNING AND OPERATING INSTRUCTIONS FOR LIFTING CAPACITIES

GENERAL

1. RATED LIFTING CAPACITIES apply only to the machine a originally manufactured and normally equipped by TADANO LTD.

Modifications to the machine or use of optional equipment other than that specified can result in a reduction of capacity

2. Construction equipment can be hazardous if improperly operated or maintained. Operation and maintenance of this machine must be in compliance with information in the operation, safety and maintenance manual supplied with machine. If these manuals are missing, order replacements through the distributor
3. The operator and other personnel associated with this machine shall fully acquaint themselves with the latest American National Standards Institute (ANSI) safety standards for cranes.

SET UP

1. Rated lifting capacities on the chart are the maximum allowable crane capacities and are based on the machine standing level on firm supporting surface under ideal job conditions. Depending on the nature of the supporting surface, it may be necessary to have structural supports under the outrigger floats to spread the loads to a larger bearing surface.
2. For outrigger operation, outriggers shall be properly extended with tires free of supporting surface before operating crane

OPERATION

1. Rated lifting capacities have been tested to and meet minimum requirements of SAE J1063-Cantilevered Boom Crane Structures Method of Test.
2. Rated lifting capacities do not exceed 85% of the tipping load on outriggers fully extended as determined by SAE J765-Crane Stability Test Code.
Rated lifting capacities for partially extended outriggers are determined from the formula, Rated Lifting Capacities = (Tipping Load - 0.1 x Tip Reaction)/1.25
3. Rated lifting capacities above bold lines in the chart are based on crane strength and those below, on its stability. They are based on actual load radius increased by boom deflection.
4. The weight of handling device such as hook blocks, slings etc., must be considered as part of the load and must be deducted from the lifting capacities
5. Rated lifting capacities are based on freely suspended loads and make no allowance for such factors as the effect of wind sudden stopping of loads, supporting surface conditions operating speeds, side loads, etc. Side pull on boom or jib is extremely dangerous.
6. Rated lifting capacities do not account for wind on lifted load or boom. Rated lifting capacities and boom length shall be appropriately reduced, when wind velocity is above 20 mph (9 m/sec.).
7. Rated lifting capacities at load radius shall not be exceeded. Do not tip the crane to determine allowable loads
8. Do not operate at boom lengths, radii, or boom angle, where no capacities are shown. Crane may overturn without any load on the hook.
9. When boom length is between values listed, refer to the rated lifting capacities of the next longer and next shorter booms for the same radius. The lesser of the two rated lifting capacities shall be used.

10. When making lifts at a load radius not shown, use the next longer radius to determine allowable capacity
11. Load per line should not exceed 8,820 lbs. (4,000kg) for main winch and auxiliary winch
12. Check the actual number of parts of line with LOAD MOMENT INDICATOR (AML-L) before operation. Maximum lifting capacity is restricted by the number of parts of line of LOAD MOMENT INDICATOR (AML-L). Limited capacity is as determined from the formula, Single line pull for main winch (8,820 lbs.) x number of parts of line
13. The boom angle before loading should be greater to account for deflection. For rated lifting capacities, the loaded boom angle and the load radius is for reference only
14. The 32.8' (10.0m) boom length capacities are based on boom fully retracted. If not fully retracted [less than 44.9' (13.7m) boom length], use the rated lifting capacities for the 44.9' (13.7m) boom length.
15. Extension or retraction of the boom with loads may be attempted within the limits of the RATED LIFTING CAPACITIES. The ability to telescope loads is limited by hydraulic pressure boom angle, boom length, crane maintenance, etc
16. When base jib or top jib or both jib removing, jib state switch select removed.
17. When erecting and stowing jib, be sure to retain it by hand or by other means to prevent its free movement.
18. Use "ANTI-TWO BLOCK" disable switch when erecting and stowing jib and when stowing hook block. While the switch is pushed, the hoist does not stop, even when overwind condition occurs.
19. For boom length with 26.2' (8.0m) jib, rated lifting capacities are determined by loaded boom angle only in the column headed "105.6' (32.2m) boom + 26.2' (8.0m) jib".
For angles not shown, use the next lower loaded boom angle to determine allowable capacity.

DEFINITIONS

1. Load Radius: Horizontal distance from a projection of the axis of rotation to supporting surface before loading to the center of the vertical hoist line or tackle with load applied
2. Loaded Boom Angle: The angle between the boom base section and the horizontal, after lifting the rated lifting capacity at the load radius.
3. Working Area: Area measured in a circular arc about the centerline of rotation.
4. Freely Suspended Load: Load hanging free with no direct external force applied except by the hoist line
5. Side Load: Horizontal side force applied to the lifted load either on the ground or in the air



WARNING AND OPERATING INSTRUCTIONS FOR USING THE LOAD MOMENT INDICATOR (AML-L)

1. When operating crane on outriggers:
 - Set Starter switch to "ON" .
 - Press the outrigger mode select key to register for the outrigger operation. Press the set key, then the outrigger mode indicative symbol changes from flickering to lighting.
 - Press the boom mode select key to register the boom mode, then the boom mode indicative symbol changes from lighting to flickering. Each time the boom mode select key is pressed, the mode changes. Press the set key to select the status that corresponds to the actual state of the boom, then the boom mode indicative symbol changes from flickering to lighting.
 - When erecting and stowing jib, select the status of jib set (jib state indicative symbol flicker).
2. This machine is equipped with an automatic swing stopping device. (For the details, see Operation Maintenance Manual.) But, operate very carefully because the automatic swing stop does not work in the following cases.
 - When the "AML Emergency" switch is set to "OVERRIDE" and the "OVERRIDE" key switch outside the cab is on.
3. During crane operation, make sure that the displays on front panel are in accordance with actual operating conditions.
4. The displayed values of LOAD MOMENT INDICATOR (AML-L) are based on freely suspended loads and make no allowance for such factors as the effect of wind, sudden stopping of loads, supporting surface conditions, operating speed, side loads, etc.
For safe operation, it is recommended when extending and lowering boom or swinging, lifting loads shall be appropriately reduced.
5. LOAD MOMENT INDICATOR (AML-L) is intended as an aid to the operator. Under no condition should it be relied upon to replace use of capacity charts and operating instruction. Sole reliance upon LOAD MOMENT INDICATOR (AML-L) aids in place of good operating practice can cause an accident. The operator must exercise caution to assure safety.

GS-300XL Axle weight distribution chart

	Pounds			Kilograms		
	GVW	Front	Rear	GVW	Front	Rear
Base machine with 70gal.(265L) fuel and 4,000lbs removable counterweight on carrier.	59,370	19,610	39,760	26,930	8,895	18,035
Remove:						
3.74 ton (3.4 metric ton) hook ball	-220	-130	-90	-100	-60	-40
4,000lbs removable counterweight	-3,970	-1,790	-2,180	-1,800	-810	-990

Permissible Axle Load

	Pounds			Kilograms		
	GVW	Front	Rear	GVW	Front	Rear
Permissible axle load	66,000	20,000	46,000	29,900	9,000	20,900



